

GEND-INF--021

DE82 016227

ANALYSIS DATA ON SAMPLES FROM THE TMI-2 REACTOR-
COOLANT SYSTEM AND REACTOR-COOLANT BLEED TANK

R. L. Nitschke

Published May 1982

EG&G Idaho, Inc.
Idaho Falls, Idaho 83415

DISCLAIMER

This document contains information that is the property of the United States Government. The United States Government hereby grants to the public the right to reproduce and disseminate this information for non-commercial purposes only, without charge, provided that the source is acknowledged. The United States Government does not assume any liability for the accuracy, completeness, or usefulness of the information displayed on this document. The views and opinions expressed herein are those of the author and do not necessarily reflect those of the United States Government or any agency thereof.

Prepared for the
U.S. Department of Energy
Three Mile Island Operations Office
Under Contract No. DE-AC07-76ID01570

ABSTRACT

Two liquid samples from the Three Mile Island Unit 2 (TMI-2) Reactor Coolant System (RCS) and three liquid samples from the three Reactor Coolant Bleed Tanks (RCBT) were taken during the time period March 29, 1979 to August 14, 1980. The samples were analyzed for radionuclide concentrations by two independent laboratories, Exxon Nuclear Idaho Co., Inc. (ENICO) and EG&G Idaho, Inc. at the Idaho National Engineering Laboratory (INEL). The RCS sample taken on March 29, 1979 was also analyzed by Science Applications, Inc. (SAI). This report presents the methods used and the results of these analyses.

CONTENTS

ABSTRACT	ii
INTRODUCTION	1
ANALYSES AT EXXON NUCLEAR IDAHO COMPANY, INC.	3
ANALYSES AT EG&G IDAHO, INC.	14
ANALYSES AT SCIENCE APPLICATIONS, INC.	16
DISCUSSION	22
RCS-1	22
RCS-2, RCBT-A, RCBT-B, and RCBT-C	22
RCS-1 Versus RCS-2	24
REFERENCES	25

FIGURE

1. INEL TMI-2 RCS and RCBT sample analysis flowsheet	2
--	---

TABLES

1. TMI-2 RCS and RCBT filter sample volumes: total solids and particle size distributions	5
2. TMI-2 RCS and RCBT solid sample analyses: X-ray diffraction and direct current emission spectrometry measurements	6
3. TMI-2 RCS and RCBT solid sample analysis: gamma-ray spectrometry measurements	7
4. TMI-2 RCS and RCBT solid sample analysis: beta isotopic measurements	8
5. TMI-2 RCS and RCBT solid sample analysis: alpha isotopic measurements	9
6. TMI-2 RCS and RCBT liquid sample gamma spectrometry analysis after filtration	10
7. TMI-2 RCS and RCBT liquid sample gamma spectrometry analysis before and after filtration	11
8. TMI-2 RCS and RCBT filtrate sample analysis: pH, conductivity, specific gravity, anions, and elemental	12

9.	TMI-2 RCS and RCBT filtrate analysis ^3H , ^{14}C , ^{144}Ce , ^{129}I , and alpha and beta isotopes	13
10.	TMI-2 RCS and RCBT solid sample analysis	15
11.	TMI-2 RCS-2 cesium scavenges	18
12.	TMI-2 RCS-1 concentrations of radionuclides and mass of cesium	19
13.	Comparison of the TMI-2 RCS-1 measurements	23
14.	Comparison of ENICO and EG&G Idaho measurements	23

ANALYSIS DATA ON SAMPLES FROM THE TMI-2 REACTOR COOLANT SYSTEM AND
REACTOR COOLANT BLEED TANK

INTRODUCTION

A series of chemical analyses were performed on five Three Mile Island Unit-2 liquid samples and their associated solids. Two liquid reactor coolant samples and three liquid reactor coolant bleed tank samples were taken. Of the two liquid reactor coolant samples, identified as RCS-1 and RCS-2, the first was taken March 29, 1979, the day after the accident began and the second sample was taken August 14, 1980, approximately sixteen and one-half months later. Both were drawn from the cold leg sampling line upstream of the letdown cooler. The three liquid reactor coolant bleed tank samples, identified as RCBT-A, RCBT-B, and RCBT-C, were collected from Tanks A, B, and C on December 20, 1979, January 28, 1980, and February 4, 1980, respectively. These bleed tank samples were taken prior to processing through EPICOR-II and were filtered prior to collection. The filter solids were destroyed.

All of the samples have been analyzed by two independent laboratories, Exxon Nuclear Idaho Company (ENICO),¹ and EG&G Idaho, Inc.² both at the Idaho National Engineering Laboratory (INEL). RCS-1 was also analyzed by Science Applications, Inc. (SAI).³ This report is a brief description of the analysis techniques used and the corresponding results for each of the three laboratories.

Figure 1 shows the INEL sample analysis flowsheet for the two RCS and three RCBT samples. As required, RCS-1, RCS-2, RCBT-A, RCBT-B, and RCBT-C have the respective volumes of approximately 150 ml, 150 ml, 125 ml, 150 ml, and 150 ml. There was an additional 20-ml sample of RCS-1 in a poly bottle that was split into two parts and sent to SAI for analysis.

During the review of preliminary data from ENICO,⁴ it became apparent that the RCS-2 and RCBT-A samples had been switched at some point in the sampling/handling process.⁵ The data have been appropriately changed to reflect this.

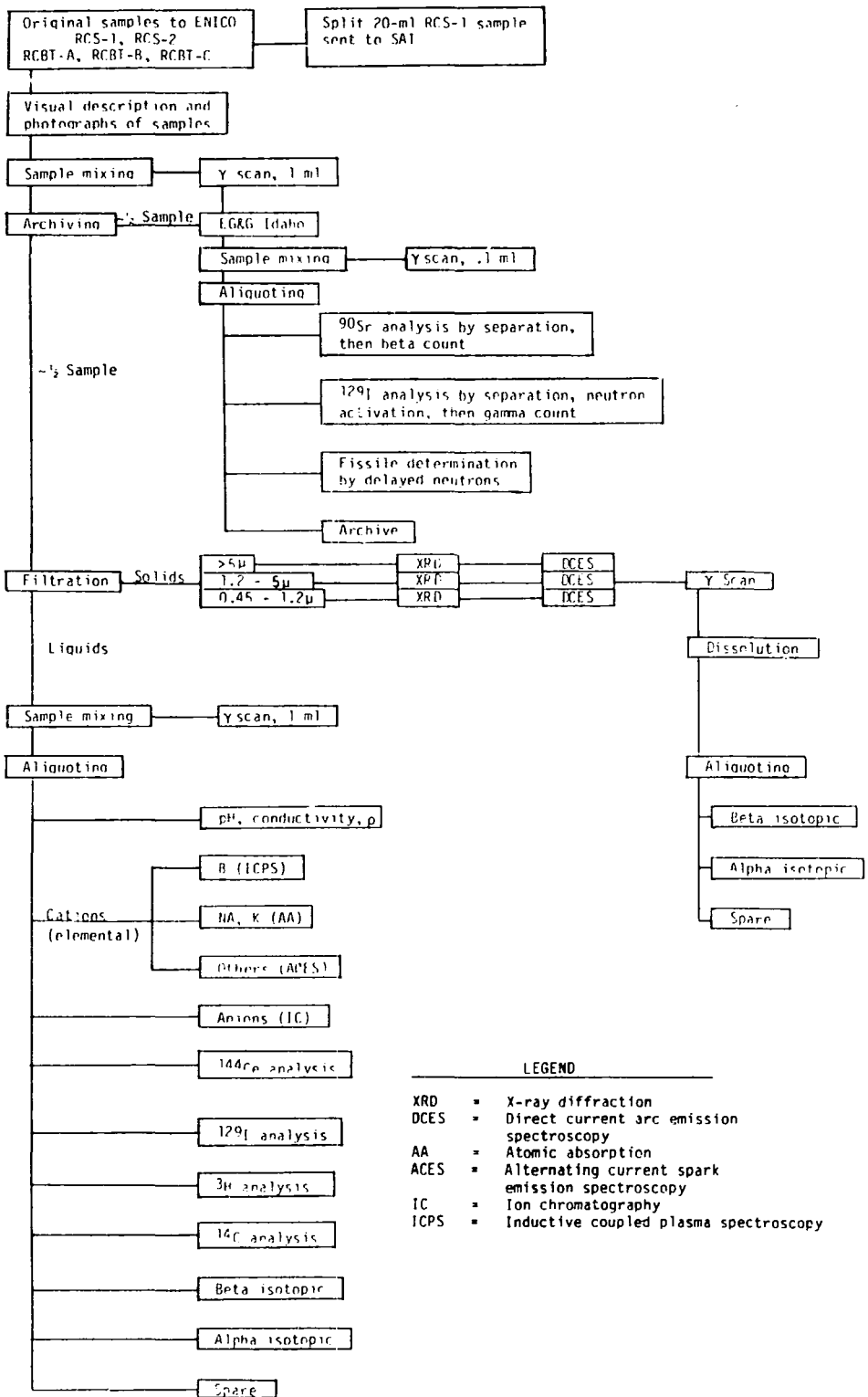

Figure 1. INEL TMI-2 RCS and RCBT sample analysis flowsheet.

On receipt of the samples, a visual description was made and photographs taken. Three samples, RCS-1, RCS-2, and RCBT-A, were slightly yellow; the other two, RCBT-B and RCBT-C, were greenish-blue. Samples RCBT-B and RCBT-C also contained suspended blackish solids. None of the samples contained visible floc or sediments.

Prior to splitting the samples for archiving, each was manually shaken and a 1.0-ml aliquot of each was assayed in a calibrated geometry using gamma-ray spectrometry. The samples were divided in approximately two halves; one half was archived, and the other half was taken for filtration and subsequent analysis. The 1.0-ml aliquots used for the gamma-ray analysis were recombined with the archived half of the samples. It should be noted that at the conclusion of the analyses the previously greenish-blue samples had turned yellow, presumably due to oxidation.

To determine the quantities of solids and to obtain a measure of the particle size distributions of the solids in the sample, each of the samples was filtered through a series of three preweighed filters. The three filters, in order of use, were a 5.0- μ Teflon filter, a 1.2- μ Millipore membrane filter, and a 0.45- μ Millipore membrane filter. After filtration, the three filters for each sample were individually weighed, the quantities of solids on each filter were calculated, and the volumes of the filtrates were measured. During filtration, each sample became progressively colorless, and the filter papers became coated with yellowish or greenish-blue solids.

Following filtration and weighing of the samples, x-ray diffraction (XRD) and direct current arc emission spectrometry (DCES) analyses were performed. The XRD and DCES analyses were performed on small aliquots of the solid material scraped from the filter and were performed only for filters containing sufficiently removable quantities of sample.

Prior to gamma-ray spectrometry analysis, the three separate filters for a given sample were combined and pelletized. The samples were then analyzed by gamma-ray spectrometry in a calibrated geometry.

The last steps in the analysis of the solids associated with the five samples included sample dissolution, aliquoting into three portions, and measurement of beta and alpha isotopic content.

For the five filtrates of the five original samples, the first steps were manual shaking and gamma-ray spectrometry analyses of 1.0-ml aliquots of each filtrate. Each 1.0-ml aliquot was recombined with its respective filtrate and each sample was divided into 10 aliquots, one of which was held in reserve. Measurements and/or analyses performed on the remaining nine aliquots included alpha and beta isotopic, ^{129}I , ^3H , ^{14}C , ^{144}Ce , anions, cations (elemental), pH, conductivity, and density.

Tables 1-5 contain the measurement data for the solids associated with the five samples from TMI Unit 2. Table 1 presents the total solids and the particle size distributions for the five samples. Table 2 lists the XRD measurements to determine the presence of crystalline compounds and the DCES measurements of the cation (elemental) content of the samples. Tables 3, 4, and 5 show results of the gamma-ray spectrometry and of the beta and alpha isotopic measurements. In all cases noted, uncertainties are at a one-sigma confidence level.

Tables 6-9 contain the measurement data for the liquid portions of the samples. Uncertainties listed in the tables are at a one-sigma confidence level. Tables 6 and 7 list the gamma spectroscopy analysis data for the samples before and after filtration. Measurement data corrected to time of sampling (T_0) have also been included for the postfiltration samples. Table 8 lists measurements of pH, conductivity, and specific gravity for the filtrate samples, and the elemental and anion measurement results. Table 9 presents the results of the ^3H , ^{14}C , ^{144}Ce , ^{129}I , and beta and alpha isotopic analyses, corrected to T_0 .

TABLE 1. TMI-2 RCS AND RCBT FILTER SAMPLE VOLUMES: TOTAL SOLIDS AND PARTICLE SIZE DISTRIBUTIONS

<u>Sample</u>	<u>Filtered Sample Volumes (ml)</u>	<u>Total Solids (mg)</u>	<u>Particle Size Distribution</u>		
			<u>>5μ (mg)</u>	<u>1.2-5μ (mg)</u>	<u>0.45-1.2μ (mg)</u>
RCS-1	63	4.3	2.1	0.9	1.3
RCS-2	74	9.5	0	1.4	8.1
RCBT-A	78	12.2	3.2	6.4	2.6
RCBT-B	78	12.3	4.7	5.0	2.6
RCBT-C	78	20.7	8.4	5.6	6.7

TABLE 2. TMI-2 RCS AND RCBT SOLID SAMPLE ANALYSES: X-RAY DIFFRACTION AND DIRECT CURRENT EMISSION SPECTROMETRY MEASUREMENTS
(M = major [$\geq 5\%$]; m = minor [$< 5\%$ $> 0.1\%$]; T = trace [$< 0.1\%$]; A = amorphous; -- = not detected)

Sample	Particle Size (μ)	XRD Analysis ^a	Elemental Analysis by Direct Current Arc Emission Spectroscopy (wt%)													
			Ag	Al	Ca	Cr	Cu	Fe	In	Mg	Mn	Na	Ni	Si	Sn	Zr
RCS-1	5	Fe ₃ O ₄ ^b	T	--	--	m	--	M	m	--	m	--	m	--	m	m
RCS-1	1.2	A	--	m	m	--	--	M	--	m	--	m	--	m	--	--
RCS-1	0.45	A	--	--	m	m	T	M	--	m	m	--	--	m	--	m
RCS-2	1.2	A	--	T	T	--	T	M	--	m	m	--	--	m	--	--
RCBT-A	5	A	--	T	--	--	--	M	--	--	m	--	--	--	--	m
RCTB-B	5	A	--	m	m	--	T	M	--	T	m	--	--	m	--	--
RCBT-B	1.2	A	--	--	--	--	--	M	--	T	--	--	--	m	--	--
RCBT-C	5	--	--	--	--	--	--	--	--	--	--	--	--	--	--	--
RCBT-C	1.2	A	--	m	--	--	--	M	--	m	--	--	--	M	--	--

a. There was insufficient sample on the other filter samples for XRD and DCES analysis.

b. In₂O₃, Ag₂O, and ZrO₂ were possibly present.

TABLE 3. TMI-2 RCS AND RCBT SOLID SAMPLE ANALYSIS: GAMMA-RAY SPECTROMETRY MEASUREMENTS
($\mu\text{Ci/ml}$ of filtered solution corrected to T_0)

<u>Sample</u>	<u>^{134}Cs</u>	<u>^{137}Cs</u>	<u>^{144}Ce</u>	<u>^{60}Co</u>	<u>^{125}Sb</u>	<u>^{106}Ru</u>	<u>^{54}Mn</u>
RCS-1	$3.32 \pm 0.03\text{E-1}$	1.212 ± 0.005	$1.834 \pm 0.005\text{E-1}$	$2.0 \pm 0.2\text{E-3}$	$2.4 \pm 0.5\text{E-2}$	$7 \pm 1\text{E-2}$	--
RCS-2	$1.08 \pm 0.03\text{E-2}$	$4.94 \pm 0.04\text{E-2}$	$5.760 \pm 0.005\text{E-2}$	$7 \pm 1\text{E-5}$	--	--	$4 \pm 1\text{E-4}$
RCBT-A	$1.10 \pm 0.08\text{E-1}$	$5.06 \pm 0.01\text{E-1}$	$1.5 \pm 0.2\text{E-2}$				
RCBT-B	$9.05 \pm 0.07\text{E-2}$	$4.52 \pm 0.02\text{E-1}$	$5.6 \pm 0.8\text{E-4}$				
RCBT-C	$1.64 \pm 0.03\text{E-2}$	$7.56 \pm 0.05\text{E-2}$	$1.47 \pm 0.03\text{E-3}$	$4.6 \pm 0.8\text{E-5}$	--	--	--

TABLE 4. TMI-2 RCS AND RCBT SOLID SAMPLE ANALYSIS: BETA ISOTOPIC MEASUREMENTS ($\mu\text{Ci/ml}$ of filtered solution corrected to T_0)

Sample	^{90}Sr	^{89}Sr	^{91}Y	^{55}Fe	^{64}Ni
RCS-1	$9.4 \pm 0.9\text{E-}3$	<10	<2E-3	$1.0 \pm 0.1\text{E-}2$	$3.1 \pm 0.3\text{E-}6$
RCS-2	$3.8 \pm 0.3\text{E-}1$	<9	<7E-5	$1.2 \pm 0.1\text{E-}3$	$8.2 \pm 0.8\text{E-}7$
RCBT-A	$2.0 \pm 0.1\text{E-}1$	<2E-1	<9E-6	$2.1 \pm 0.2\text{E-}4$	$1.0 \pm 0.1\text{E-}6$
RCBT-B	$4.4 \pm 0.6\text{E-}2$	<5E-1	<1E-5	$6.3 \pm 0.6\text{E-}5$	$2.6 \pm 0.4\text{E-}7$
RCBT-C	$1.4 \pm 0.1\text{E-}2$	<2E-1	<2E-5	$3.1 \pm 0.4\text{E-}5$	$4.3 \pm 0.4\text{E-}7$

TABLE 5. TMI-2 RCS AND RCBT SOLID SAMPLE ANALYSIS: ALPHA ISOTOPIIC MEASUREMENTS
($\mu\text{Ci/ml}$ of filtered solution corrected to T_0)

Sample	^{238}Pu	$^{239,240}\text{Pu}$	^{241}Am	^{242}Cm	^{244}Cm	^{235}U	^{234}U	^{238}U
RCS-1	$3.7 \pm 0.2\text{E-6}$	$3.25 \pm 0.09\text{E-5}$	$5.7 \pm 0.3\text{E-7}$	$7 \pm 2\text{E-7}$	$<6\text{E-9}$	$5 \pm 2\text{E-7}$	$2.2 \pm 0.2\text{E-5}$	$4 \pm 1\text{E-7}$
RCS-2	$9 \pm 5\text{E-8}$	$2.4 \pm 0.8\text{E-7}$	$4.5 \pm 0.6\text{E-7}$	$<3\text{E-7}$	$<4\text{E-8}$	$<2\text{E-8}$	$<5\text{E-8}$	$4 \pm 1\text{E-8}$
RCBT-A	$1.3 \pm 0.2\text{E-6}$	$1.04 \pm 0.05\text{E-5}$	$2.1 \pm 0.1\text{E-7}$	$8 \pm 2\text{E-8}$	$<5\text{E-9}$	$<2\text{E-8}$	$<5\text{E-8}$	$6 \pm 3\text{E-8}$
RCBT-B	$<5\text{E-8}$	$1.4 \pm 0.5\text{E-7}$	$<6\text{E-8}$	$<1\text{E-7}$	$<4\text{E-8}$	$<2\text{E-8}$	$<8\text{E-8}$	$<2\text{E-8}$
RCBT-C	$<6\text{E-8}$	$3.9 \pm 0.5\text{E-7}$	$1.3 \pm 0.6\text{E-8}$	$<1\text{E-8}$	$5 \pm 3\text{E-9}$	$<9\text{E-8}$	$4 \pm 2\text{E-7}$	$5 \pm 1\text{E-7}$

TABLE 6. TMI-2 RCS AND RCBT LIQUID SAMPLE GAMMA SPECTROMETRY ANALYSIS AFTER FILTRATION

Sample	T ₀	μCi/ml Corrected to T ₀	
		¹³⁴ Cs After Filtration	¹³⁷ Cs After Filtration
RCS-1	March 29, 1979	8.77 ± 0.07E+1	3.56 ± 0.02E+2
RCS-2	August 8, 1980	4.92 ± 0.08	2.83 ± 0.02E+1
RCBT-A	December 20, 1979	7.57 ± 0.07	3.38 ± 0.02E+1
RCBT-B	January 28, 1980	7.79 ± 0.08	3.71 ± 0.02E+1
RCBT-C	February 4, 1980	1.050 ± 0.005E+1	5.05 ± 0.01E+1

TABLE 7. TMI-2 RCS AND RCBT LIQUID SAMPLE GAMMA SPECTROMETRY ANALYSIS BEFORE AND AFTER FILTRATION

Sample	T _o	μCi/ml Corrected to Time of Measurements, December 15, 1980				
		¹³⁴ Cs		¹³⁷ Cs		⁶⁰ Co
		Before Filtration	After Filtration	Before Filtration	After Filtration	Before Filtration ^a
RCS-1	March 29, 1979	5.32 ± 0.05E+1	5.11 ± 0.04E+1	3.35 ± 0.02E+2	3.42 ± 0.02E+2	2.1 ± 0.3E-1
RCS-2	August 8, 1980	4.41 ± 0.03	4.45 ± 0.06	2.92 ± 0.01E+1	2.81 ± 0.02E+1	--
RCBT-A	December 20, 1979	5.58 ± 0.05	5.43 ± 0.01	3.50 ± 0.01E+1	3.31 ± 0.02E+1	--
RCBT-B	January 28, 1980	5.58 ± 0.04	5.71 ± 0.06	3.65 ± 0.01E+1	3.55 ± 0.02E+1	--
RCBT-C	February 4, 1980	8.57 ± 0.05	7.74 ± 0.04	5.26 ± 0.02E+1	4.83 ± 0.01E+1	--

a. No radionuclides were detected after filtration.

TABLE 8. TMI-2 RCS AND RCBT FILTRATE SAMPLE ANALYSIS: pH, CONDUCTIVITY, SPECIFIC GRAVITY, ANIONS, AND ELEMENTAL

Sample	pH	Conductivity ($\mu\text{mho/cm}$)	Specific Gravity	Elemental Analysis by Alternative Current Spark Emission Spectrometry ($\mu\text{g/ml}$)							
				Al	B	Ca	Fe	K	Mg	Na	Si
RCS-1	8.42	2.98	1.0054	3	2300	1	<1	<0.1	0.2	1050	3
RCS-2	7.94	2.72	1.0080	4	3560	3	13	<0.1	0.9	795	3
RCBT-A	8.00	1.18	1.0021	1	1400	8	<0.6	<0.1	2	360	2
RCBT-B	8.63	1.33	1.0014	0.8	760	8	<0.6	<0.1	2	423	2
RCBT-C	8.64	1.36	1.0012	1	860	5	<0.6	0.3	0.9	383	3

12

Sample	Anions Analysis by Ion Chromatography ^{a,b} ($\mu\text{g/ml}$)					
	F^-	Cl^-	Br^-	SO_4^{-2}	PO_4^{-3}	NO_3^-
RCS-1	<1.0	2.1	<10	28	<10	10.3
RCS-2	<0.5	<0.1	<1.0	23	<1.0	3.1
RCBT-A	<1.0	5.0	<10	147	<10	3.2
RCBT-B	2.0	11.7	<10	92	<10	3.2
RCBT-C	<1.0	10.3	<10	205	<10	2.0

a. High levels of boron interfered with the NO_2^- analyses.

b. An unidentified peak in RCS-2 was tentatively identified as the oxalate ion $\text{C}_2\text{O}_4^{-2}$ at a level of 15.6 $\mu\text{g/ml}$.

TABLE 9. TMI-2 RCS AND RCBT FILTRATE ANALYSIS: ^3H , ^{14}C , ^{144}Ce , ^{129}I AND ALPHA AND BETA ISOTOPES ($\mu\text{Ci/ml}$ Corrected to T_0)

Sample	T_0	^3H	^{14}C	^{144}Ce	^{129}I	Beta Isotopic				
						^{90}Sr	^{89}Sr	^{91}Y	^{55}Fe	^{63}Ni
RCS-1	March 29, 1979	1.71 ± 0.08	$7.21 \pm 0.07\text{E-}4$	$1.80 \pm 0.09\text{E-}2$	$5.3 \pm 0.3\text{E-}6$	$5.7 \pm 0.3\text{E-}4$	$<4\text{E-}1$	$5.9 \pm 0.5\text{E-}2$	$<5\text{E-}2$	$1.4 \pm 0.1\text{E-}4$
RCS-2	August 14, 1980	$8.5 \pm 0.4\text{E-}2$	$7.0 \pm 0.7\text{E-}5$	$<9\text{E-}5$	$3.4 \pm 0.2\text{E-}6$	$2.3 \pm 0.1\text{E+}1$	<400	$2.3 \pm 0.2\text{E-}4$	$1.8 \pm 0.2\text{E-}3$	$<3\text{E-}5$
RCBT-A	December 20, 1979	$2.1 \pm 0.1\text{E-}1$	$1.04 \pm 0.01\text{E-}4$	$<2\text{E-}4$	$4.4 \pm 0.2\text{E-}6$	1.2 ± 0.1	$<8\text{E-}1$	$<5\text{E-}6$	$5.4 \pm 0.5\text{E-}6$	$1.7 \pm 0.1\text{E-}5$
RCBT-B	January 28, 1980	$2.6 \pm 0.1\text{E-}1$	$3.34 \pm 0.03\text{E-}4$	$<4\text{E-}6$	$4.4 \pm 0.2\text{E-}6$	$3.2 \pm 0.2\text{E-}1$	<4	$<9\text{E-}5$	$<2\text{E-}5$	$<3\text{E-}5$
RCBT-C	February 4, 1980	$1.57 \pm 0.08\text{E-}1$	$1.63 \pm 0.02\text{E-}4$	$<2\text{E-}4$	$7.9 \pm 0.7\text{E-}6$	$5.3 \pm 0.3\text{E-}1$	<6	$8 \pm 6\text{E-}5$	$<2\text{E-}5$	$<3\text{E-}5$

						Alpha Isotopic				
		^{238}Pu	$^{239,240}\text{Pu}$	^{235}U	^{234}U	^{238}U	^{241}Am	^{242}Cm	^{244}Cm	
		$2.7 \pm 0.2\text{E-}6$	$3.8 \pm 0.1\text{E-}5$	$2.7 \pm 0.3\text{E-}7$	$4.2 \pm 0.2\text{E-}6$	$1.0 \pm 0.8\text{E-}6$	$2.4 \pm 0.2\text{E-}7$	$6 \pm 2\text{E-}7$	$1.1 \pm 0.2\text{E-}7$	
		$<9\text{E-}8$	$3.2 \pm 0.4\text{E-}7$	$<2\text{E-}8$	$<8\text{E-}8$	$<2\text{E-}8$	$8 \pm 3\text{E-}8$	$<6\text{E-}8$	$8 \pm 5\text{E-}8$	
		$<1\text{E-}8$	$<4\text{E-}8$	$<2\text{E-}8$	$<6\text{E-}8$	$1.8 \pm 0.4\text{E-}8$	$7 \pm 5\text{E-}9$	$<7\text{E-}9$	$2.3 \pm 0.5\text{E-}8$	
		$4.7 \pm 0.6\text{E-}8$	$3 \pm 1\text{E-}8$	$<3\text{E-}8$	$<8\text{E-}8$	$7 \pm 3\text{E-}8$	$<4\text{E-}8$	$7 \pm 2\text{E-}7$	$2.0 \pm 0.5\text{E-}7$	
		$<1\text{E-}7$	$3.0 \pm 0.6\text{E-}7$	$<2\text{E-}8$	$<6\text{E-}8$	$3 \pm 1\text{E-}8$	$1.4 \pm 0.6\text{E-}8$	$9 \pm 3\text{E-}8$	$5 \pm 4\text{E-}9$	

ANALYSES AT EG&G IDAHO, INC.

The archive samples were received from ENICO. The samples were manually shaken and a 0.1-ml aliquot of each was pipetted onto glass cover slides and dried to give point sources. The activities of these samples were measured by a Ge(Li) gamma-ray spectrometry system calibrated with NBS-standard reference materials.

The ^{90}Sr determination was made by separation of the strontium through a series of precipitations with a strontium carrier added to determine chemical recovery efficiency. The ^{90}Sr activity was then determined by direct counting using a calibrated end-window beta proportional counter.

A radiochemical separation of the iodine was performed with a small amount of ^{125}I added to determine chemical recovery. Iodine-129 was determined by neutron activation analysis (NAA) based on the $^{129}\text{I} (n, \gamma) ^{130}\text{I}$ reaction. The induced ^{130}I activity was then measured by gamma spectroscopy.

The fissile material content was determined by a delayed fission neutron technique. Three ml of the samples were pipetted into polyethylene capsules. Standard reference samples were prepared with 3 ml of known ^{235}U solutions, and blank samples were prepared with distilled water. Using a pneumatic transfer system, the samples, standards, and blanks were irradiated for 60 s in the Coupled Fast Reactivity Monitoring Facility (CFRMF) with a flux of $5.5 \times 10^{11} \text{ n/cm}^2/\text{s}$. The capsules were allowed to decay for 40 s and then counted with a neutron detector system for 60 s. The fissile content was then calculated as if it were all ^{235}U , because this method does not distinguish fissile isotopes.

The results of the EG&G Idaho method discussed above are listed in Table 10.

TABLE 10. TMI-2 RCS AND RCBT SOLID SAMPLE ANALYSIS^a

Sample	¹³⁷ Cs (μ Ci/ml)	¹³⁴ Cs (μ Ci/ml)	⁹⁰ Sr (μ Ci/ml)	¹²⁹ I (μ Ci/ml)	Fissile Material ^b (μ g/ml)
RCS-1	3.53 \pm 0.01E+2	9.62 \pm 0.05E+1	8.00 \pm 0.09E-2	7.4 \pm 0.4E-5	6.7 \pm 1.7E-3
RCS-2	3.06 \pm 0.02E+1	5.27 \pm 0.08	2.35 \pm 0.07E+1	7.1 \pm 0.3E-6	6.7 \pm 1.7E-3
RCBT-A	3.47 \pm 0.02E+1	7.34 \pm 0.07	1.03 \pm 0.07	9.8 \pm 0.5E-6	6.7 \pm 1.7E-3
RCBT-B	3.96 \pm 0.02E+1	8.00 \pm 0.08	3.55 \pm 0.08E-1	8.4 \pm 0.4E-6	<3.3E-3
RCBT-C	5.69 \pm 0.03E+1	1.12 \pm 0.09E+1	8.32 \pm 0.09E-1	1.7 \pm 0.08E-5	<3.3E-3

a. Decay corrected to T_0 . Samples analyzed as received (no filtration performed). Uncertainties are based on counting statistics only; values are for two sigma confidence level.

b. Expressed as ²³⁵U equivalent.

Two aliquots of reactor coolant sample contained in plastic bottles were received from INEL. One was used for analysis, while the other was archived. The analyzed sample was determined to weigh 10.313 g and to have a pH of 8. Considerable plate-out of nuclides was observed on the walls of the shipping container. By combining analyses of the coolant and the shipping bottle, and applying correction factors of gamma-ray measurements to obtain activities of the original sample, concentration of most of the nuclides was calculated. Tritium, ^{63}Ni , ^{55}Fe , ^{129}I , ^{14}C , ^{235}U , and ^{238}U concentrations were determined on the initial sample only.

Three milliliters (3 ml) of the original sample were diluted to one hundred milliliters (100 ml) in 2% hydrochloric acid and transferred to a one-hundred-twenty-five milliliter (125 ml) polyethylene bottle for gamma isotopic analysis.

One-half milliliter (0.5 ml) of original sample was diluted to one hundred milliliters in 2% hydrochloric acid in a volumetric flask. This 1:200 dilution was used for most of the radiochemical analyses performed on the sample.

Initially, a gamma isotopic analysis of the sample was performed using Ge(Li) pulse-height spectrometry. Only ^{134}Cs and ^{137}Cs were detected due to their relative high activity compared to other nuclides in the sample. Cesium was removed from the sample by scavenging with ammonium molybdophosphate (AMP). Two scavenges were performed serially, each removing more than 99% of the cesium nuclides. Other nuclides were also removed from the sample to varying degrees, up to approximately 57.0% for ^{144}Ce . Table 11 compares activities determined on the sample after the first and second cesium scavenges. The final column represents the fractional percentage of each nuclide removed by the second cesium scavenge. By assuming that the same percentages are applicable to the first cesium scavenge, calculations of activities in the original sample were made for each nuclide other than cesium. These values were combined with measured activities of the nuclide deposited in the shipping bottle to obtain the concentrations for the gamma-ray emitters listed in Table 12.

The lanthanides were separated from the sample and precipitated as oxalates by the addition of a cerium carrier. Yttrium, which behaves as a lanthanide, was coprecipitated. The 64-hr half-life yttrium was allowed to decay for 71 hours before gamma-ray spectrometry to reduce the signal from its bremsstrahlung radiation. Even so, the only lanthanide that was quantitatively detected was ^{144}Ce .

TABLE 11. TMI-2 RCS-2 CESIUM SCAVENGES
 ($\mu\text{Ci/ml}$; all values decay corrected to March 30, 1981)

<u>Nuclide</u>	<u>Original Sample</u>	<u>Cesium Removed 1st Scavenge</u>	<u>Cesium Removed 2nd Scavenge</u>	<u>Percent Removed by 2nd Scavenge</u>
^{134}Cs	3.33E+1	2.62E-2	5.18E-5	0.998
^{137}Cs	2.27E+2	1.31E-1	2.56E-4	0.998
$^{144}\text{Ce/Pr}$	--	9.44E-3	4.06E-3	0.570
^{125}Sb	--	3.59E-2	3.40E-2	0.053
^{60}Co	--	7.20E-4	6.59E-4	0.085
$^{106}\text{Ru/Rh}$	--	2.01E-3	1.64E-3	0.184
^{95}Nb	--	1.54E-4	1.10E-4	0.286
^{58}Co	--	3.34E-5	2.28E-5	0.317
^{54}Mn	--	4.40E-5	3.30E-5	0.250
$^{110\text{m}}\text{Ag}$	--	1.38E-4	1.05E-4	0.239

TABLE 12. TMI-2 RCS-1 CONCENTRATIONS OF RADIONUCLIDE AND MASS OF CESIUM
(all values, unless otherwise noted, are decay corrected to
March 30, 1981)

Nuclide	Concentration: $\mu\text{Ci/ml}$ of Original Sample	Statistical Uncertainty ^c ($\pm 2 \sigma$)
^{134}Cs	3.33E+1	2.5E-0
^{137}Cs	2.27E+2	9.2E-1
$^{144}\text{Ce/Pr}$	4.04E-2	2.7E-3
^{125}Sb	5.76E-2	1.2E-2
^{60}Co	2.18E-3	4.5E-4
$^{106}\text{Ru/Rh}$	1.10E-2	4.6E-3
^{51}Cr	1.54E-3	5.2E-4
$^{110\text{m}}\text{Ag}$	1.08E-3	2.2E-4
^{95}Nb	2.16E-4	7.1E-5
^{95}Zr	2.33E-5	4.3E-6
^{58}Co	<5.38E-4	
^{54}Mn	<4.71E-4	
^3H	6.45E-1 ^b	1.0E-2
^{89}Sr	1.08E-2	1.5E-3
^{90}Sr	8.66E-2	7.4E-4
^{63}Ni (05-01-81)	<1.04E-3 ^b	
^{55}Fe (05-11-81)	<2.44E-2 ^b	
^{129}I	1.25E-4 ^b	1.0E-5
^{14}C	5.66E-4 ^b	5.7E-5
$^{239,240}\text{Pu}$	1.40E-3	5.0E-5
^{238}Pu	1.19E-4	5.0E-6
^{241}Am	1.99E-5	2.5E-6
$^{242,243}\text{Cm}$	2.04E-5	4.0E-6
^{244}Cm	1.38E-5	1.7E-6
^{235}U	<4.53E-7 ^b	
^{238}U	5.00E-7 ^b	1.7E-7

a. Total cesium by Graphite Furnace Atomic Spectroscopy $1.2\text{E}1 \pm 0.3\text{E}1 \mu\text{g/ml}$.

b. Concentrations of these nuclides were determined by direct measurements of the coolant sample, and do not include any that absorbed onto the shipping container.

c. Counting uncertainty only.

The tritium concentration was measured in a known fraction of the supernate after the removal of radiocesium and the lanthanides. This sample was distilled from alkaline permanganate solution. The purified condensate was collected and counted by the liquid-scintillation technique.

Similar to the tritium analysis, ^{14}C analysis was done by distillation and liquid-scintillation counting. The ^{14}C distillation involved use of an oxidizing reflux system and a liquid adsorber downstream to quantitatively capture the $^{14}\text{CO}_2$ gas. A known spike of ^{14}C was distilled prior to the sample and recovery of 94.3% was obtained. This yield was used in determining the sample concentration.

The sample was analyzed for $^{89,90}\text{Sr}$ by a nitrate/carbonate gravimetric method. Five ml of the 1:200 dilution were used for this analysis.

The following general method was used to analyze for ^{129}I . Two ml of unacidified sample and NaI carrier were made basic to a pH of 8.0 and loaded onto a Dowex 50 anion exchange resin. Cs, Sr, and other cations were eluted off the resin. The ^{129}I and carrier were stripped from the resin, extracted into carbon-tetrachloride, and back extracted into water. Finally, the iodine was precipitated as CuI , filtered onto glass-fiber paper, and counted on a thin-window NaI(Tl) detector.

Analysis of ^{55}Fe and ^{63}Ni were performed jointly on a 1.0-ml aliquot of raw sample. Iron and nickel carriers were added, and the iron was precipitated as the hydroxide, using ammonium hydroxide. The nickel remained in solution and was separated in the filtrate. After a series of decontamination steps, the iron hydroxide was counted on the thin-window NaI(Tl) detector, and the nickel was counted in the liquid-scintillation counter.

The uranium and transuranic series were analyzed using standard methods involving liquid-liquid extractions and electroplating of purified nuclides. The plates were counted on an alpha pulse-height analyzer with a Si(Au) detector.

Atomic absorption spectrophotometry was employed for determining total cesium. The high concentrations of ^{134}Cs and ^{137}Cs in the sample precluded the use of an acetylene flame on undiluted samples because gross contamination of the instrument would result. A quantitatively diluted sample was used in the high-temperature graphite furnace. However, it was necessary to experiment to find suitable diluents for the sample and the optimum operating settings for the furnace. After establishing peak conditions, the sample was analyzed. The results were concordant when the sample was run under two sets of conditions.

DISCUSSION

RCS-1

Table 13 compares the RCS-1 results from the three laboratories. The ^{134}Cs , ^{137}Cs numbers from ENICO and EG&G Idaho agree very well, the ^{90}Sr and ^{129}I numbers agree fairly well, considering the different techniques used, but the fissile material numbers differ considerably. The reason for the large difference in fissile material content is not known.

When comparing the SAI results with the ENICO results, the idea that the samples are not the same comes to mind. This idea is based on the following:

- o The Cs numbers differ considerably. This is one of the more straightforward measurements.
- o The ^{129}I , ^{235}U , ^{238}U , and transuranic numbers differ by factors of up to 25.
- o The radiation survey readings taken on October 9, 1980 by GPU gave the 125-ml RCS sample reading as 800 mR/hr gamma and the 20 ml RCS sample reading as 3.2 R/hr gamma.
- o There is no documentation available to verify if in fact the samples are identical.

RCS-2, RCBT-A, RCBT-B, and RCBT-C

Table 14 compares the ENICO and EG&G Idaho results for the four remaining samples. The results agree very well, with the noticeable exception of the fissile material content. Again, the reason for this discrepancy is not known.

TABLE 13. COMPARISON OF THE TMI-2 RCS-1 MEASUREMENTS
($\mu\text{Ci/ml}$ unless otherwise noted; decay corrected to T_0)

<u>Selected Nuclides</u>	<u>ENICO</u>	<u>EG&G Idaho</u>	<u>SAI</u>
^{134}Cs	8.80E+1	9.62E+1	6.53E+1
^{137}Cs	3.57E+2	3.53E+2	2.38E+2
^{90}Sr	1.0E-2	8.0E-2	9.1E-2
^{129}I	5.3E-6	7.4E-5	1.25E-4
Fissile material ($\mu\text{g/ml}$)	3.5E-1	6.7E-3	>2.3E-2
^{125}Sb	2.4E-2	--a	9.6E-2
^{60}Co	2.0E-3	--a	2.8E-3
$^{239}, ^{240}\text{Pu}$	7.0E-5	--a	1.4E-3
^{241}Am	8.1E-7	--a	2.0E-5
^{235}U	7.9E-7	--a	<4.5E-7
^{238}U	1.4E-6	--a	5.0E-7

a. Not analyzed.

TABLE 14. COMPARISON OF ENICO AND EG&G IDAHO MEASUREMENTS
($\mu\text{Ci/ml}$ unless otherwise noted; decay corrected T_0)

<u>Nuclide</u>	<u>Laboratory</u>	<u>RCS-2</u>	<u>RCBT-2</u>	<u>RCBT-B</u>	<u>RCBT-C</u>
^{134}Cs	ENICO	4.93	7.68	7.88	1.05E+1
	EG&G Idaho	5.27	7.34	8.00	1.12E+1
^{137}Cs	ENICO	2.84E+1	3.43E+1	3.76E+1	5.06E+1
	EG&G Idaho	3.06E+1	3.47E+1	3.96E+1	5.69E+1
^{90}Sr	ENICO	2.34E+1	1.4	3.64E-1	5.44E-1
	EG&G Idaho	2.35E+1	1.03	3.55E-1	8.32E-1
^{129}I	ENICO	3.4E-6	4.4E-6	4.4E-6	7.9E-6
	EG&G Idaho	7.1E-6	9.8E-6	8.4E-6	1.7E-5
Fissile Material ($\mu\text{g/ml}$)	ENICO	>6.7E-6	>1.7E-4	>2.8E-6	>1.13E-5
	EG&G Idaho	6.7E-3	6.7E-3	<3.3E-3	<3.3E-3

In all but one case, the radionuclide concentrations had diminished a varying amount. These changes can be attributed to (a) losses from the primary loop, (b) makeup water (a dilution effect), and (c) radioactive decay. The ^{90}Sr increase is probably due to the leaching of the strontium from the reactor core. Table 1 shows large differences in particle size distribution and total solids. The lack of particles $>5\mu$ indicates that they settled somewhere in low points of the RCS where natural circulation due to decay heat was not great enough to suspend them. The large increase in the mass of the particles between $0.45\text{-}1.2\ \mu$ size indicate that a salt or salts are being precipitated into the water and are being carried over and suspended in the water throughout the entire RCS.⁶

REFERENCES

1. T.E. Cox, EG&G Idaho, letter to G.R. Eidam, TEC-22-81, Exxon Nuclear Idaho RCS and RCBT Sample Report, July 9, 1981.
2. C. P. Willis, communication, EG&G Idaho, Inc., First TMI Samples, June 17, 1981.
3. G. Duggan, Science Applications Inc., letter to R. L. Nitschke, Characterization of TMI Unit 2 Post-Accident Primary Coolant, August 1981.
4. C. W. Filby, Exxon Nuclear Idaho, letter to T.E. Cox, TMI RCS and RCBT Sample Report, June 25, 1981.
5. J. A. Daniel, Memorandum to Distribution, Analysis of RCS and RCBT Samples, May 13, 1981.
6. F. Y. Tsang, EG&G Idaho, letter to D.W. Croucher, FYT-4-81, Industry Review and Comment on the Information for the Defueling Program, August 18, 1981.