

Fresh-Core Reload of the Neutron Radiography (NRAD) Reactor with Uranium(20)-Erbium- Zirconium-Hydride Fuel

**John D. Bess
Thomas L. Maddock
Margaret A. Marshall
Leland M. Montierth
Ning Zhang
Ann Marie Phillips
Kenneth A. Schreck
J. Blair Briggs
Eric W. Woolstenhulme
John M. Bolin
Anthony Veca
Richard D. McKnight
Richard M. Lell**

March 2013

The INL is a U.S. Department of Energy National Laboratory
operated by Battelle Energy Alliance



Fresh-Core Reload of the Neutron Radiography (NRAD) Reactor with Uranium(20)-Erbium-Zirconium- Hydride Fuel

**John D. Bess
Thomas L. Maddock
Margaret A. Marshall¹
Leland M. Montierth
Ning Zhang
Ann Marie Phillips
Kenneth A. Schreck
J. Blair Briggs
Eric W. Woolstenhulme
John M. Bolin²
Anthony Veca²
Richard D. McKnight³
Richard M. Lell³**

¹University of Idaho

²General Atomics

³Argonne National Laboratory

March 2013

**Idaho National Laboratory
Idaho Falls, Idaho 83415**

<http://www.inl.gov>

**Prepared for the
U.S. Department of Energy
Office of Nuclear Energy
Under DOE Idaho Operations Office
Contract DE-AC07-05ID14517**

NEA/NSC/DOC(2006)1

Fundamental - FUND

NRAD-FUND-RESR-001
CRIT-REAC-COEF

**FRESH-CORE RELOAD OF THE NEUTRON RADIOGRAPHY
(NRAD) REACTOR WITH URANIUM(20)-ERBIUM-
ZIRCONIUM-HYDRIDE FUEL**

Evaluators

**John D. Bess
Thomas L. Maddock
Idaho National Laboratory**

**Margaret A. Marshall
University of Idaho/Idaho National Laboratory**

Internal Reviewers

**Leland M. Montierth
Ning Zhang
Ann Marie Phillips
Kenneth A. Schreck
J. Blair Briggs
Eric C. Woolstenhulme
Idaho National Laboratory**

**John M. Bolin
Anthony Veca
General Atomics**

Independent Reviewers

**Richard D. McKnight
Richard M. Lell
Argonne National Laboratory**

Status of Compilation / Evaluation / Peer Review

Section 1	Compiled	Independent Review	Working Group Review	Approved
1.0 DETAILED DESCRIPTION	YES	YES	YES	YES
1.1 Description of the Critical and / or Subcritical Configuration	YES	YES	YES	YES
1.2 Description of Buckling and Extrapolation Length Measurements	NA	NA	NA	NA
1.3 Description of Spectral Characteristics Measurements	NA	NA	NA	NA
1.4 Description of Reactivity Effects Measurements	YES	YES	YES	YES
1.5 Description of Reactivity Coefficient Measurements	YES	YES	YES	YES
1.6 Description of Kinetics Measurements	NA	NA	NA	NA
1.7 Description of Reaction-Rate Distribution Measurements	NA	NA	NA	NA
1.8 Description of Power Distribution Measurements	NA	NA	NA	NA
1.9 Description of Isotopic Measurements	NA	NA	NA	NA
1.10 Description of Other Miscellaneous Types of Measurements	NA	NA	NA	NA
Section 2	Evaluated	Independent Review	Working Group Review	Approved
2.0 EVALUATION OF EXPERIMENTAL DATA	YES	YES	YES	YES
2.1 Evaluation of Critical and / or Subcritical Configuration Data	YES	YES	YES	YES
2.2 Evaluation of Buckling and Extrapolation Length Data	NA	NA	NA	NA
2.3 Evaluation of Spectral Characteristics Data	NA	NA	NA	NA
2.4 Evaluation of Reactivity Effects Data	YES	YES	YES	YES
2.5 Evaluation of Reactivity Coefficient Data	NA	NA	NA	NA
2.6 Evaluation of Kinetics Measurements Data	NA	NA	NA	NA
2.7 Evaluation of Reaction Rate Distributions	NA	NA	NA	NA
2.8 Evaluation of Power Distribution Data	NA	NA	NA	NA
2.9 Evaluation of Isotopic Measurements	NA	NA	NA	NA
2.10 Evaluation of Other Miscellaneous Types of Measurements	NA	NA	NA	NA

Section 3	Compiled	Independent Review	Working Group Review	Approved
3.0 BENCHMARK SPECIFICATIONS	YES	YES	YES	YES
3.1 Benchmark-Model Specifications for Critical and / or Subcritical Measurements	YES	YES	YES	YES
3.2 Benchmark-Model Specifications for Buckling and Extrapolation Length Measurements	NA	NA	NA	NA
3.3 Benchmark-Model Specifications for Spectral Characteristics Measurements	NA	NA	NA	NA
3.4 Benchmark-Model Specifications for Reactivity Effects Measurements	YES	YES	YES	YES
3.5 Benchmark-Model Specifications for Reactivity Coefficient Measurements	NA	NA	NA	NA
3.6 Benchmark-Model Specifications for Kinetics Measurements	NA	NA	NA	NA
3.7 Benchmark-Model Specifications for Reaction-Rate Distribution Measurements	NA	NA	NA	NA
3.8 Benchmark-Model Specifications for Power Distribution Measurements	NA	NA	NA	NA
3.9 Benchmark-Model Specifications for Isotopic Measurements	NA	NA	NA	NA
3.10 Benchmark-Model Specifications of Other Miscellaneous Types of Measurements	NA	NA	NA	NA
Section 4	Compiled	Independent Review	Working Group Review	Approved
4.0 RESULTS OF SAMPLE CALCULATIONS	YES	YES	YES	YES
4.1 Results of Calculations of the Critical or Subcritical Configurations	YES	YES	YES	YES
4.2 Results of Buckling and Extrapolation Length Calculations	NA	NA	NA	NA
4.3 Results of Spectral Characteristics Calculations	NA	NA	NA	NA
4.4 Results of Reactivity Effect Calculations	YES	YES	YES	YES
4.5 Results of Reactivity Coefficient Calculations	NA	NA	NA	NA
4.6 Results of Kinetics Parameter Calculations	NA	NA	NA	NA
4.7 Results of Reaction-Rate Distribution Calculations	NA	NA	NA	NA
4.8 Results of Power Distribution Calculations	NA	NA	NA	NA
4.9 Results of Isotopic Calculations	NA	NA	NA	NA
4.10 Results of Calculations of Other Miscellaneous Types of Measurements	NA	NA	NA	NA
Section 5	Compiled	Independent Review	Working Group Review	Approved
5.0 REFERENCES	YES	YES	YES	YES
Appendix A: Computer Codes, Cross Sections, and Typical Input Listings	YES	YES	YES	YES

FRESH-CORE RELOAD OF THE NEUTRON RADIOGRAPHY (NRAD) REACTOR WITH URANIUM(20)-ERBIUM-ZIRCONIUM-HYDRIDE FUEL**IDENTIFICATION NUMBER:** NRAD-FUND-RESR-001
CRIT-REAC-COEF**KEY WORDS:** acceptable, criticality, dry tube, enriched uranium, erbium, graphite, graphite-reflected, light water, neutron radiography, NRAD, reflector worth, research reactor, rod worth, startup measurements, thermal, TRIGA, uranium, uranium-erbium-zirconium-hydride fuel, water-reflected, zirconium-hydride, zirconium-hydride-moderated**SUMMARY INFORMATION****1.0 DETAILED DESCRIPTION**

The neutron radiography (NRAD) reactor is a 250 kW TRIGA[®] (Training, Research, Isotopes, General Atomics) Mark II^{a,b} tank-type research reactor located in the basement, below the main hot cell, of the Hot Fuel Examination Facility (HFEF) at the Idaho National Laboratory (INL). It is equipped with two beam tubes with separate radiography stations for the performance of neutron radiography irradiation on small test components.^c

The NRAD reactor is currently under the direction of the Battelle Energy Alliance (BEA) and is operated and maintained by the INL and Hot Cell Services Division. It is primarily used for neutron radiography analysis of both irradiated and unirradiated fuels and materials. Typical applications for examining the internal features of fuel elements and assemblies include fuel pellet separations, fuel central-void formation, pellet cracking, evidence of fuel melting, and material integrity under normal and extreme conditions. Examination of the behavior of large test loops and assemblies can also be performed. Due to the intense gamma activity of most irradiated specimens, the HFEF uses an indirect radiography, where a beam of neutrons passes through a specimen, strikes a gamma-insensitive metal foil (typically indium or dysprosium, for epithermal or thermal neutron spectra, respectively), and activates the foil. The foil can then be placed against a sheet of x-ray photographic film. X-rays from the metal foil then render an image on the film, which is then developed. While this method takes longer than the conventional direct method, the results eliminate gamma interference and are more detailed. Neutron tomography capabilities are being developed, where radiographs are obtained from different rotational angles and digitized to reconstruct cross-sections of a specimen. Direct radiography, such as Polaroid or track-etch radiography, and in-tank irradiations and/or experiments with small in-core samples can also be performed in the NRAD reactor.

The NRAD core is designed for steady-state operation with or without in-core and/or in-tank experiments. The combined reactivity worth of all removable experiments within the reactor tank is limited to less than \$0.50.

^a TRIGA[®] Nuclear Reactors, General Atomics, <http://triga.ga.com/> (Accessed October 15, 2009).

^b D. M. Fouquet, J. Razvi, W. L. Whittemore, "TRIGA Research Reactors: A Pathway to the Peaceful Applications of Nuclear Energy," *Nuclear News*, **46**(12), 46-56 (2003).

^c "NRAD Safety Analysis Report," DSA-005-NRAD rev. 5, Idaho National Laboratory (April 2, 2009). [This reference is not available for public release.]

The NRAD reactor is a TRIGA-conversion-type reactor originally located at the Puerto Rico Nuclear Center (PRNC). It was converted to a TRIGA-FLIP-(Fuel Life Improvement Program)-fueled system (70% ^{235}U) in 1971. The 2-MW Puerto Rico research reactor was then closed in 1976; a portion of the TRIGA reactor fuel elements and other components (with a single radiography beam line) were moved in 1977 by the US Department of Energy (DOE) to the Argonne National Laboratory (West), which is now part of INL, in Idaho Falls, Idaho, and rebuilt as the NRAD reactor. The NRAD reactor was first brought to critical in October 1977,^a and then became operational in 1978. A second beam line was added in 1982.^b

The Reduced Enrichment for Research and Test Reactors (RERTR) Program, in support of the Global Threat Reduction Initiative (GTRI), required conversion of all civilian reactor facilities from highly enriched uranium (HEU) to low enriched uranium (LEU) fuel (<20% ^{235}U).^c Therefore, the NRAD reactor core comprised of FLIP fuel was completely defueled by August 26, 2009. Refueling with LEU began on September 17, 2009 and initial approach to critical began on March 9, 2010. The freshly fueled LEU core achieved criticality with 56 fuel elements on March 19, 2010 at 14:22:58. Key management, staff, and operators present during the initial critical included Ken Schreck (Facility Manager), Ryan Archibald (Reactor Operator), Tom Maddock (System Engineer), Randy Damiana (LEU Conversion Project Manager), Rick Cain (HFEF Staff serving as Auditor), Ann Marie Phillips (LEU Conversion Project Manager), Steve Sorrell (DOE-ID Regulator), Scott Ferrara (DOE-ID Regulator), Gary Engelstad (Refueling Operator), Jarod Littell (Reactor Operator), and Orin Harman (Reactor Operator in Training).

Start-up testing for the HEU/LEU fuel conversion of the NRAD TRIGA reactor began on March 9, 2010 and was completed on June 7, 2010. Measurements included the neutron multiplication in the approach to initial criticality, and the determination of control rod worths, excess reactivity, and shutdown margin for the initial core configuration (56 fuel elements). An additional cluster containing four fuel elements was loaded into the NRAD core, and the operational core was then brought to cold critical with 60 fuel elements on March 31, 2010. Control rod worths, excess reactivity, and shutdown margin were also measured for the operational core configuration. Calorimetric power calibrations were performed up to 250 kW, and excess reactivity was determined at full power (250 kW). Additional measurements were performed to evaluate the worth of some of the graphite reflector blocks used in the core and the worth of the dry tube available for experimental use.

Available data regarding the materials and configuration of the NRAD reactor is limited to the start-up test plan,^d measurement results from the start-up tests,^e safety analysis reports,^{f,g} a system design

^a A. A. Weeks, D. P. Pruett, and C. C. Heidel, "Modifications to the NRAD Reactor (1997 to Present)," CONF-8604117—1, *Proc. 10th U.S. TRIGA User's Conference*, College Station, Texas (April 7-9, 1986).

^b G. R. Imel, G. C. McClellan, and D. P. Pruett, "The Neutron Radiography Reactor (NRAD)," CONF-900873--2, *Proc. 1st Int. Top. Mtg. Neutron Radiography System Design and Characterization*, Pembroke, Canada (August 28-30, 1990).

^c C. Landers, "Reactor Identified for Conversion, Reduced Enrichment for Research and Test Reactors (RERTR) Program," *Proc. RERTR 2005*, Boston, Massachusetts (November 6-10, 2005).

^d "Startup Plan for the NRAD Reactor Final Report," PLN-3285 rev. 3, Idaho National Laboratory (August 2010). [This reference is not available for public release.]

^e "Startup Report for the NRAD Reactor," 911195 rev. 0, GA Project 39296, TRIGA Reactor Division of General Atomics (November 4, 2010). [This reference is not available for public release.]

^f "NRAD Safety Analysis Report," DSA-005-NRAD rev. 5, Idaho National Laboratory (April 2, 2009). [This reference is not available for public release.]

^g "NRAD Reactor Fuel Core Conversion," DSA-005-NRAD-ADD-3 rev. 0, Idaho National Laboratory (April 2, 2009). [This reference is not available for public release.]

description,^a and various component design drawings (Appendix F). Significant information and clarification were provided by Tom Maddock, a former staff member at the HFEF facility, and Ken Schreck, the NRAD Reactor Manager throughout the conversion process.

General Atomics provided some information regarding TRIGA reactor fuel and control rods and developed the start-up plan for the LEU conversion of the NRAD.^{b,c} Additional material data were obtained from samples analyzed at independent laboratories.

A criticality benchmark of an annular TRIGA Mark II reactor containing U(20)-Zr-H fuel (no erbium content) has already been evaluated.^d

1.1 Description of the Critical and / or Subcritical Configuration

1.1.1 Overview of Experiment

The initial critical configuration developed during the fuel loading process, which contains only 56 fuel elements, has been evaluated as an acceptable benchmark experiment. The 60-fuel-element operational core configuration of the NRAD LEU TRIGA reactor has also been evaluated as an acceptable benchmark experiment.

Additional critical configurations were recorded during the start-up measurements; the initial critical configuration for the 56-fuel-element core with additional detectors, a second critical configuration for the 60-fuel-element operational core with the regulating rod fully withdrawn and the shim rods partially inserted, four configurations with one of the graphite reflector blocks removed from the core, and multiple critical positions for both core configurations during the positive period measurements (see Section 1.4). These configurations are considered very similar to the second benchmark experiment configuration and therefore were not evaluated as criticality experiments but as worth measurements (see Section 3.4).

1.1.2 Geometry of the Experiment Configuration and Measurement Procedure

The NRAD reactor (Figure 1.1) is a 250 kW TRIGA LEU conversion reactor that is a water-moderated, heterogeneous, solid-fuel, tank-type research reactor. The reactor is composed of fuel in three- and four-element clusters that can be arranged in a variety of lattice patterns, depending on reactivity requirements. Typically, the three-element clusters also include a guide tube in the fourth position, for use as a control rod or irradiation position. The grid plate consists of 36 holes, on a 6-by-6 rectangular pattern, that mate with the end fittings of the fuel cluster assemblies.^e

^a "HFEF/N Neutron Radiography Facility System Design Description," W0170-0004-SA rev. 2, Idaho National Laboratory (June 1, 1978). [This reference is not available for public release.]

^b "Neutron Radiography Reactor Analysis and Support: HEU to LEU Conversion of the NRAD Reactor, Final Report," 911124 rev. 2, GA Project 39296, TRIGA Reactor Division of General Atomics (February 12, 2010). [This reference is not available for public release.]

^c "Neutron Radiography Reactor Analysis and Support: Startup Plan for the NRAD Reactor, Final Report," 911183 rev. 1, GA Project 39296, TRIGA Reactor Division of General Atomics (January 13, 2010). [This reference is not available for public release.]

^d R. Jeraj and M. Ravnik, "TRIGA Mark II Reactor: U(20) – Zirconium Hydride Fuel Rods in Water with Graphite Reflector," Rev. 0 (September 30, 1999), IEU-COMP-THERM-003, *International Handbook of Evaluated Criticality Safety Benchmark Experiments*, NEA/NSC/DOC(95)03, OECD-NEA (2010).

^e "NRAD Reactor Fuel Core Conversion," DSA-005-NRAD-ADD-3 rev. 0, Idaho National Laboratory (April 2, 2009). [This reference is not available for public release.]

The dimensions obtained from most of the references were reported in feet and inches. Where referenced in this report, the original dimensions are then followed by their converted values in units of meters or centimeters, in parenthesis. The number of decimal places in the converted units does not imply additional precision, but preservation of the original measurement.

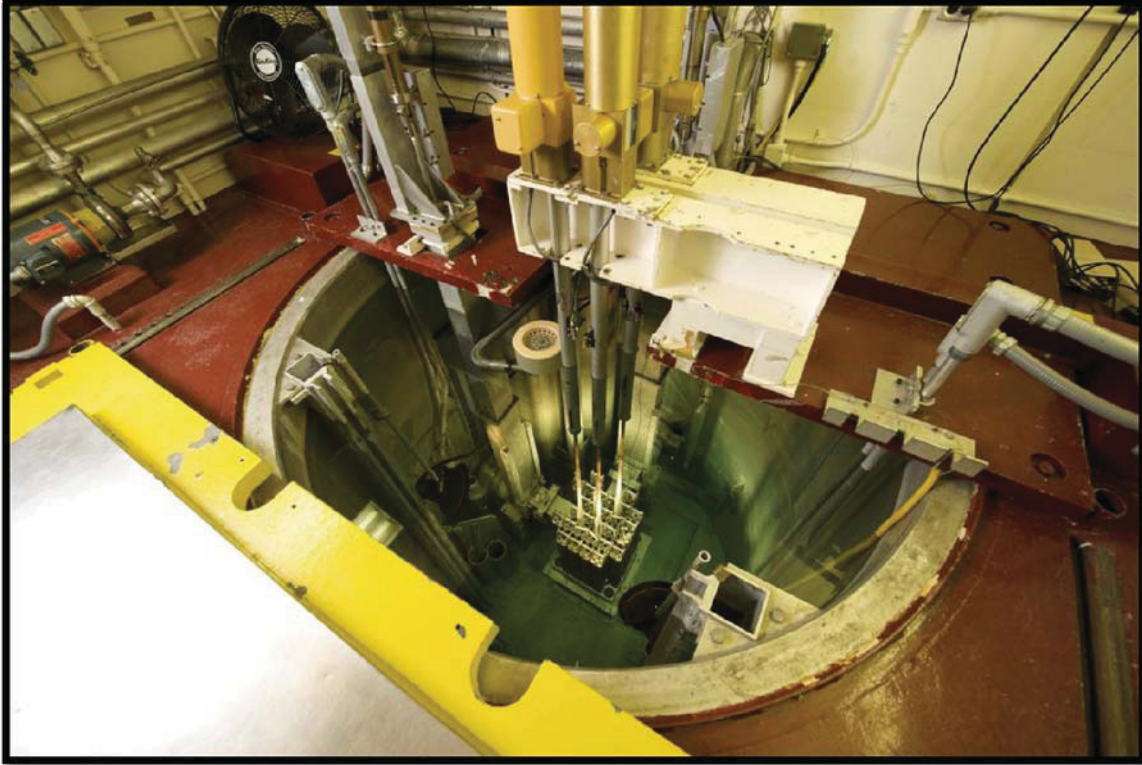

Figure 1.1a. Top-Down View of the NRAD Reactor.

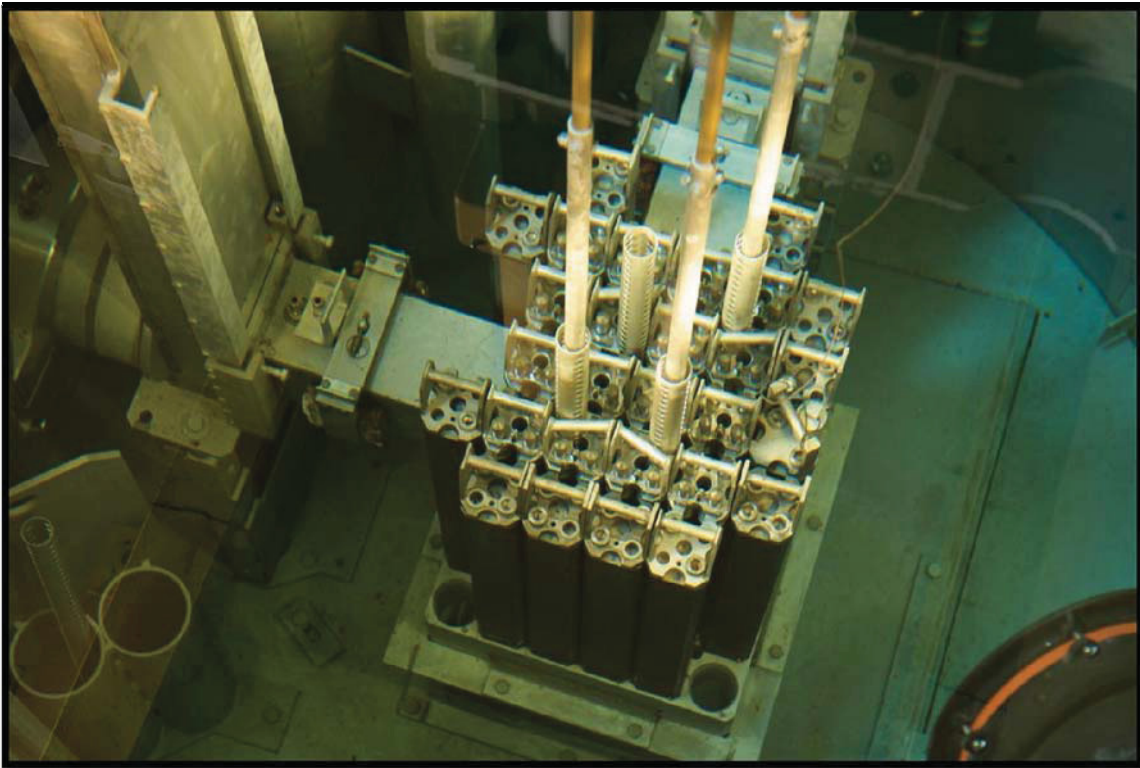

Figure 1.1b. In-Tank View of the NRAD Reactor Core.

1.1.2.1 Facility Description

Site and Facility

The NRAD reactor is located in the basement, below the main hot cell, of the Hot Fuels Examination Facility (HFEF), shown in Figure 1.2, at the Materials and Fuels Complex (MFC) of the Idaho National Laboratory (INL), formerly known as Argonne-West.

The floor area in the reactor room is 11 ft 6 in. (3.5052 m) by 12 ft (3.6576 m) with a height of 16 ft 9 in. (5.1054 m), and is located at the east end of the HFEF cask tunnel. Prior to placement of the reactor tank, the original floor and soil were excavated down to the rock level and then backfilled with concrete to the depth of the original floor.^a

The excavation is approximately 10 ft (3.048 m) deep.

The reactor tank fills most of the room in which it is placed. It is embedded in a massive, reinforced-concrete block that is surrounded on three sides by reinforced-concrete walls. The concrete serves both as a working platform at the top level of the reactor tank and as a biological shield.^b

The reactor tank is surrounded by concrete except around the beam tubes, where additional shielding is required. The concrete around the tank is filled up to the tank top, about 5 ft 6 in. (1.6764 m) from the

^a "HFEF/N Neutron Radiography Facility System Design Description," W0170-0004-SA rev. 2, Idaho National Laboratory (June 1, 1978). [This reference is not available for public release.]

^b "NRAD Safety Analysis Report," DSA-005-NRAD rev. 5, Idaho National Laboratory (April 2, 2009). [This reference is not available for public release.]

ceiling. The North, East, and South walls have a concrete thickness of 2.5, 4, and 5 ft (76.2, 121.92, and 152.4 cm), respectively. The West wall, to a height of 11.5 ft (3.5052 m) was formed by the concrete surrounding the tank. The remaining height of the West wall consists of 2 in. (5.08 cm) thick lead bricks sandwiched between steel plates. Two sections of this shielding wall are fixed at either side with two other sections capable of sliding open to provide access to the reactor room. This opening is 5 ft 3 in. (1.6002 m) wide and 5 ft 6 in. (1.6764 m) high. A fixed ladder provides entry for personnel from the cask tunnel.^a

The ceiling is made of 42 in. (106.68 cm) thick reinforced high-density concrete.^b

Additional shielding was provided by embedding steel plates, borated polyethylene, and lead bricks within the concrete shielding. The maximum thickness of the West shield is 12 in. (30.48 cm) steel plus 1 in. (2.54 cm) polyethylene. A 6 in. (15.24 cm) thick steel slab with 1 in. (2.54 cm) thick borated polyethylene slab is placed to the north of the reactor around the north beam tube penetration. A 4 in. (10.16 cm) thick layer of lead bricks is embedded in a rectangular box to the West side of the top of the reactor tank.^a

A plan and elevation view of the NRAD is shown in Figures 1.3 and 1.4, respectively. The placement of the fuel handling cask is shown in these two figures; however, the cask is not placed in the tank, except when fuel loading and unloading tasks are being performed.

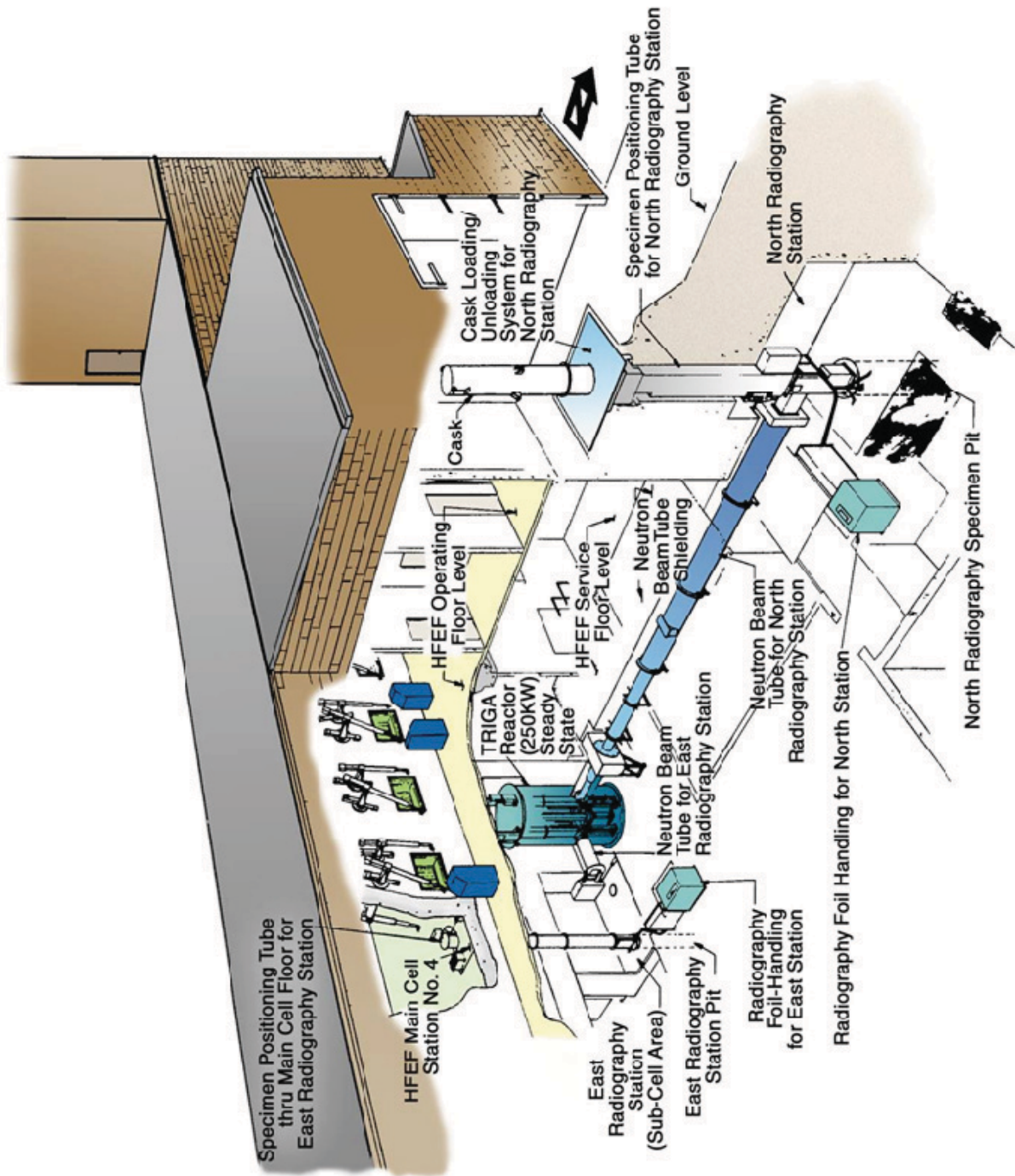
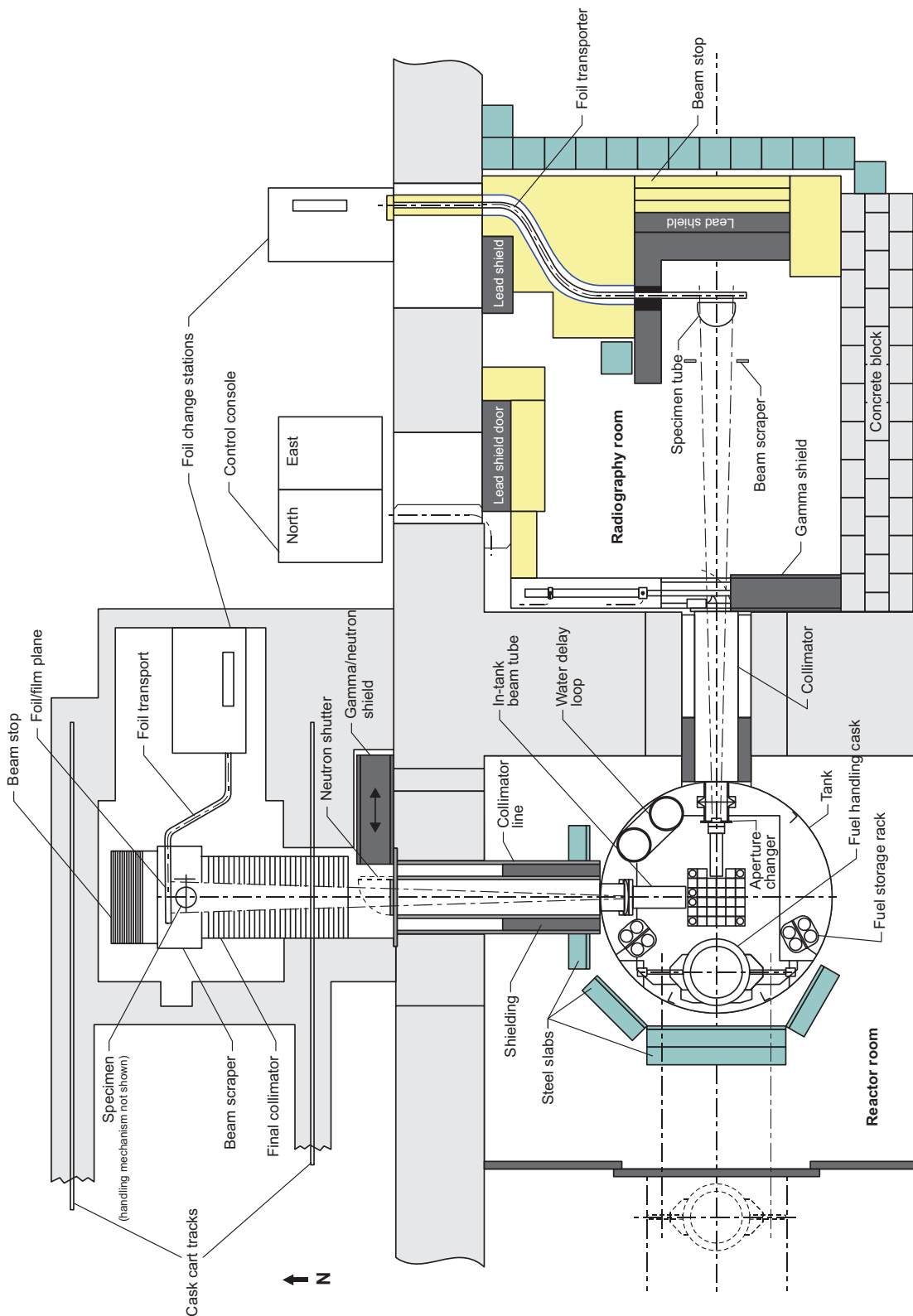

Figure 1.2. Hot Fuels Examination Facility.



10-GA0002-04-1

Figure 1.3. Plan View of the NRAD Facility.^a

^a “NRAD Safety Analysis Report,” DSA-005-NRAD rev. 5, Idaho National Laboratory (April 2, 2009). [This reference is not available for public release.]

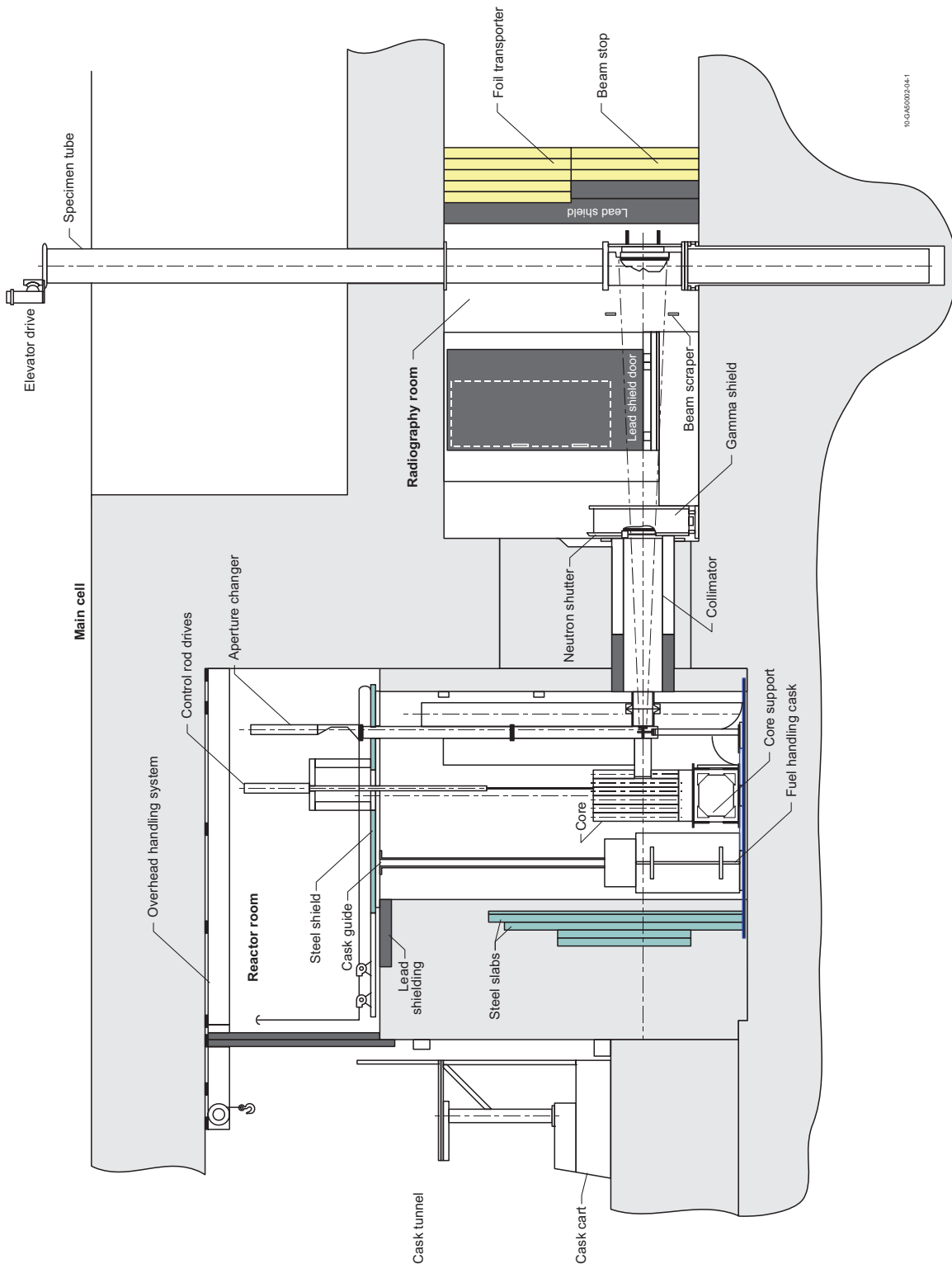

Figure 1.4. Elevation View of the NRAD Facility.^a

^a “NRAD Safety Analysis Report,” DSA-005-NRAD rev. 5, Idaho National Laboratory (April 2, 2009). [This reference is not available for public release.]

Reactor Containment

A reactor tank houses the reactor core and contains the primary coolant. The tank is a welded construction of aluminum 6061-T6 that is 6.5 ft (1.9812 m) in diameter, 11.5 ft (3.5052 m) high, has 0.25 in. (0.635 cm) thick walls, and has a bottom that is 0.5 in. (1.27 cm) thick. It is open at the top.^a

Two collars are butted to the outside surface of the tank to mate with beam-tube liners and two pipe stubs are welded to the inside surface to mate with nozzles. The only penetration in the tank wall is located near the top of the tank for the water-overflow pipe. Delay loops are provided inside the tank to allow ¹⁶N contained in the water to decay prior to entering the primary coolant system.^b

A diagram of the NRAD cross-section in the reactor tank is shown in Figure 1.5.

A reactor top shield serves as a working platform and is made of 2 in. (5.08 cm) thick steel. It is comprised of three sections: one that is fixed and supports the control-rod drives, one that is mounted on rollers and can be moved to access the reactor tank, and one that can be moved, if required, by an overhead handling system (see Figure 1.1a). These slabs are large enough that they cannot be dropped into the reactor core during handling.^c

^a “NRAD Reactor Fuel Core Conversion,” DSA-005-NRAD-ADD-3 rev. 0, Idaho National Laboratory (April 2, 2009). [This reference is not available for public release.]

^b “HFEF/N Neutron Radiography Facility System Design Description,” W0170-0004-SA rev. 2, Idaho National Laboratory (June 1, 1978). [This reference is not available for public release.]

^c “NRAD Safety Analysis Report,” DSA-005-NRAD rev. 5, Idaho National Laboratory (April 2, 2009). [This reference is not available for public release.]

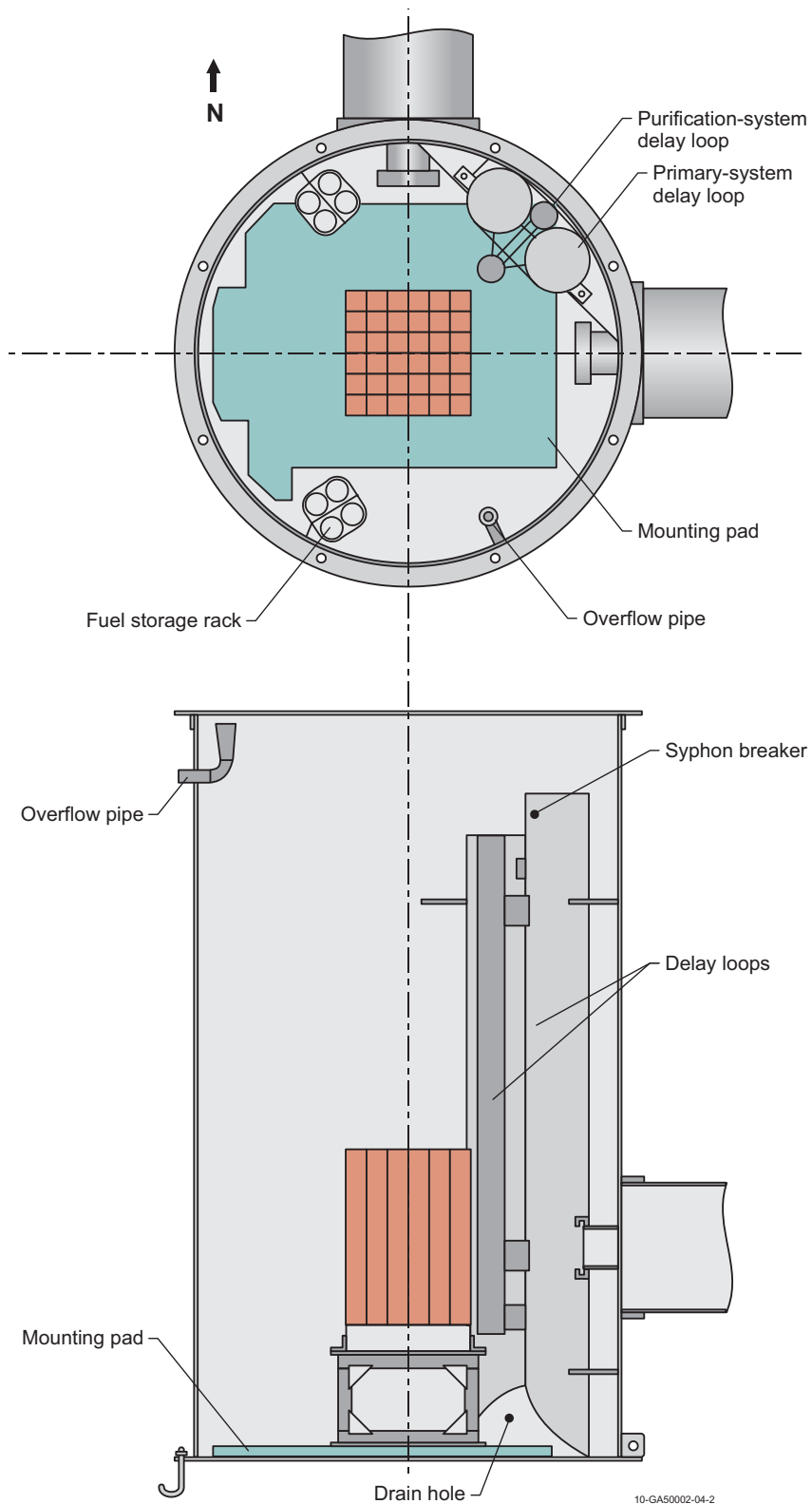

Figure 1.5. NRAD Tank.

Non-Nuclear Components

A 2 in. (5.08 cm) diameter overflow pipe maintains the maximum water level 2 in. (5.08 cm) below the top of the tank. The two 24 in. (60.96 cm) diameter collars butted to the outside of the tank surface are designed to provide support and a seal for the beam-tube liners. The two 9 in. (22.86 cm) diameter pipe stubs, which are aligned with the collars, are welded inside the tank for mating with nozzles. The nozzles extend between the reactor tank wall and the core skirt to exclude water from the path of the beam line.^a

Attached to the inner tank wall is a primary coolant system water delay loop. The holdup tank is shaped like an upright “U” and is made of 12 in. (30.48 cm) diameter aluminum pipe with a total length of 20 ft (6.096 m) and a holding capacity of 120 gal. (~454.25 L).

Moderator/Coolant

The reactor core is cooled via natural circulation of water within the open reactor tank. Heat is removed from the reactor tank by forced circulation induced by a primary water system through a water-to-water heat exchanger. The secondary side of the heat exchanger is then cooled by the HFEF cooling water system, which is cooled by the HFEF cooling tower.^b

The tank water also serves as a biological shield for the reactor and is approximately 10 ft (3.048 m) deep.

1.1.2.2 Reactor Core

The NRAD LEU operational core configuration contains 60 fuel elements, two water-followed shim control rods, and one water-followed regulating rod (Figure 1.6). A water hole is provided as an experimental irradiation position via the use of an empty control rod guide tube placed near the center of the core. The NRAD reactor uses graphite neutron reflector assemblies located along the periphery grid plate locations. The number and position of fuel-element and reflector assemblies can be varied to adjust core reactivity.

Core positions are designated by a grid reference system, as labeled in Figure 1.6. The location of individual elements within a grid position is defined in Figure 1.7. Positions in the grid are identified with a letter-number pair. For example, the location of the in-core irradiation assembly is identified as C-4. The location of a specific position within an assembly is further designated by its location with respect to the center of the assembly. The location of the in-core irradiation position is identified as C-4 SW.

The circular items labeled “G” through “N”, in Figure 1.6, are in-pool storage locations.

^a “HFEF/N Neutron Radiography Facility System Design Description,” W0170-0004-SA rev. 2, Idaho National Laboratory (June 1, 1978). [This reference is not available for public release.]

^b “NRAD Reactor Fuel Core Conversion,” DSA-005-NRAD-ADD-3 rev. 0, Idaho National Laboratory (April 2, 2009). [This reference is not available for public release.]

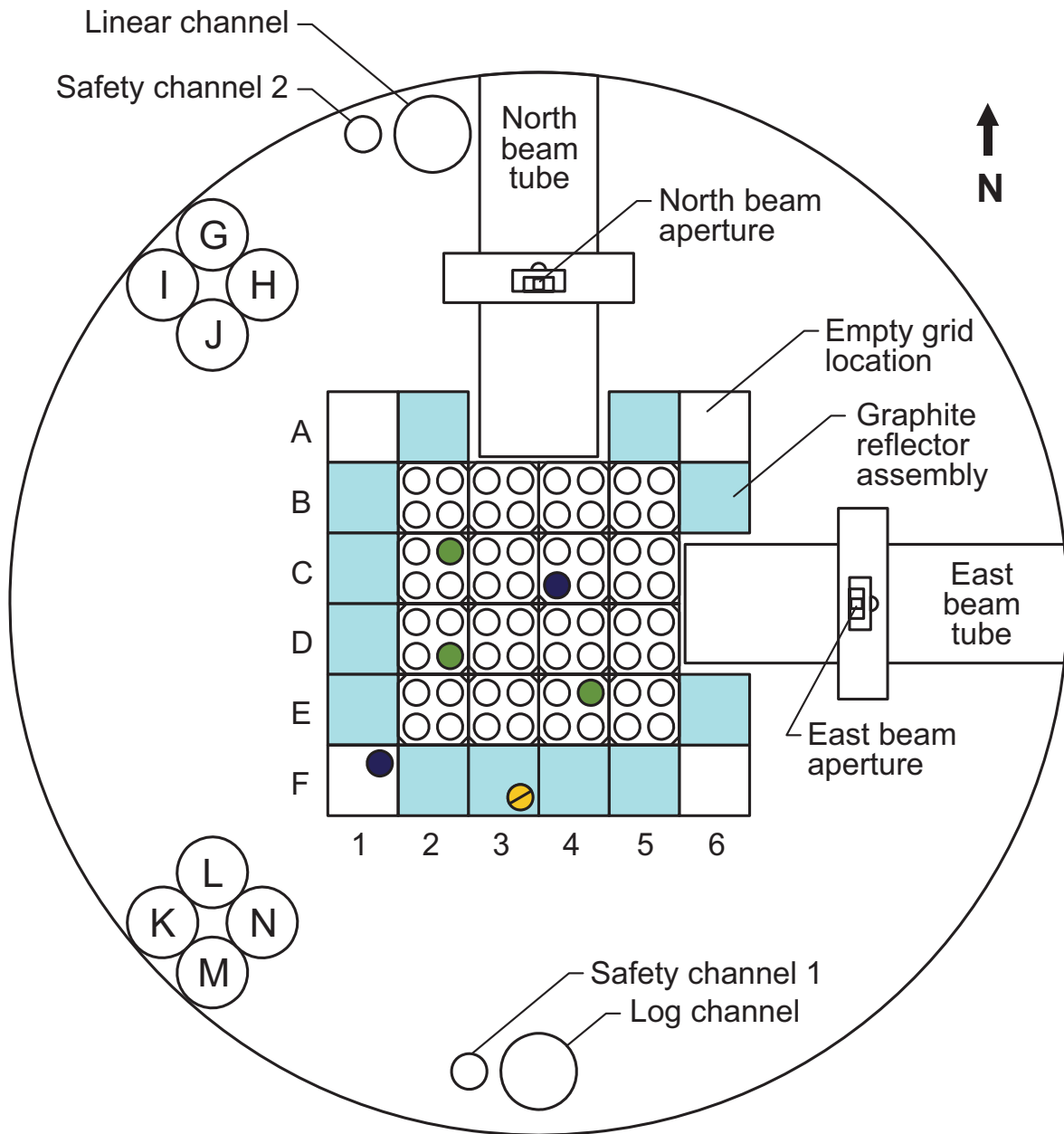

Fuel cluster assembly

Standard fuel element

- Control rod
- Neutron source (AmBe)
- Irradiation positions

10-GA50002-04-3

Figure 1.6. NRAD LEU Core Configuration.^a

^a "NRAD Reactor Fuel Core Conversion," DSA-005-NRAD-ADD-3 rev. 0, Idaho National Laboratory (April 2, 2009). [This reference is not available for public release.]

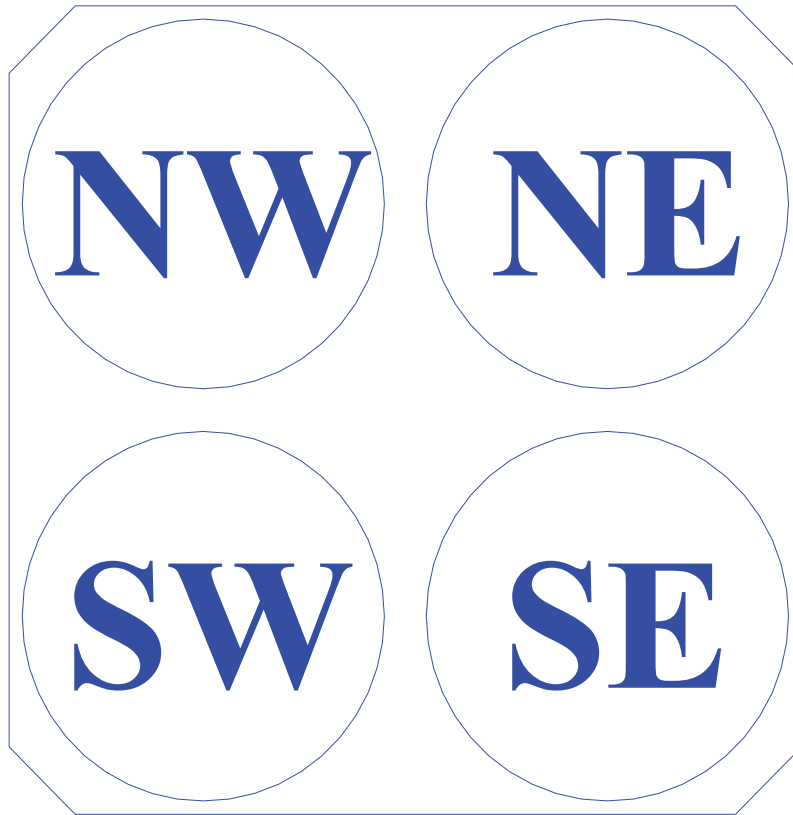

Figure 1.7. Notation for Fuel Element Cluster Position.^a

^a “NRAD Reactor Fuel Core Conversion,” DSA-005-NRAD-ADD-3 rev. 0, Idaho National Laboratory (April 2, 2009). [This reference is not available for public release.]

Core Support Structure

A 1 in. (2.54 cm) thick aluminum mounting pad (Figures 1.5 and 1.9) is welded to the inside surface of the tank bottom.^a

A welded aluminum core support structure (Figure 1.8), which sits below the grid plate, supports the reactor core approximately 16.5 in. (41.91 cm) above the bottom of the reactor tank (Figure 1.9). It is bolted to the mounting pad of the reactor tank in eight places.^b

Grid Plate Assembly

The fuel clusters are supported by a 5 in. (12.7 cm) thick grid plate composed of aluminum 1100 forgings (Figure 1.10). The grid plate has 36 holes placed in a 6×6 rectangular pitch lattice for holding the fuel cluster and reflector assemblies.^a

The grid plate assembly is bolted to the support structure (Figure 1.9).

The nominal spacing between cluster assemblies in the grid plate is shown in Figure 1.11. There is more space between the rod cluster assemblies in the East-West direction than in the North-South direction.^a The original PRNC grid plate was designed to use Materials Testing Reactor (MTR)-type uranium-aluminum plate fuel. The NRAD reactor is a conversion reactor, where the original plate-type fuel bundles were replaced by TRIGA fuel cluster assemblies designed by General Atomics while still at PRNC. The NRAD reactor is one of thirteen conversion reactors.^c

Core positions are designated by a grid reference system, as labeled in Figure 1.6. The location of individual elements within a grid position is defined in Figure 1.7.

Each cluster location utilizes a dowel pin to insure proper cluster orientation. Each dowel pin is approximately 0.250 in. (0.635 cm) in diameter and 1.000 in. (2.54 cm) in length. There are additional holes in the grid plate that allow for water flow and grid-plate cooling.^b

^a “HFEEF/N Neutron Radiography Facility System Design Description,” W0170-0004-SA rev. 2, Idaho National Laboratory (June 1, 1978). [This reference is not available for public release.]

^b “NRAD Reactor Fuel Core Conversion,” DSA-005-NRAD-ADD-3 rev. 0, Idaho National Laboratory (April 2, 2009). [This reference is not available for public release.]

^c R. E. Smith, “TRIGA Fuel Summary Report,” ICP/INT-05-817, Idaho Cleanup Project, Idaho National Laboratory (March 2005). [This reference is not available for public release.]

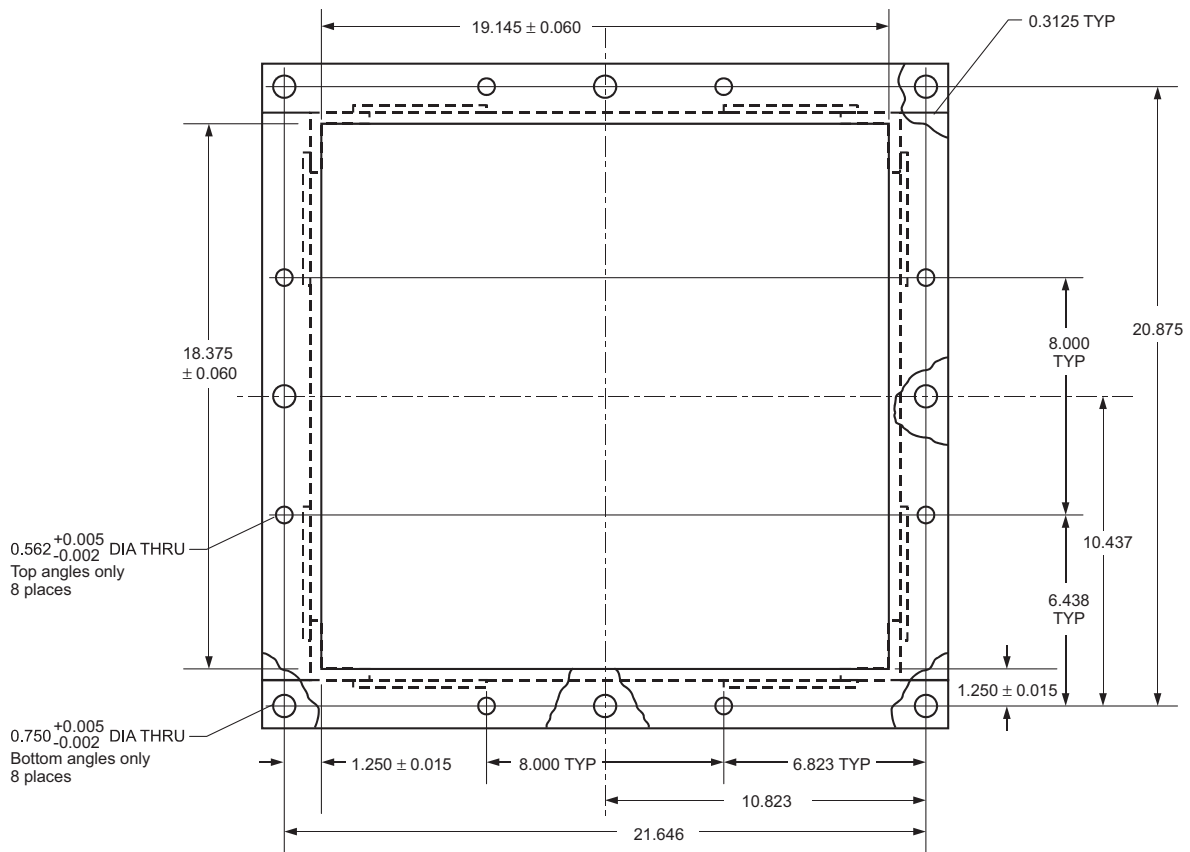

Top View

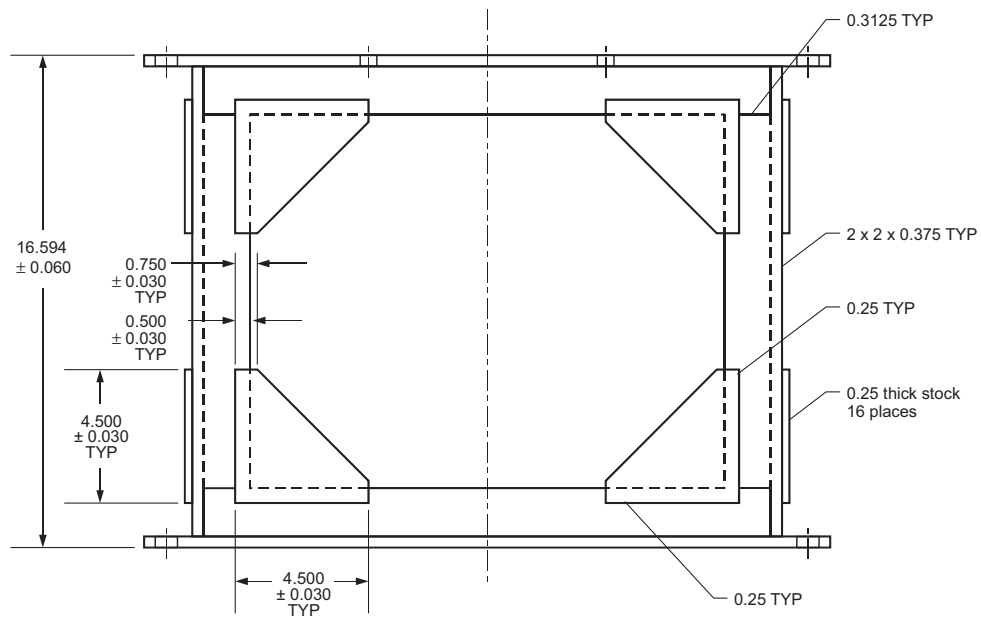

Dimensions in inches

Side View

09-GA50001-152-3

Figure 1.8. Aluminum Core Support Structure.

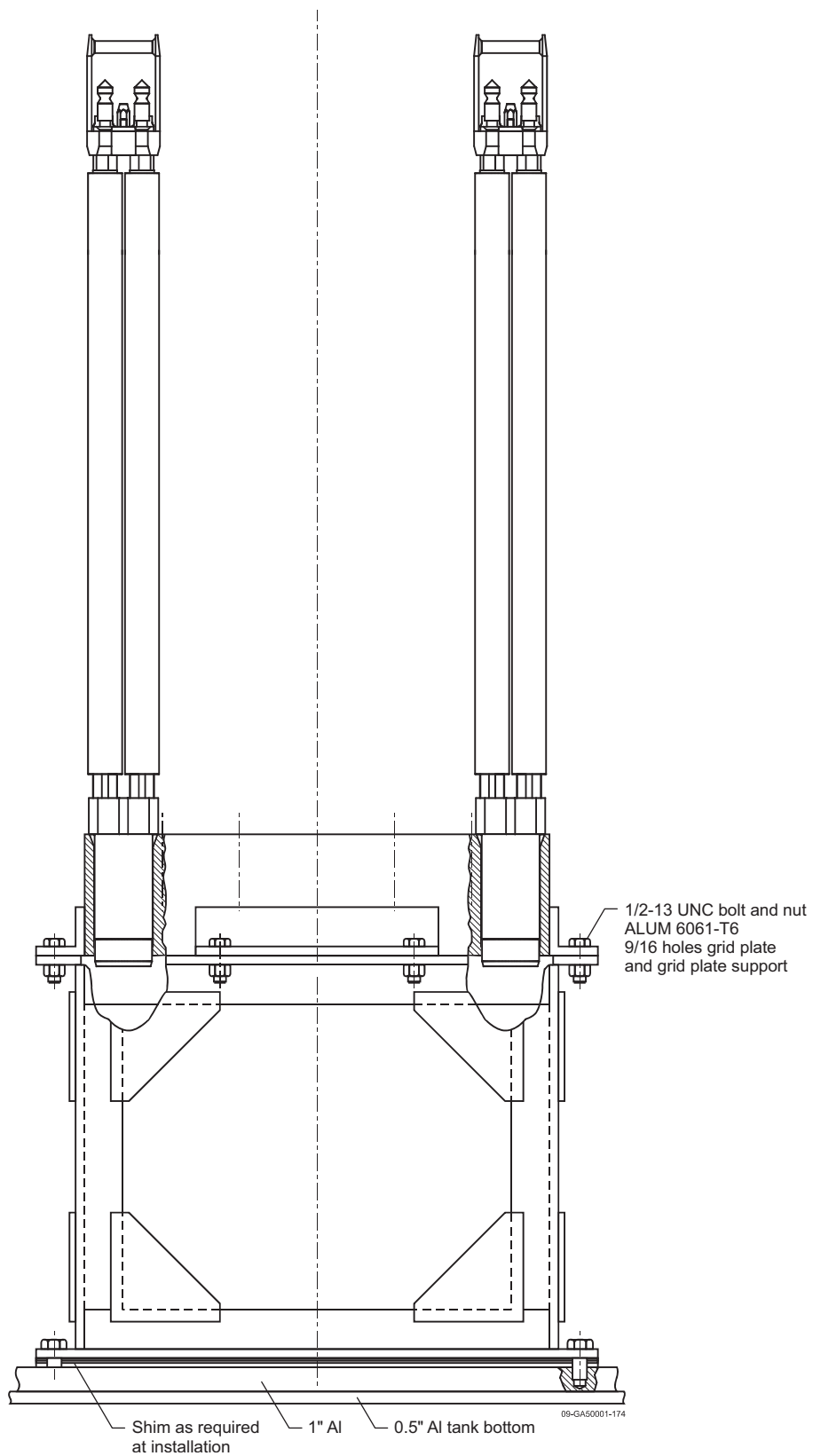

Figure 1.9. Schematic of Core Support Assembly.

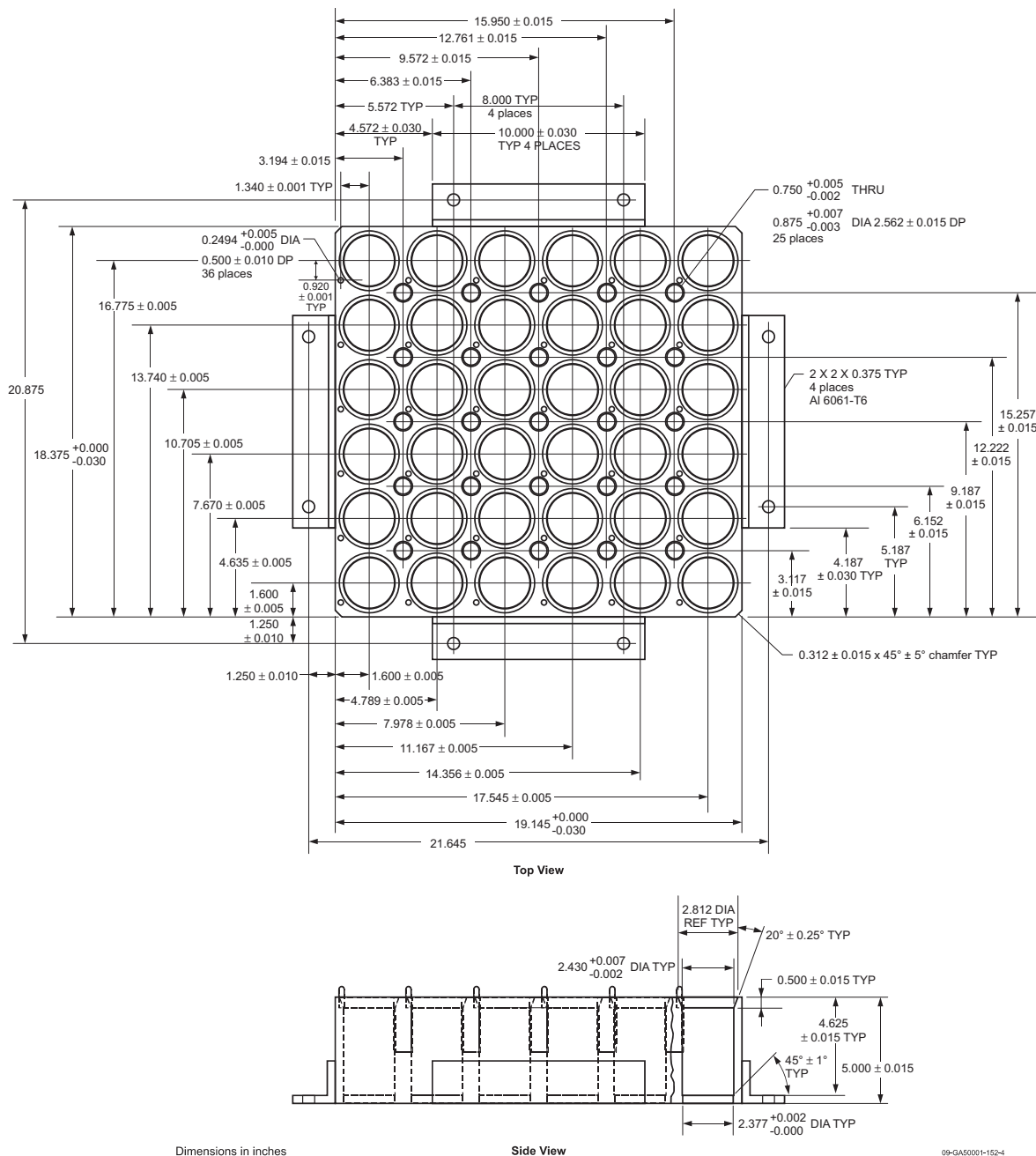
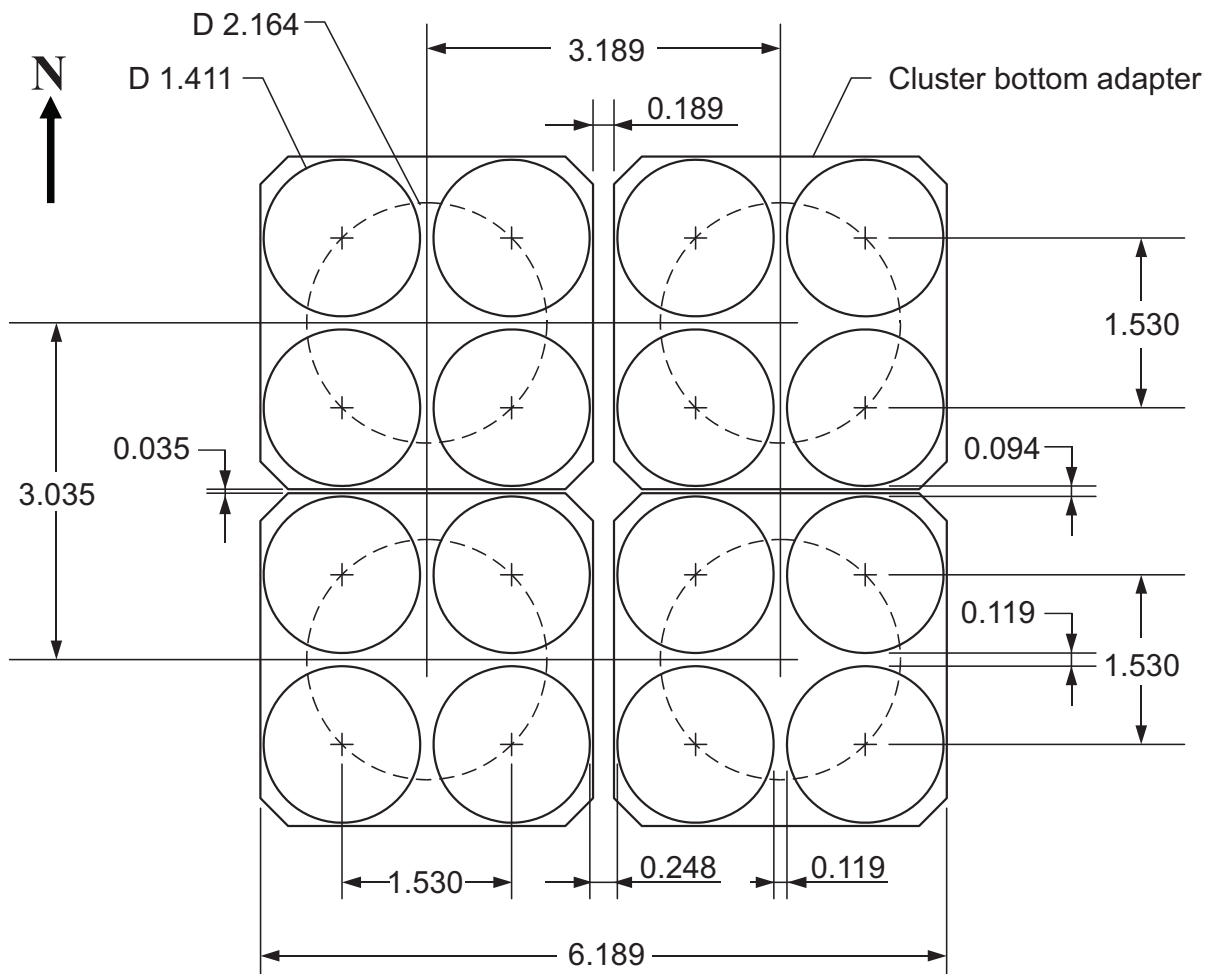

Figure 1.10. Grid Plate Assembly.



Dimensions in inches

09-GA50001-182

Figure 1.11. Nominal Cluster and Fuel Element Spacing.^a

^a "NRAD Reactor Fuel Core Conversion," DSA-005-NRAD-ADD-3 rev. 0, Idaho National Laboratory (April 2, 2009). [This reference is not available for public release.]

Fuel Cluster Assembly

Conversion cluster assemblies contain three or four TRIGA fuel elements. The three-element variation uses the fourth position to accommodate a control rod or a sample irradiation tube.^a

Fuel elements are contained within a four-element fuel cluster assembly (Figures 1.12 and 1.13). As depicted in Figure 1.13, the assembly consists of four fuel elements contained within a bottom cluster fitting assembly (Figure 1.14) and a top handle assembly (Figure 1.15). The assembly was designed to fit TRIGA fuel into the conversion reactor grid format. The top handle assembly is comprised of a locking bolt (Figure 1.16), handle with support plate (Figure 1.17), and locking plate (Figure 1.18). The top and bottom end adapters are attached to the fuel elements to hold the clusters together.

A three-element cluster assembly with a guide tube (Figure 1.35) is shown in Figures 1.19 and 1.20. These cluster assemblies (located in grid positions C-2, C-4, D-2, and E-4) allow for the placement and use of either control rods or water-filled sample-irradiation positions within the core. The three-fuel-element top handle assemblies (Figure 1.21) are comprised of special top fittings (Figure 1.22) and locking plates (Figure 1.23) that were designed to accommodate the guide tube. The same bottom adapter (Figure 1.14) and locking bolt (Figure 1.16) used in the four-element cluster assembly are used to complete the three-element cluster assemblies.

A threaded insert (Figure 1.15) is also used in the top assembly. It has a diameter of 0.25 in. (0.635 cm) and a length of 1.0 in. (2.54 cm).

^a R. E. Smith, "TRIGA Fuel Summary Report," ICP/INT-05-817, Idaho Cleanup Project, Idaho National Laboratory (March 2005). [This reference is not available for public release.]

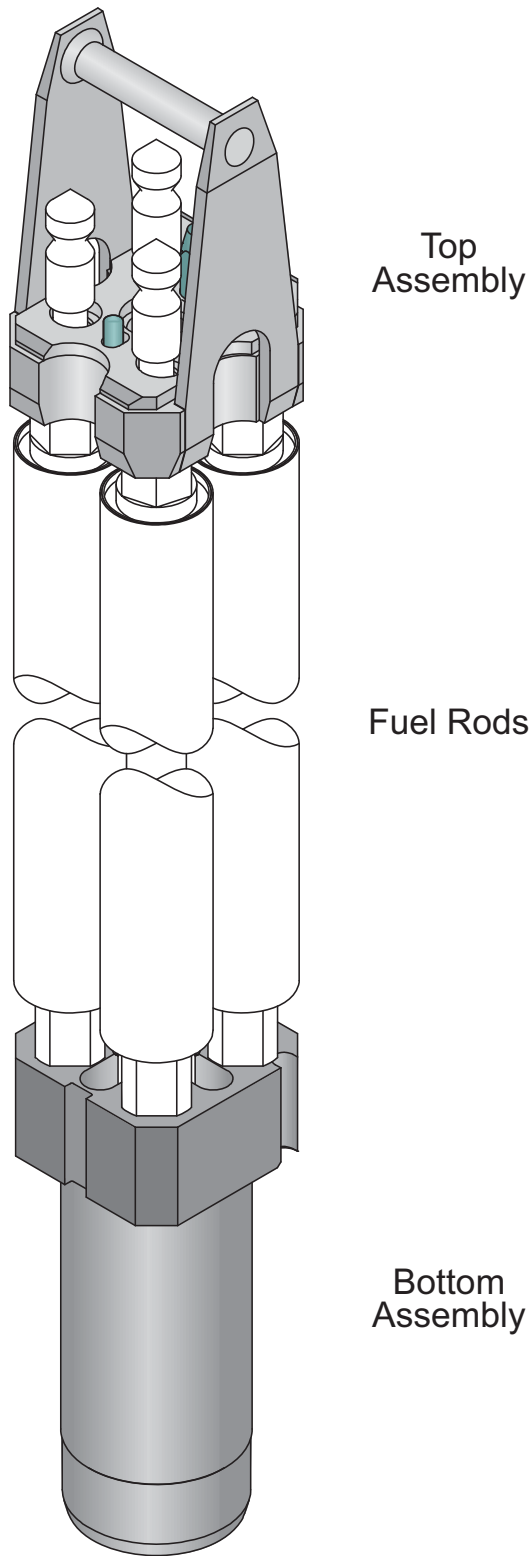

10-GA50002-74-2

Figure 1.12. Four Fuel Element Cluster Assembly.

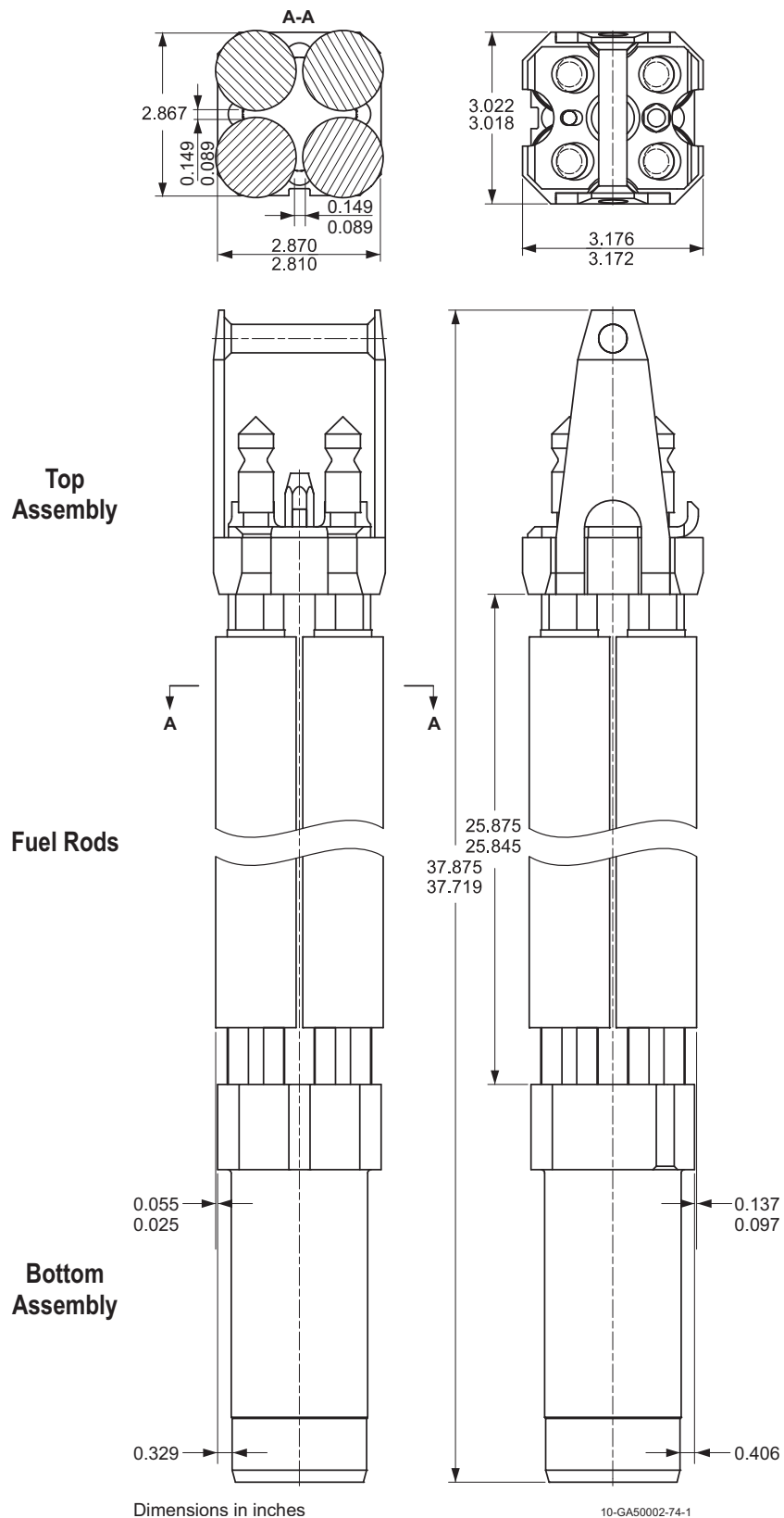

Figure 1.13. Four Fuel Element Cluster Assembly.

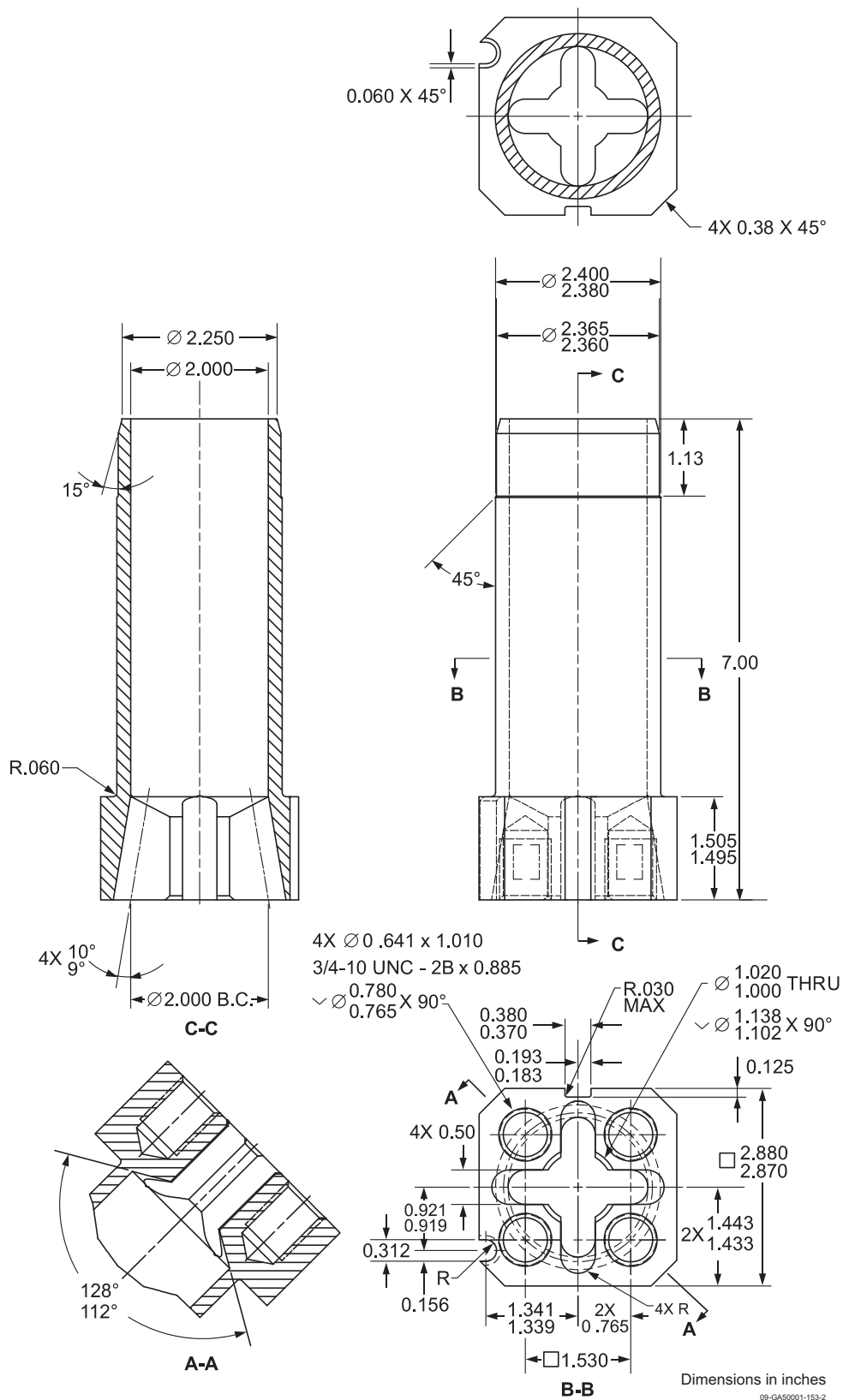

Figure 1.14. Bottom Cluster Fitting Assembly.

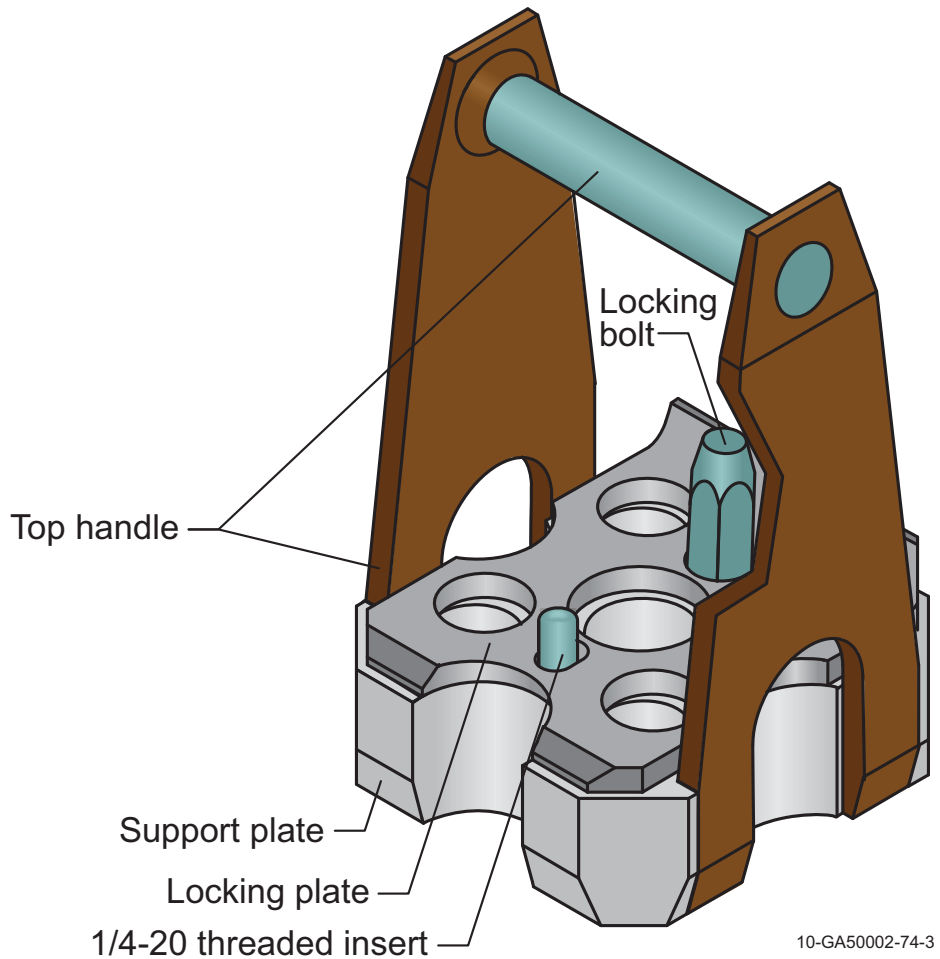
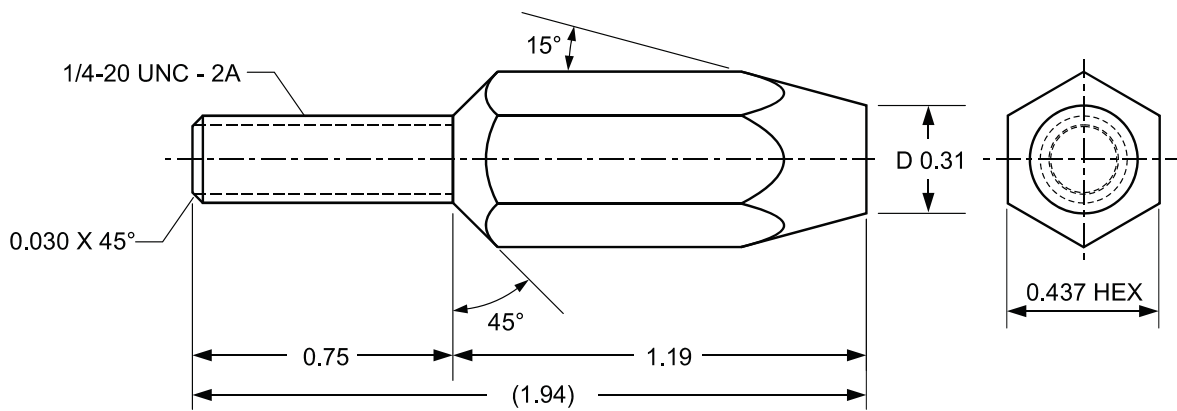

Figure 1.15. Top Handle Assembly for Four Element Cluster Assembly.



Dimensions in inches

09-GA50001-152-1

Figure 1.16. Locking Bolt for Top Handle Assembly.

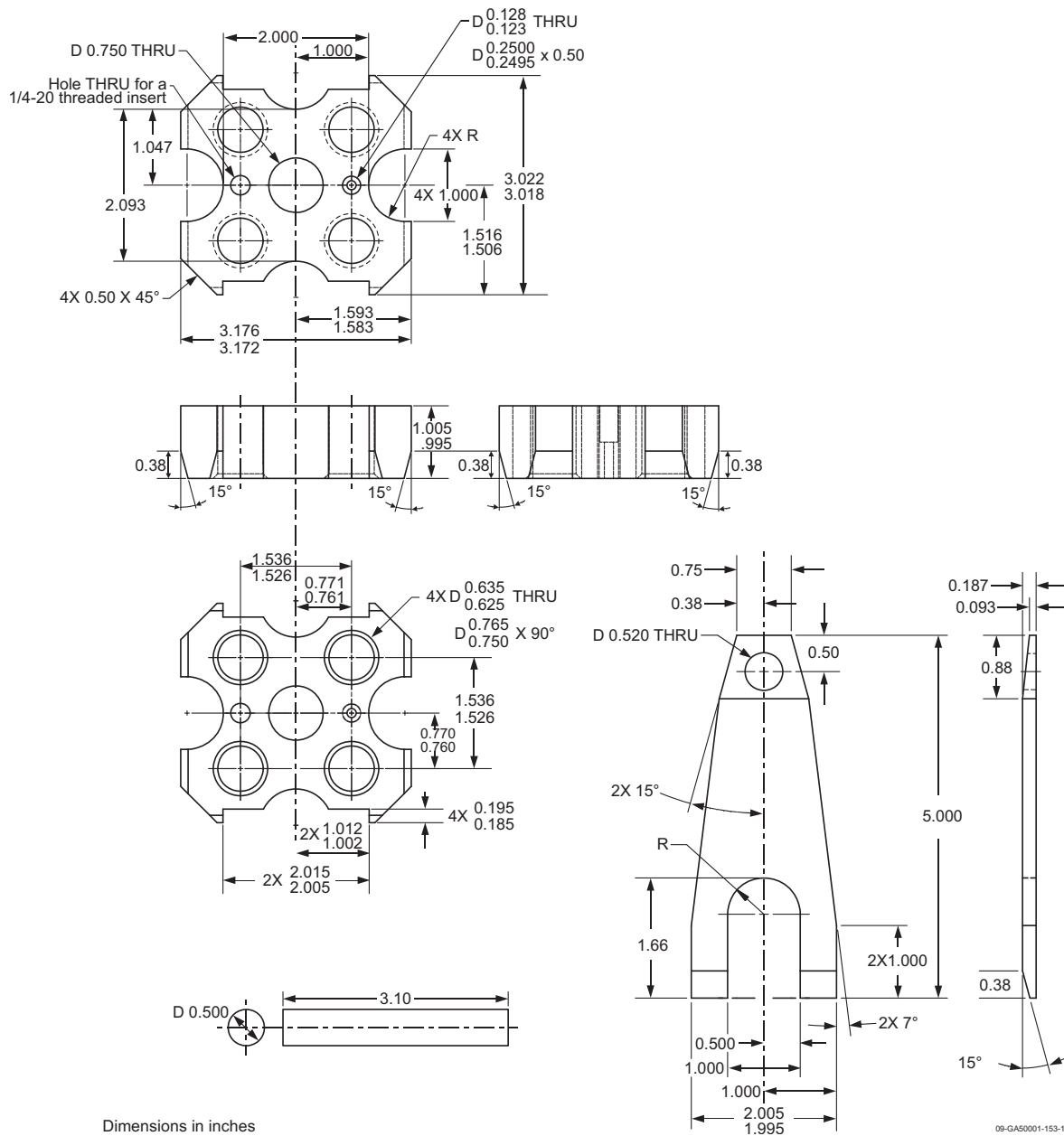
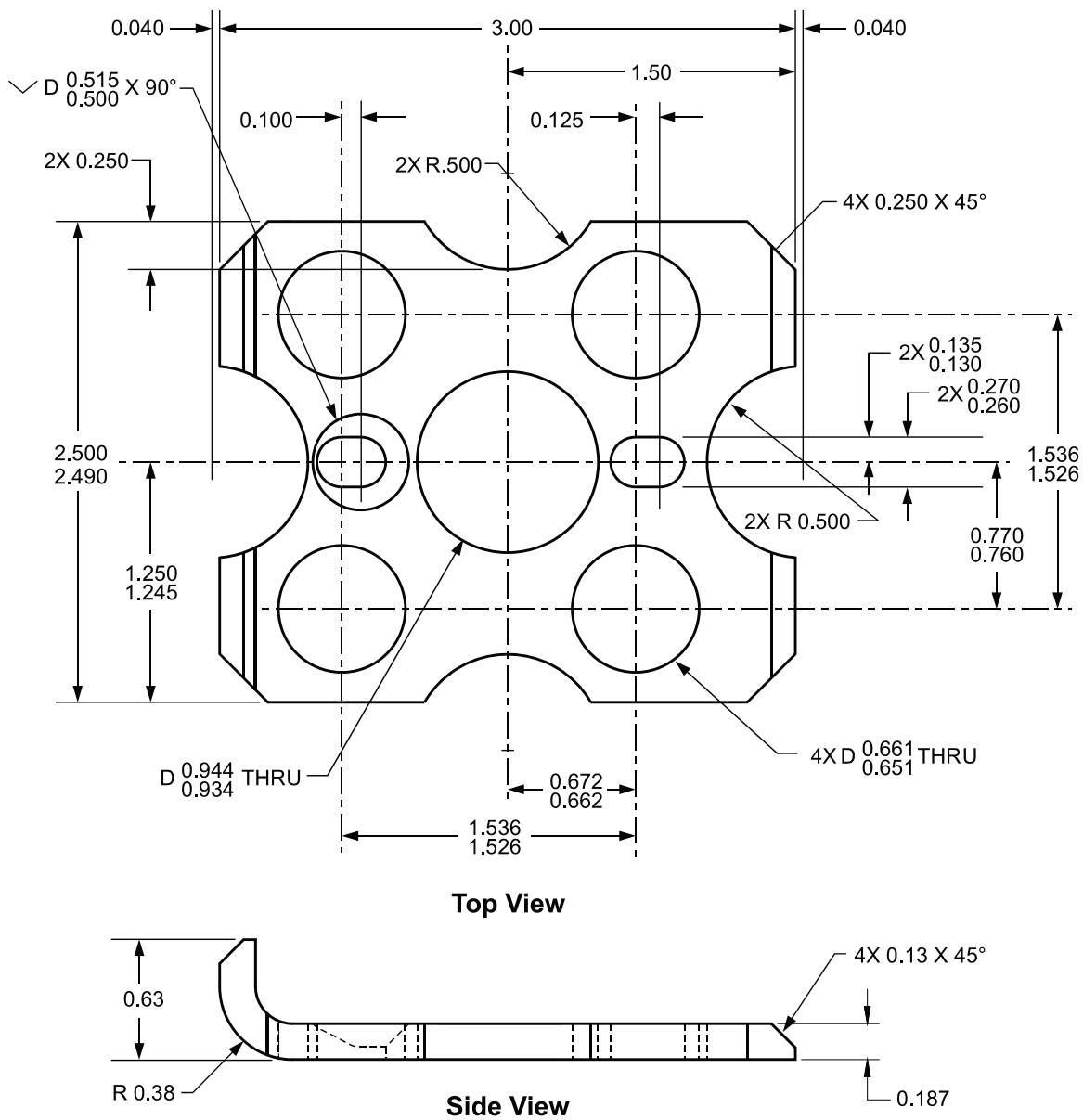

Figure 1.17. Top Handle with Support Plate for Four Element Cluster Assembly.



Dimensions in inches

09-GA50001-152-2

Figure 1.18. Locking Plate for Four Element Cluster Assembly.

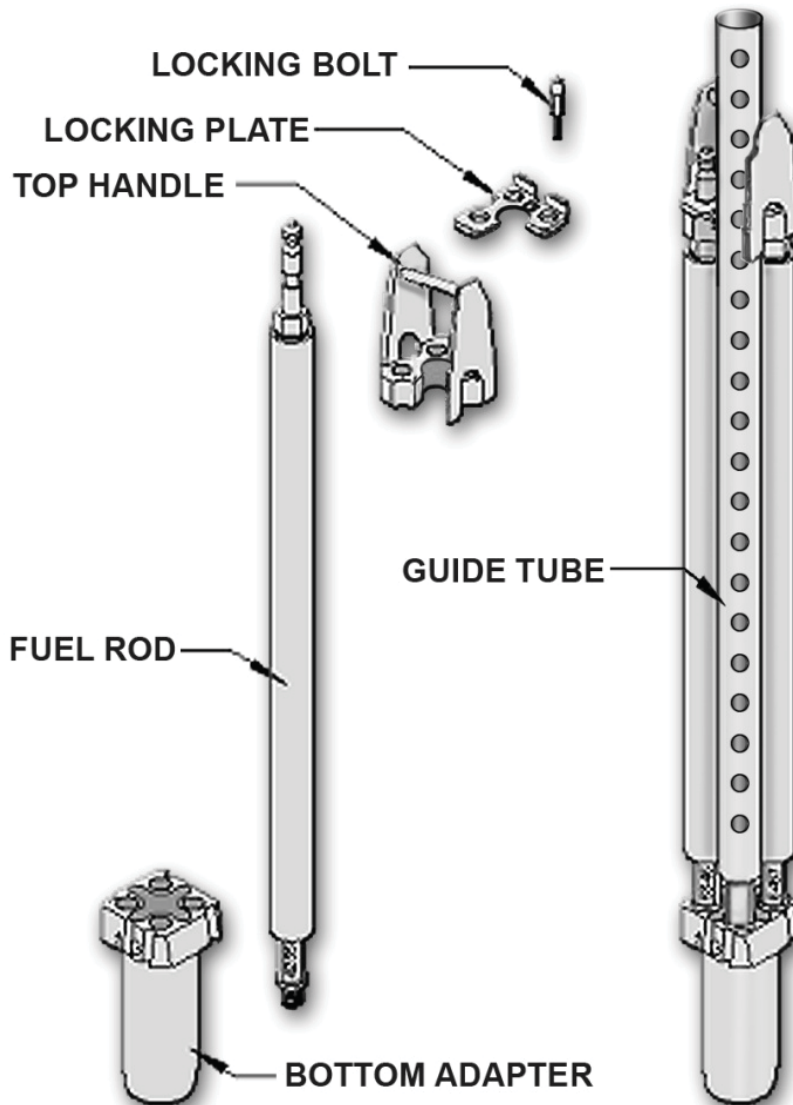

Figure 1.19. Three Fuel Element Cluster Assembly.^a
(The guide tube is utilized either to guide one of three control rods or as a sample irradiation position.)

^a "NRAD Reactor Fuel Core Conversion," DSA-005-NRAD-ADD-3 rev. 0, Idaho National Laboratory (April 2, 2009). [This reference is not available for public release.]

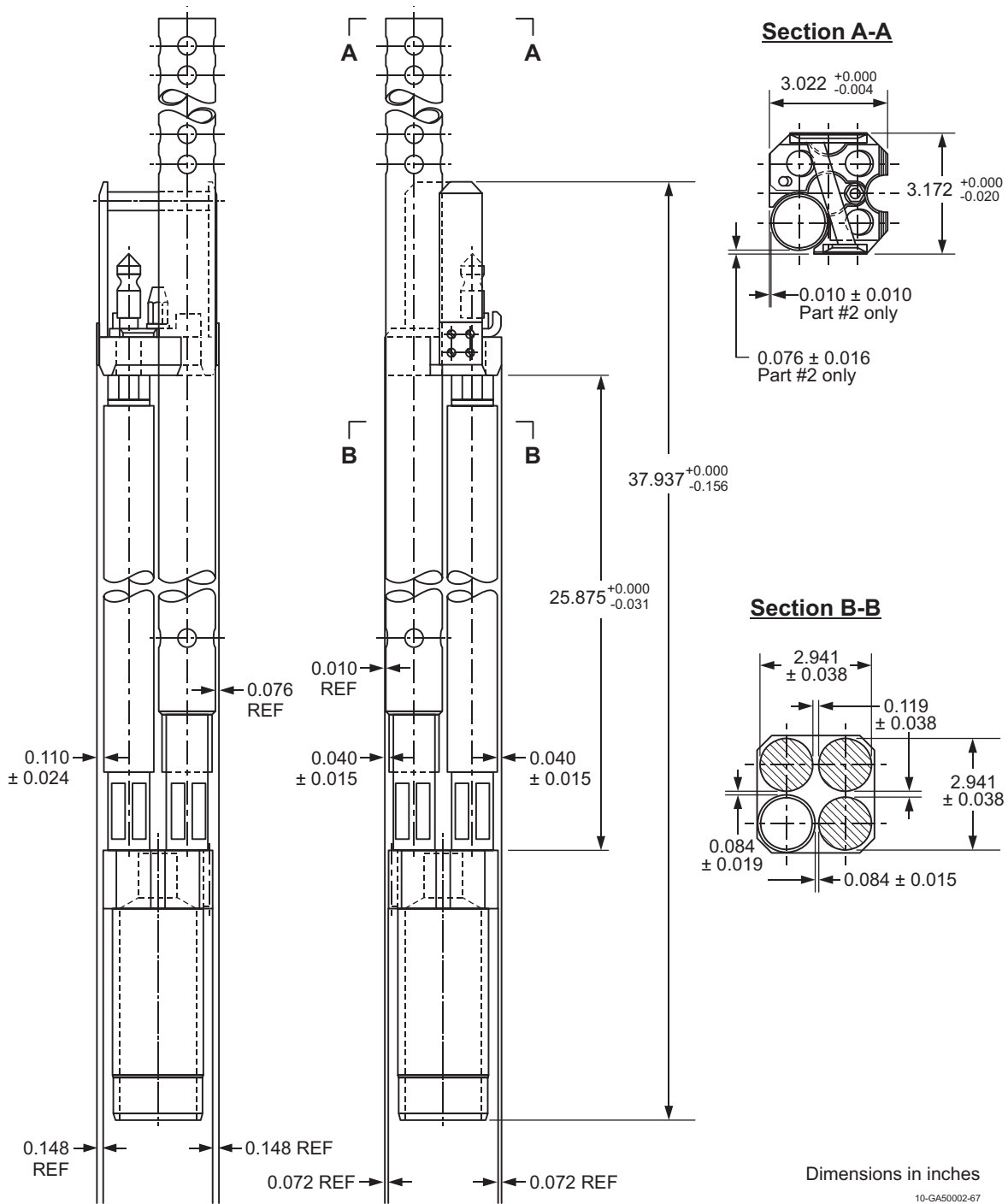

Figure 1.20. Three Fuel Element Cluster Assembly.

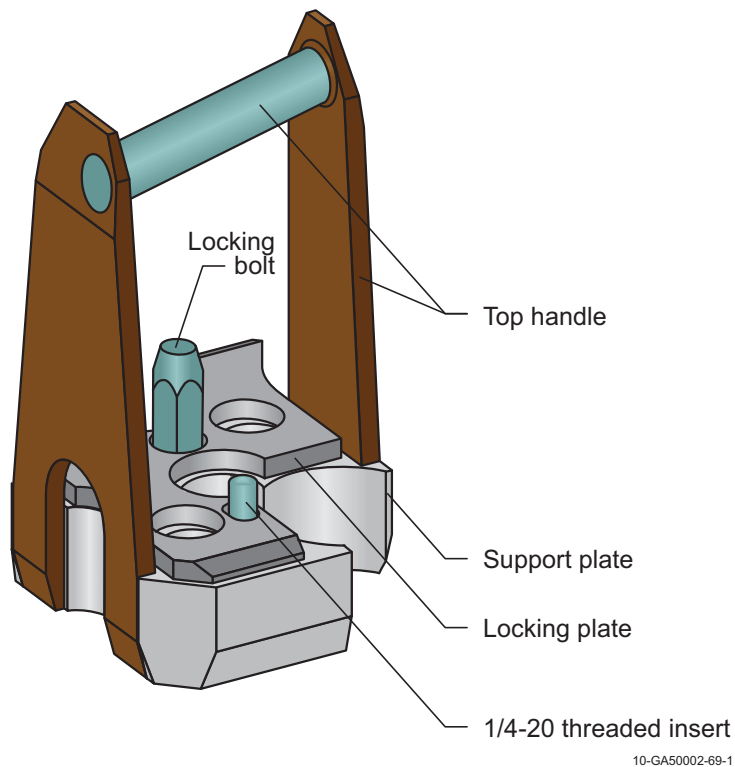

Figure 1.21a. Top Handle Assembly for C2, C4, and E4 Three Element Cluster Assembly.

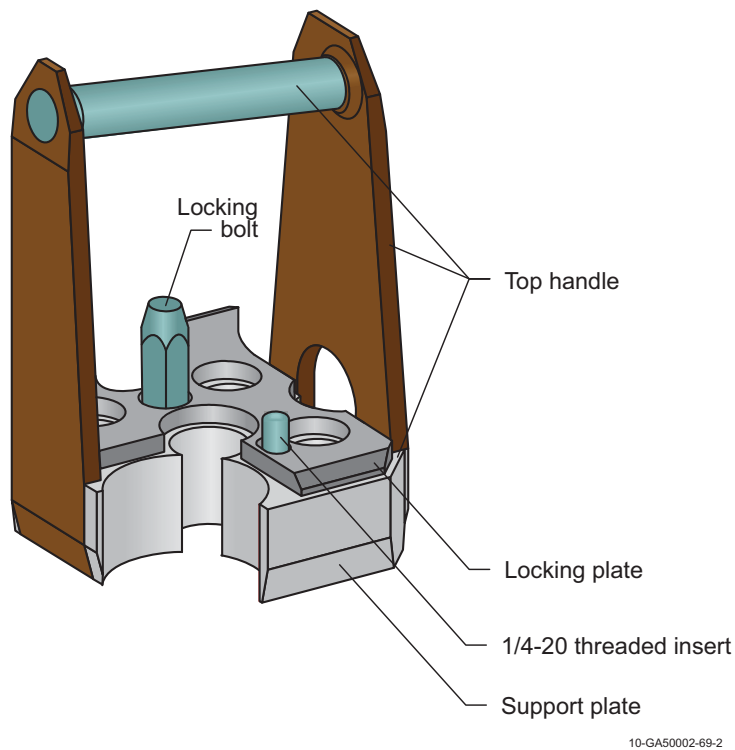
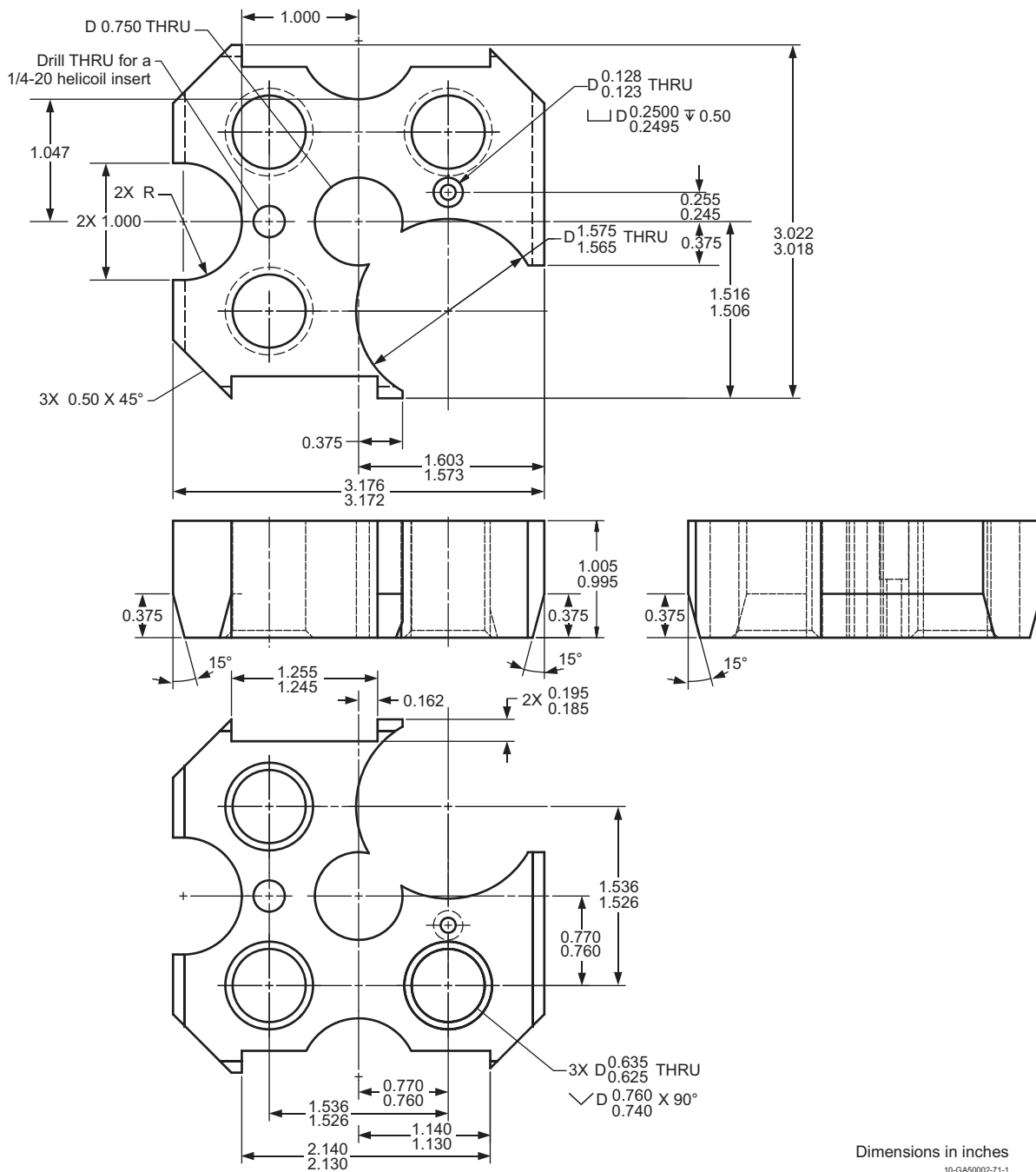

Figure 1.21b. Top Handle Assembly for D2 Three Element Cluster Assembly.



Dimensions in inches
10-GA50002-71-1

Figure 1.22a. Support Plate for C2, C4, and E4 Three Element Cluster Assembly.

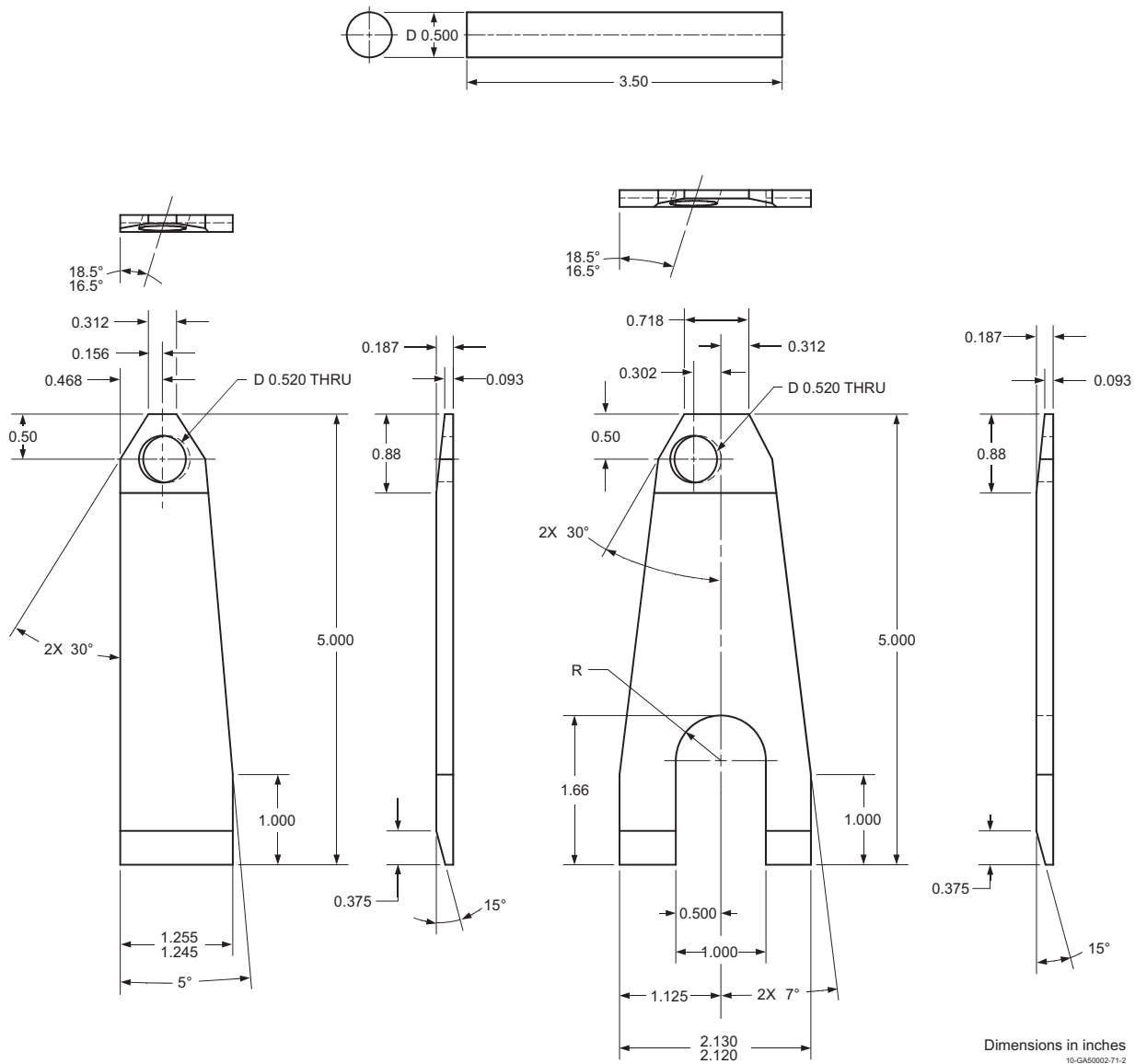

Figure 1.22b. Top Handle for C2, C4, and E4 Three Element Cluster Assembly.

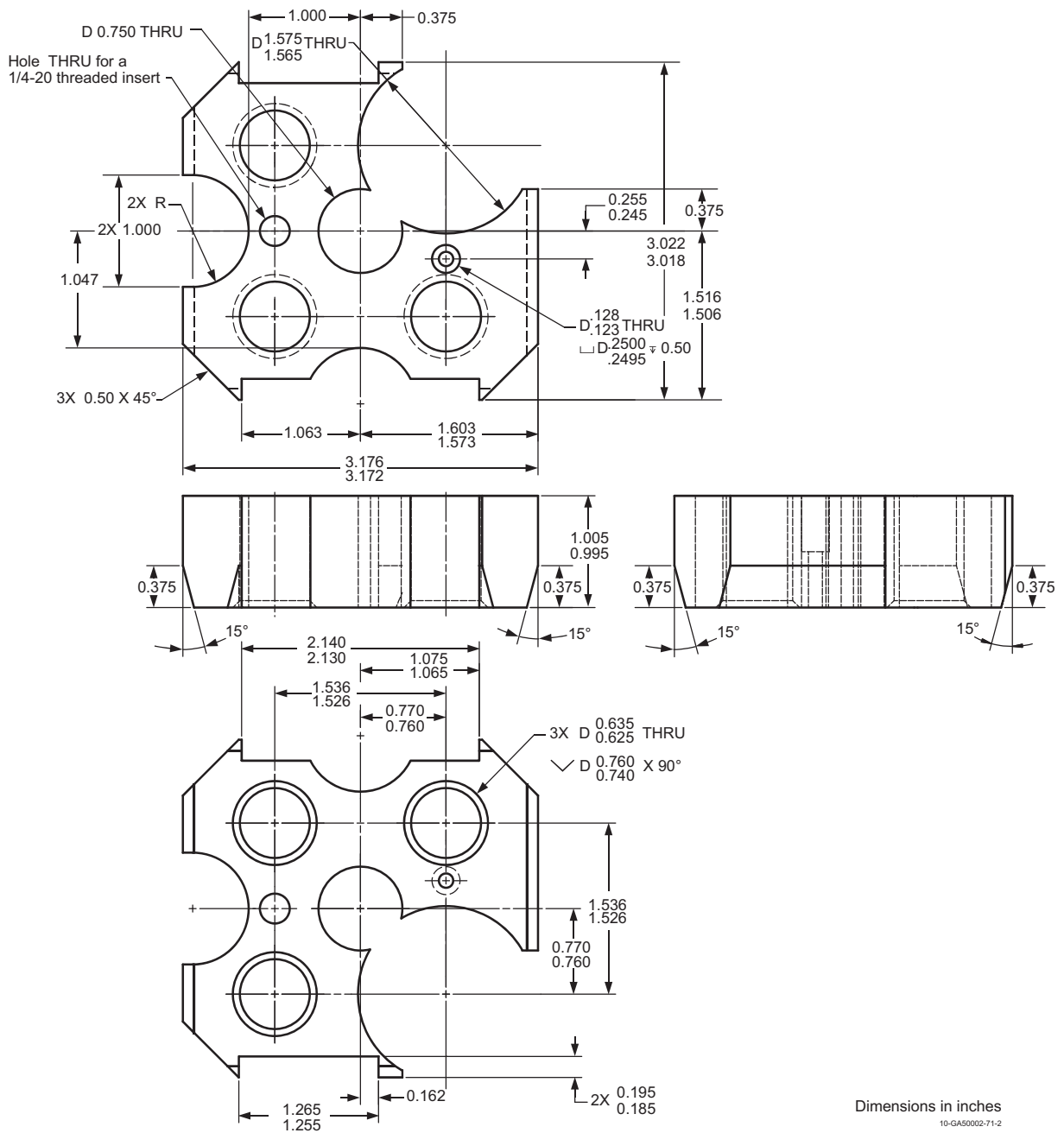

Figure 1.22c. Support Plate for D2 Three Element Cluster Assembly.

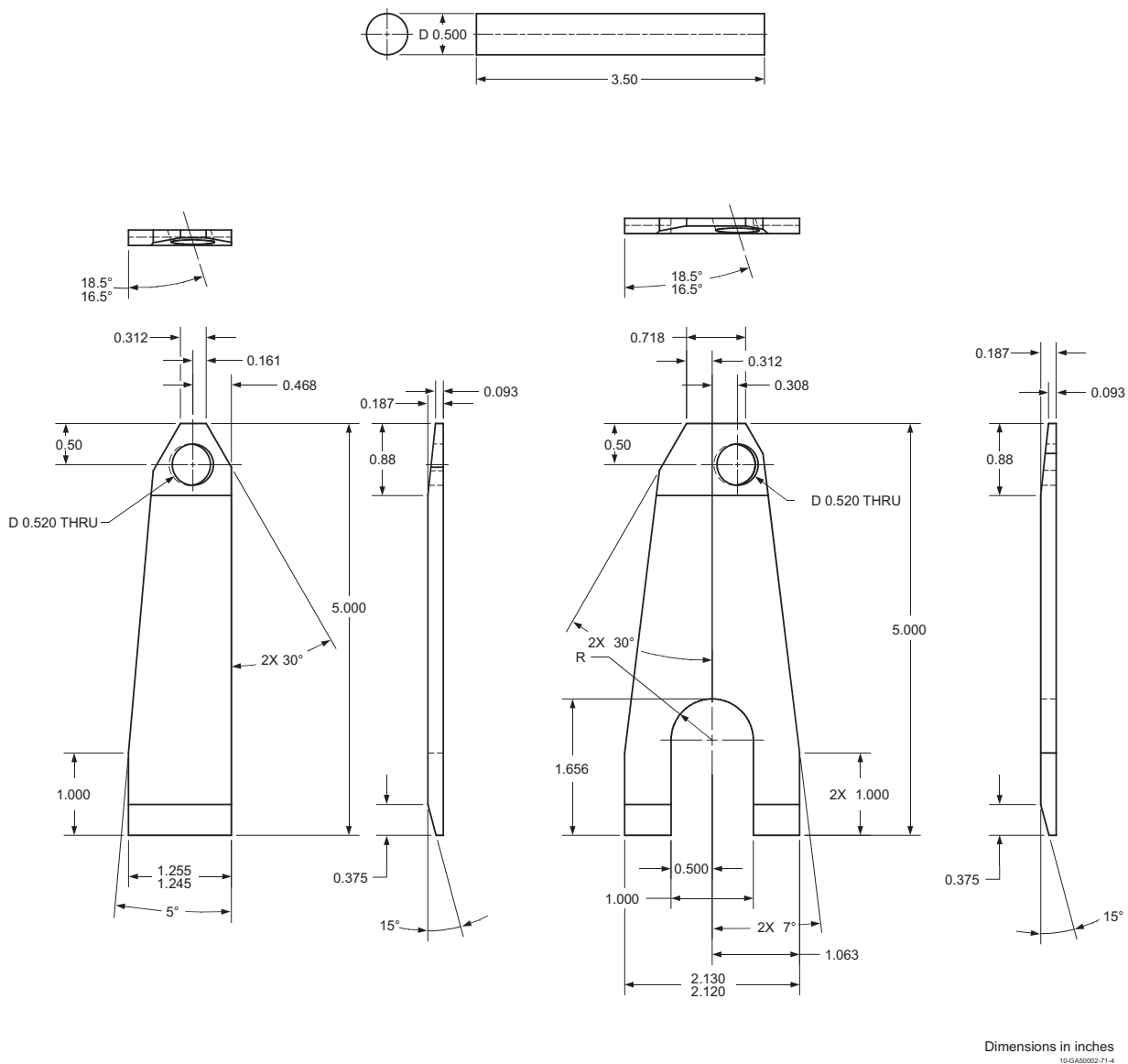

Figure 1.22d. Top Handle for D2 Three Element Cluster Assembly.

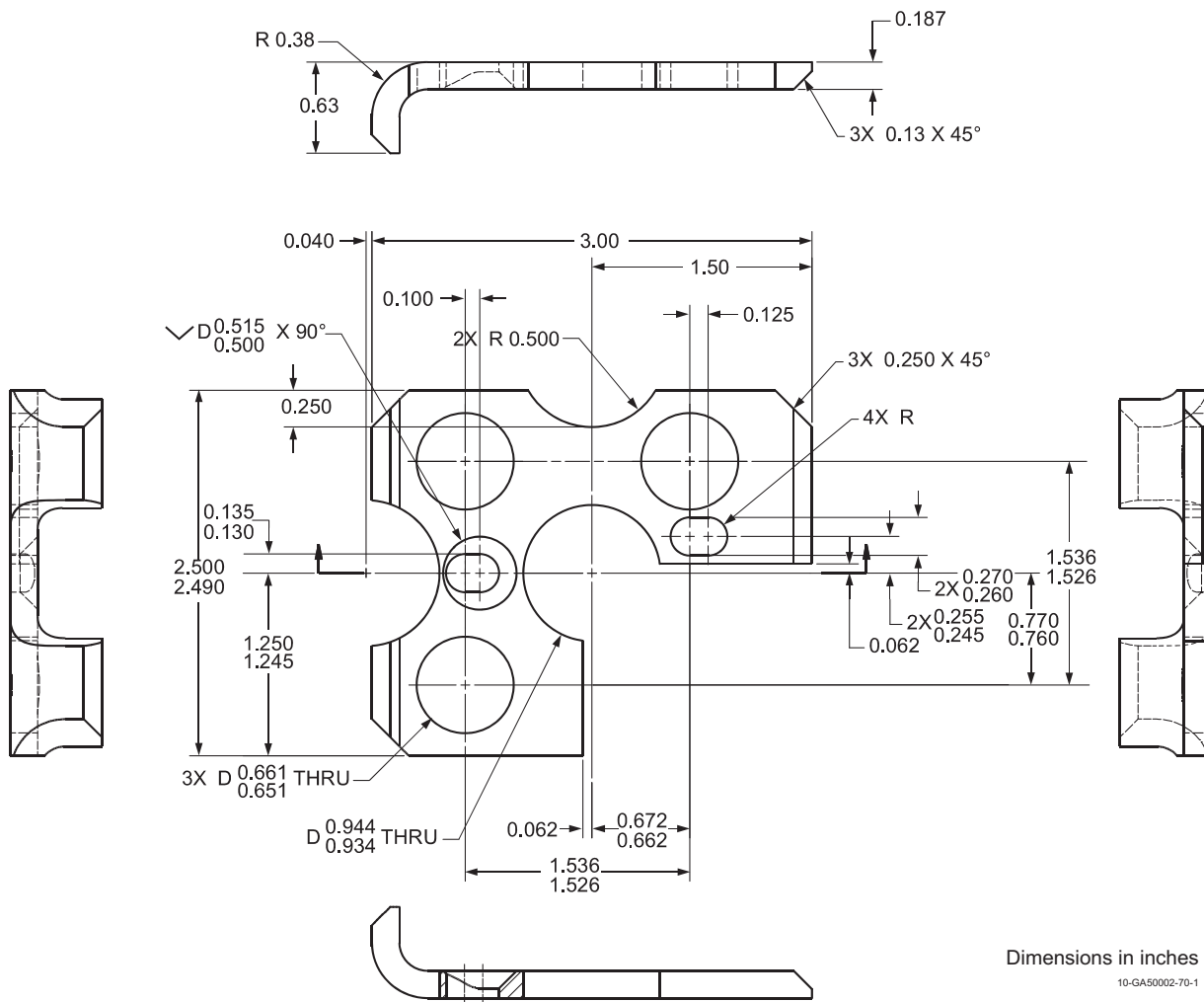

Figure 1.23a. Locking Plate for C2, C4, and E4 Three Element Cluster Assembly.

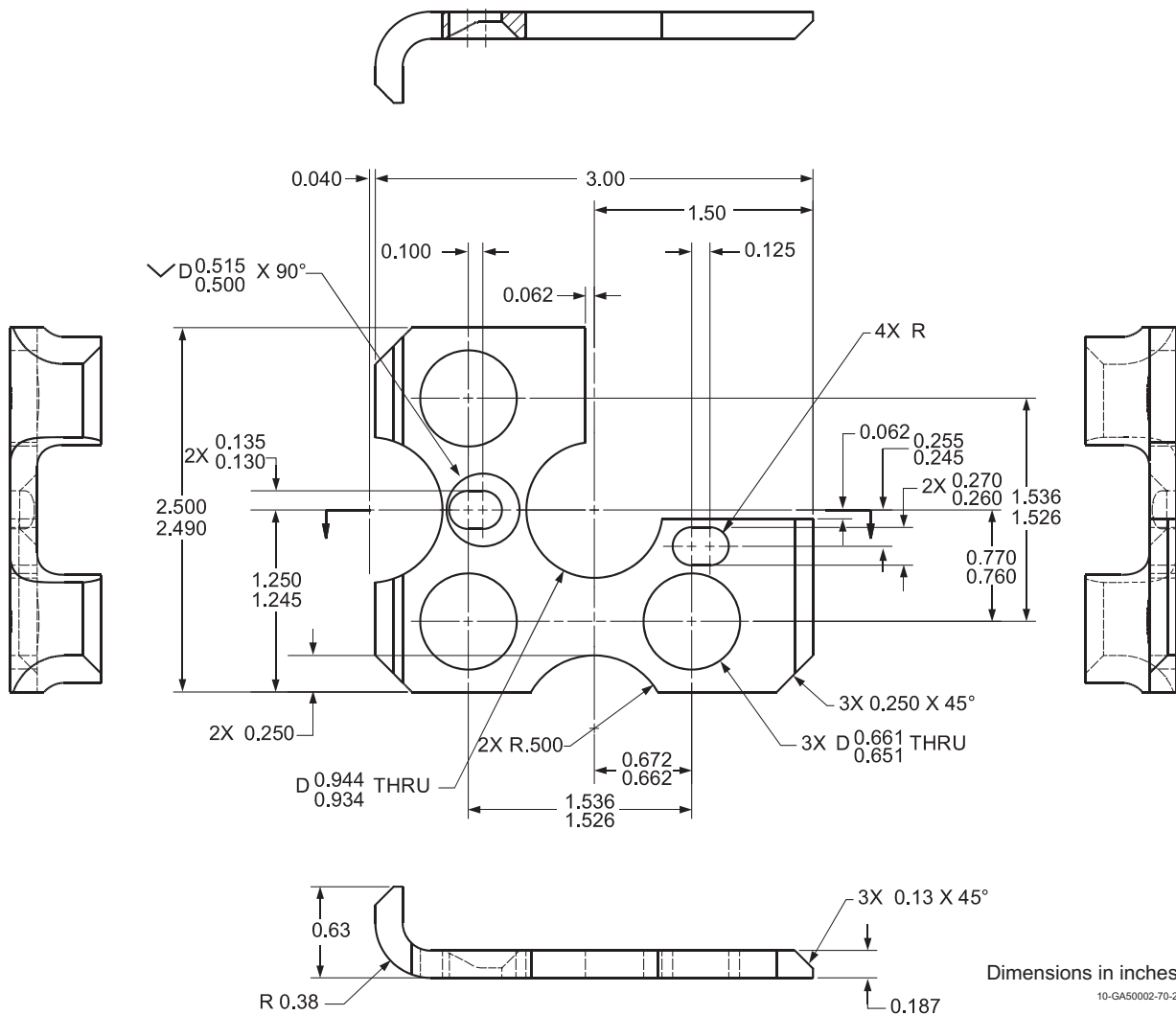

Figure 1.23b. Locking Plate for D2 Three Element Cluster Assembly.

Fuel Elements

The fuel is a mixture of uranium, erbium, and zirconium hydride. The uranium is enriched to approximately 19.75 wt.% in ^{235}U and is approximately 30 wt.% of the fuel, thus the nomenclature TRIGA LEU (30/20). The elements contain a uniform dispersion of 0.9 wt.% natural erbium that is used as a burnable poison to offset initial reactivity of the fresh fuel and contribute to the prompt negative temperature coefficient. A hole is drilled through the center of the active fuel section to facilitate hydriding of the fuel, and later filled with a zirconium rod. The zirconium rod provides structural support and prevents fuel damage during reactor operations due to fuel expansion. Finally they are clad with stainless steel.^a

A typical fuel element design is shown in Figure 1.24. The fuel element (sometimes referred to as rod) is comprised of three fuel pellets (Figure 1.25), with a zirconium rod in each (Figure 1.26), a molybdenum poison disc (Figure 1.27), and two graphite axial reflectors (Figure 1.28). These components are contained within stainless steel 304 cladding with welded top (Figure 1.29) and bottom (Figure 1.30) end fittings.

Typical design parameters for the LEU fuel to be used in the NRAD reactor are found in Tables 1.1 through 1.4. There are some discrepancies and duplication of data in these four tables. It should be noted that these parameters are typical for the TRIGA fuel used in the NRAD reactor and are reported in various documentation utilized with NRAD operations and analyses.

The gap between the fuel and cladding initially results in higher fuel temperatures for LEU TRIGA fuel. It closes over time due to burnup and fuel swelling due to fission product accumulation.^b

^a "NRAD Reactor Fuel Core Conversion," DSA-005-NRAD-ADD-3 rev. 0, Idaho National Laboratory (April 2, 2009). [This reference is not available for public release.]

^b Personal communication with John M. Bolin at General Atomics (April 22, 2010).

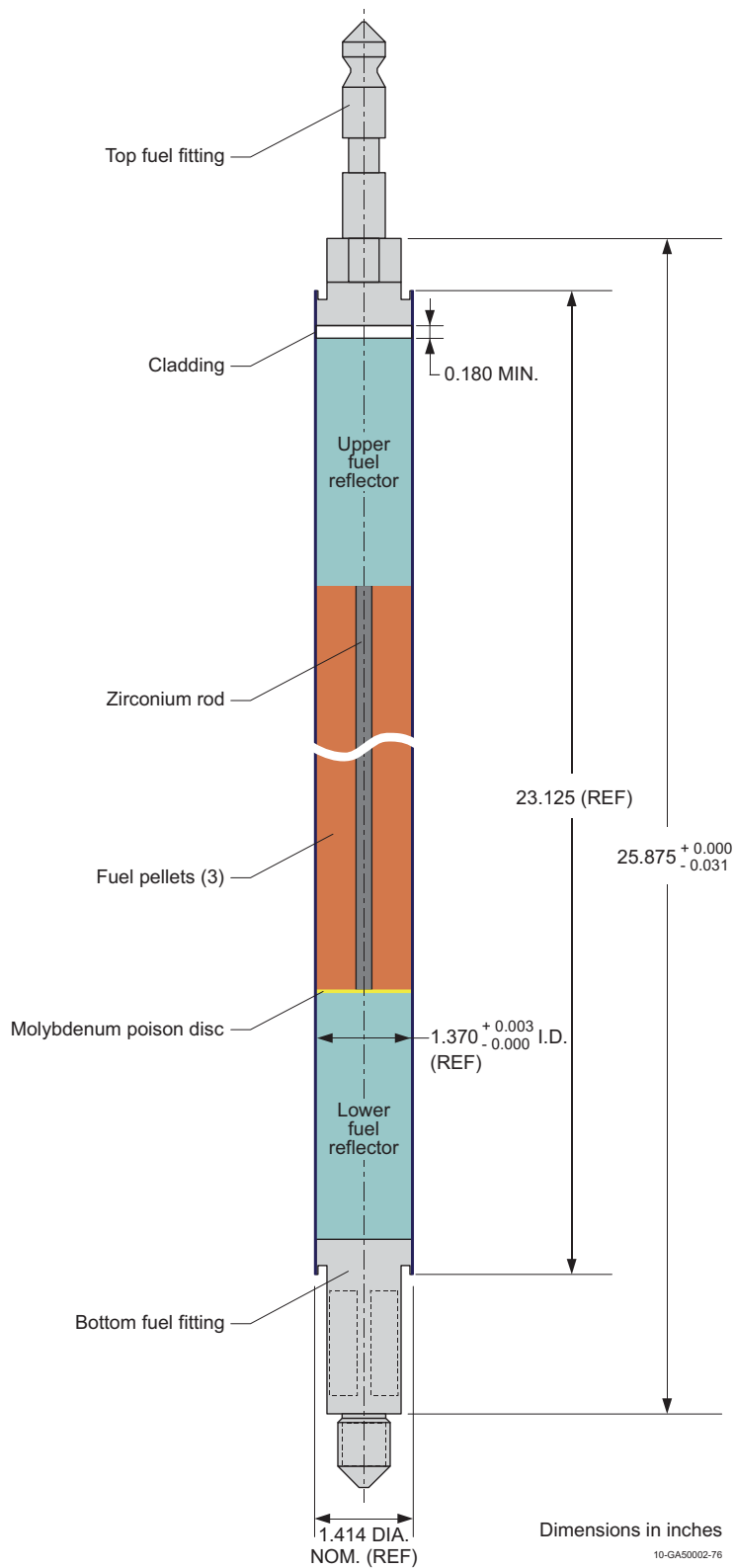

Figure 1.24. Typical TRIGA Fuel Element.

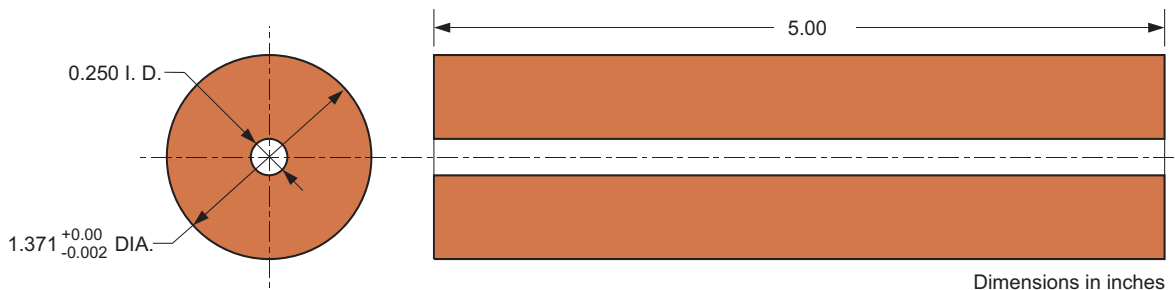

Figure 1.25. Fuel Pellet.

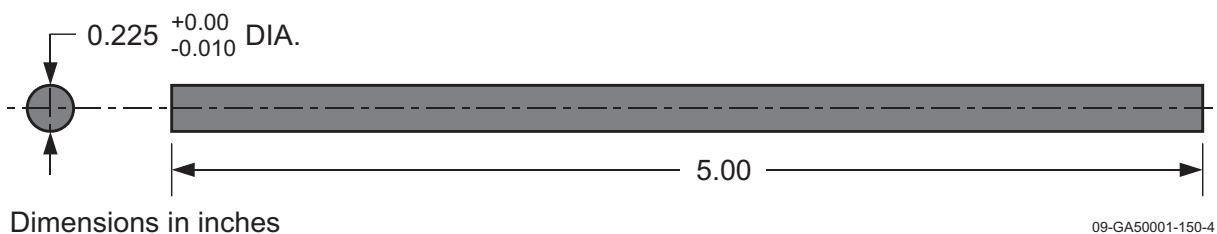

Figure 1.26. Zirconium Rod.

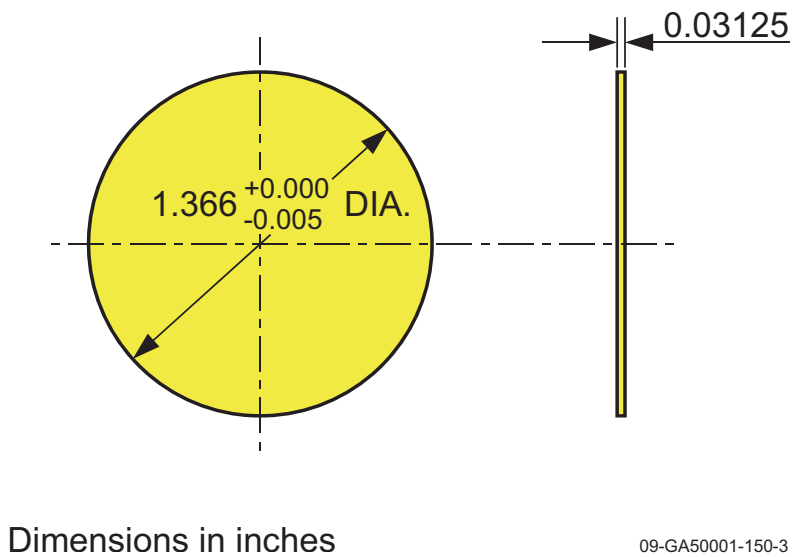
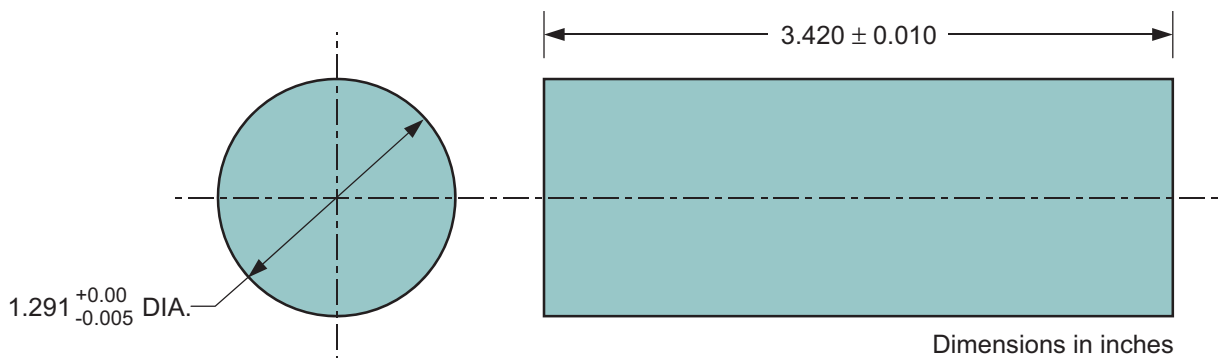
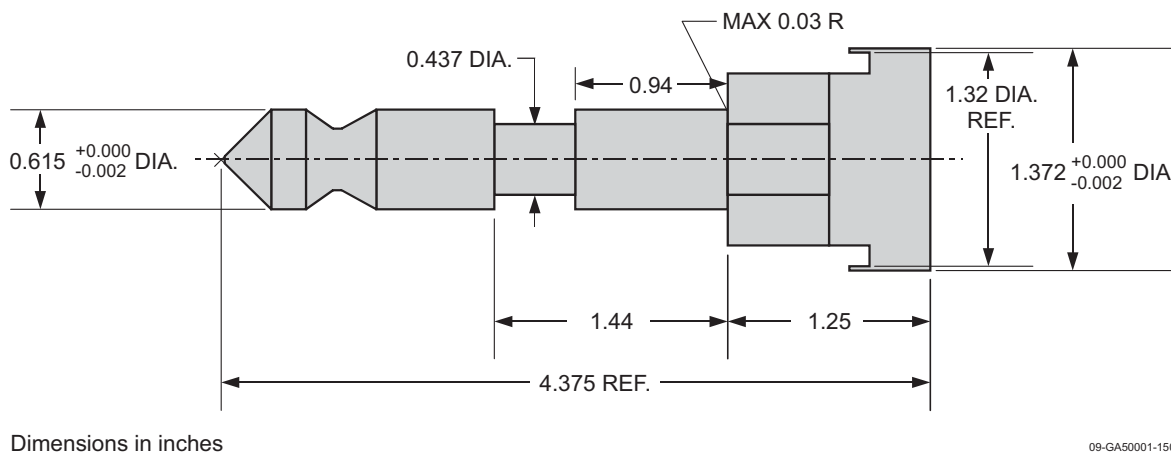

Figure 1.27. Molybdenum Poison Disc.



09-GA50001-150-6

Figure 1.28. Graphite Axial Reflector.



09-GA50001-150-1

Figure 1.29. Top Fuel Fitting.

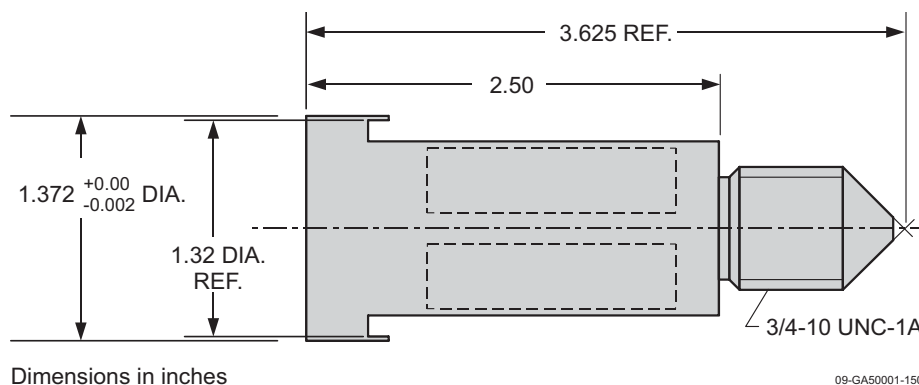

09-GA50001-150-2

Figure 1.30. Bottom Fuel Fitting.

Table 1.1. Typical Fuel (30/20) Element Specifications.^(a)

Uranium Content (wt.%)	30
²³⁵U Enrichment (wt.%)	20
Fuel Meat Length	15 in. (38.1 cm)
Fuel Meat Outer Diameter	1.371 in. (3.48234 cm)
Uranium Mass (g)	750.16
²³⁵U Mass (g)	149
Hydrogen to Zirconium Ratio	1.6
Erbium Content (wt.%)	0.8916
Zirconium Rod Length	15 in. (38.1 cm)
Zirconium Rod Diameter	0.225 in. (0.5715 cm)
Overall Element Length	30.13 in. (76.5302 cm)
Overall Element Outer Diameter	1.48 in. (3.7592 cm)
Cladding Thickness	0.02 in. (0.0508 cm)
Graphite Reflector Length (Top/Bottom)	3.42 in. (8.6868 cm)/3.42 in. (8.6868 cm)
Graphite Reflector Outer Diameter	1.291 in. (3.27914 cm)
Molybdenum Disc?	Yes
Number of U-Zr-H and Zr-Rod Sections	3

(a) L. M. Montierth, "Criticality Safety Evaluation for the NRAD Core Conversion," INL/INT-07-13231 rev. 1, Idaho National Laboratory (September 2008). [This reference is not available for public release.]

Table 1.2. Typical NRAD LEU (30/20) Fuel Design Parameters.^(a)

Number of Fuel Elements	60
Fuel Type	UZrH-Er
Zirconium Rod Diameter	5.715 mm
Fuel Meat Outer Diameter	34.823 mm
Fuel Meat Length	381 mm
Clad Thickness	0.508 mm
Clad Material	304 SS
Total Uranium (wt.%)	30.0
Uranium Density (g/cm³)	2.14
Weight of ²³⁵U (g)	149.32
Weight of ²³⁸U (g)	599.33
Uranium Enrichment (wt.%)	19.75
Total Fuel Weight (g)	2519
Erbium (wt.%)	0.90

(a) "NRAD Reactor Fuel Core Conversion," DSA-005-NRAD-ADD-3 rev. 0, Idaho National Laboratory (April 2, 2009). [This reference is not available for public release.]

Table 1.3. Additional NRAD LEU (30/20) Fuel Design Data.^(a)

Number of Fuel Elements – Critical Test	53 ^(b)
Number of Fuel Elements – Full Load	60
Fuel Type	UZrH-Er (30/20)
Enrichment (%)	19.75
Uranium Density (g/cm³)	2.14
Uranium Density (wt.%)	30
Number of Fuel Elements per Cluster	4
²³⁵U per Fuel Cluster (g)	592.43
²³⁵U per Fuel Element (g)	148.11
¹⁶⁶Er per Fuel Element (g)	7.46
¹⁶⁷Er per Fuel Element (g)	5.15
Erbium Density (wt.%)	0.90
Zirconium Rod Outer Diameter (in.)	0.225
Fuel Meat Inner Diameter (in.)	0.250
Fuel Meat Outer Diameter (in.)	1.371
Fuel Meat Length (in.)	15.0
Cladding Thickness (in.)	0.020
Cladding Material	304 SS

(a) “Neutron Radiography Reactor Analysis and Support: HEU to LEU Conversion of the NRAD Reactor, Final Report,” 911124 rev. 2, GA Project 39296, TRIGA Reactor Division of General Atomics (February 12, 2010). [This reference is not available for public release.]

(b) This number is inconsistent with actual critical test results.

Table 1.4. Typical^(a) TRIGA (30/20) Fuel Design Parameters for Cluster Assemblies.^(b)

Catalog Number	419
Drawing Number	T4S210D105
Fuel Length	15 in. (38.1 cm)
Fuel Outer Diameter	1.37 in. (3.4798 cm)
Uranium Content (wt.%)	30 ^(c)
Uranium mass (g)	710
²³⁵U Enrichment (wt.%)	20 ^(d)
²³⁵U mass (g)	141
Hydrogen to Zirconium Ratio	1.6 ^(e)
Erbium Content (wt.%)	0.9 ^(f)
Zirconium Rod Length	15 in. (38.1 cm) ^(g)
Fuel Element Overall Length	30.13 in. (76.5302 cm)
Fuel Element Overall Outer Diameter	1.41 in. (3.5814 cm)
Cladding Thickness	0.02 in. (0.0508 cm)
End Fitting Type	Threaded
Graphite Reflector Length (Top/Bottom)	2.6 in. (6.604 cm)/3.4 in. (8.636 cm)
Graphite Reflector Outer Diameter	1.3 in. (3.302 cm)
Molybdenum Disc	Yes
Samarium Trioxide Disc	No
Number of U-Zr-H and Zr-Rod Sections	3
Molybdenum Disc Thickness	0.031 in. (0.07874 cm)

(a) Variations from these typical listings do exist.

(b) R. E. Smith, "TRIGA Fuel Summary Report," ICP/INT-05-817, Idaho Cleanup Project, Idaho National Laboratory (March 2005). [This reference is not available for public release.]

(c) The nominal value of uranium content is 28.5 to 31.5 wt.% for a single fuel meat and 29.65 to 30.35 wt.% for a fuel rod assembly.

(d) The ²³⁵U enrichment is between 19.5 and 19.99 wt.% for all fuel meat.

(e) The fuel element average range of acceptance for the H/Z atom ratio is 1.57 to 1.65. Meats in the range of 1.66 to 1.70 may be used if installed as the top or bottom meat in a fuel rod assembly. The average H/Zr ratio for a fuel rod shall not exceed 1.65.

(f) Fuel erbium content is specified on a per-order basis, which is considered the nominal value. The content in an individual fuel meat is restricted to within +10% and -15% of the nominal value. A single element is restricted to between +5% and -10%. A cluster of fuel elements (containing either 3 or 4 rods) is restricted between +3% and -6%. Finally, the core content is to remain between +0% and -3% of the nominal erbium content.

(g) The length of the zirconium rod is always the same length as the fuel segments.

Control Rods

The NRAD reactor uses PRNC-type control rods, control-rod drives, and instrument console. It is controlled by three boron-carbide cylindrical control rods (two shim rods and one regulating rod). All three control rods are supported from the bridge structure located at the top of the reactor tank and are water-followed when withdrawn from the core.^a

Positions of the control rods are shown in Figure 1.6. The shim control rods are in positions D-2 SE and C-2 NE. The regulating control rod is located in position E-4 NE. Any one control rod can shut down the reactor.

The control elements for the NRAD reactor can be either the original PRNC control rods with 0.5 MW-year of operation or new ones purchased from General Atomics with the same part number as those used at the PRNC.^a All three control rods currently in the core are from the original PRNC reactor.

Each control rod consists of a boron carbide (B_4C) poison section that is 15 in. (38.1 cm) long and 1.19 in. (3.0226 cm) in diameter contained within an aluminum 6061-T6 tube 24 in. (60.96 cm) long with an outer diameter of 1.25 in. (3.175 cm) and a wall thickness of 0.028 in. (0.07112 cm). The container has a $\frac{1}{2} \times 13$ threaded connection on the upper end for attachment to an extension rod. A diagram of the control rod is shown in Figure 1.31.^a

Full travel of an NRAD control rod is 15 in. (38.1 cm). The rod position indication displays 0-1000 units of travel from a down limit switch to the up limit switch, respectively. Each unit of display is equal to 0.015 in. (0.0381 cm) of rod travel. A good confidence band (3σ) for knowing the location of the control rod is ± 4 units (0.06 in., 0.1524 cm). The drive travel in the reactor room was physically measured and validated that the full travel length is 15 in. The digital position indication is adjusted at the zero, down limit, and again at 1000 units, or the upper limit, using potentiometers on the back of the reactor console. As much as -3 units to zero units at the lower limit and 999 or 1000 units at the upper limit is allowed.^b

Control rod position data are obtained from a potentiometer connected to the drive pinion. Limit switches are provided to indicate the up and down positions of the magnet, and magnet contact with the control rod.^c

The bottom of the control rod is 0.75 in. (1.905 cm) above the inside bottom of the control rod guide tube when the control rod is completely inserted. The bottom end of a control rod is shown in Figure 1.32.

^a "NRAD Reactor Fuel Core Conversion," DSA-005-NRAD-ADD-3 rev. 0, Idaho National Laboratory (April 2, 2009). [This reference is not available for public release.]

^b Personal communication with Ken Schreck at HFEF (April 5-6, 2010).

^c "HFEF/N Neutron Radiography Facility System Design Description," W0170-0004-SA rev. 2, Idaho National Laboratory (June 1, 1978). [This reference is not available for public release.]

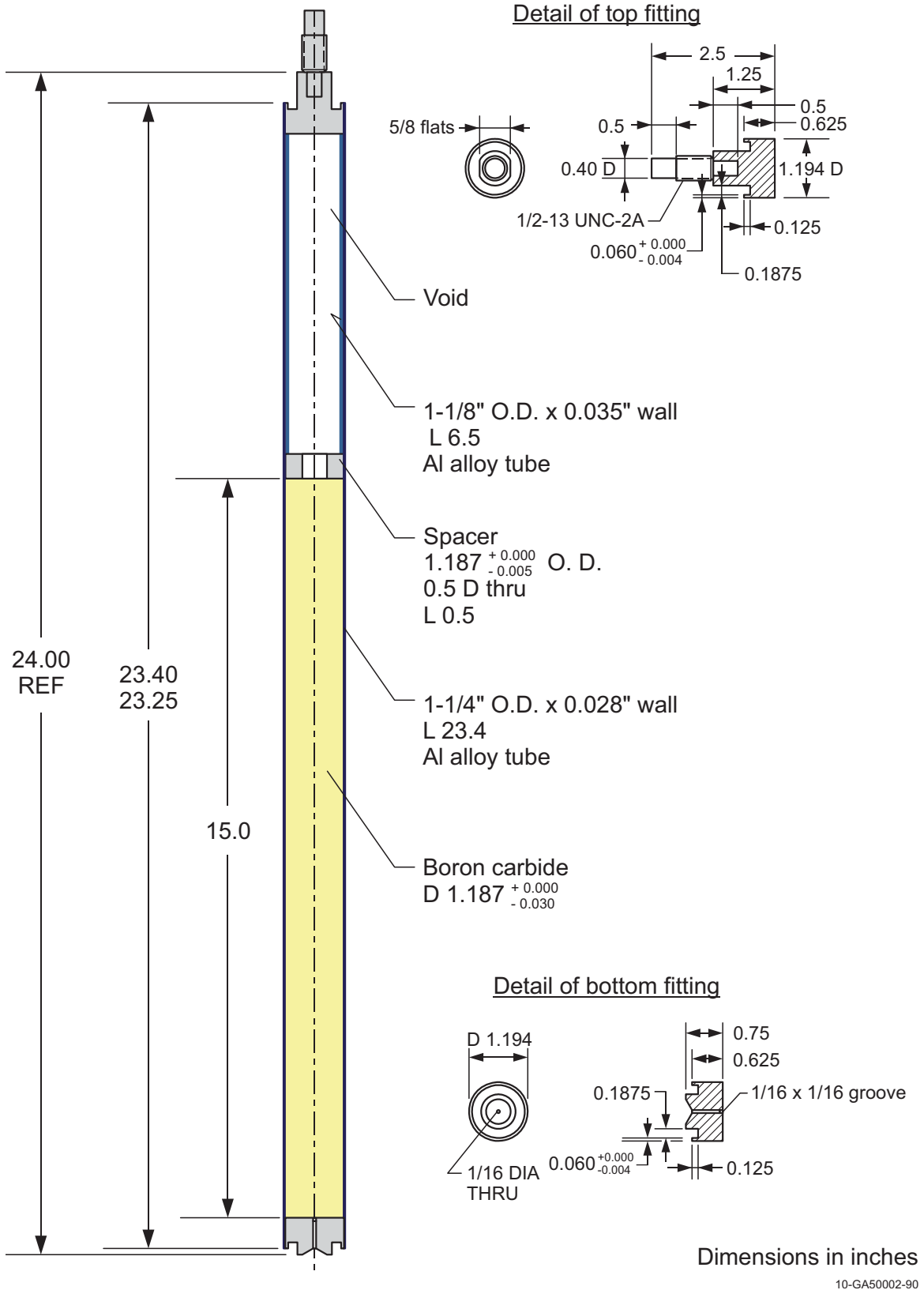

10-GA50002-90

Figure 1.31. NRAD Control Rod.



Figure 1.32. Bottom of Control Rod.

An aluminum extension, or connection, rod is attached to the control rod, connecting it to the driveline, control rod drive, instrumentation, and support structure located above the reactor core and tank. The extension rod is 33.750 in. (85.725 cm) long and is a tube with an outer diameter of 0.875 in. (2.2225 cm) and an inner diameter of 0.635 in. (1.6129 cm). The assembly interface of the extension rod to the control rod is depicted in Figure 1.33 and a photograph of the interface is shown in Figure 1.34.

A guide tube placed into the three-fuel-element cluster assemblies is used to direct the vertical movement of the control rod. Figure 1.35 shows the guide tube and Figures 1.19 and 1.20 demonstrate how the guide tube is placed into the three fuel element cluster assembly. New guide tubes were fabricated in 2009.

Assembly 2 in Figure 1.35 shows how the weldment goes together, representing an intermediate step in the construction process of the guide tube. Once the tube is connected to the fitting, it is turned and pulled. A 0.1875 in. (0.47625 cm) diameter, 1.5 in. (3.81 cm) long, 18-8 stainless steel dowel pin holds the guide tube base and bottom adapter together.

An empty guide tube is used to guide experiments into an irradiation position in the core.

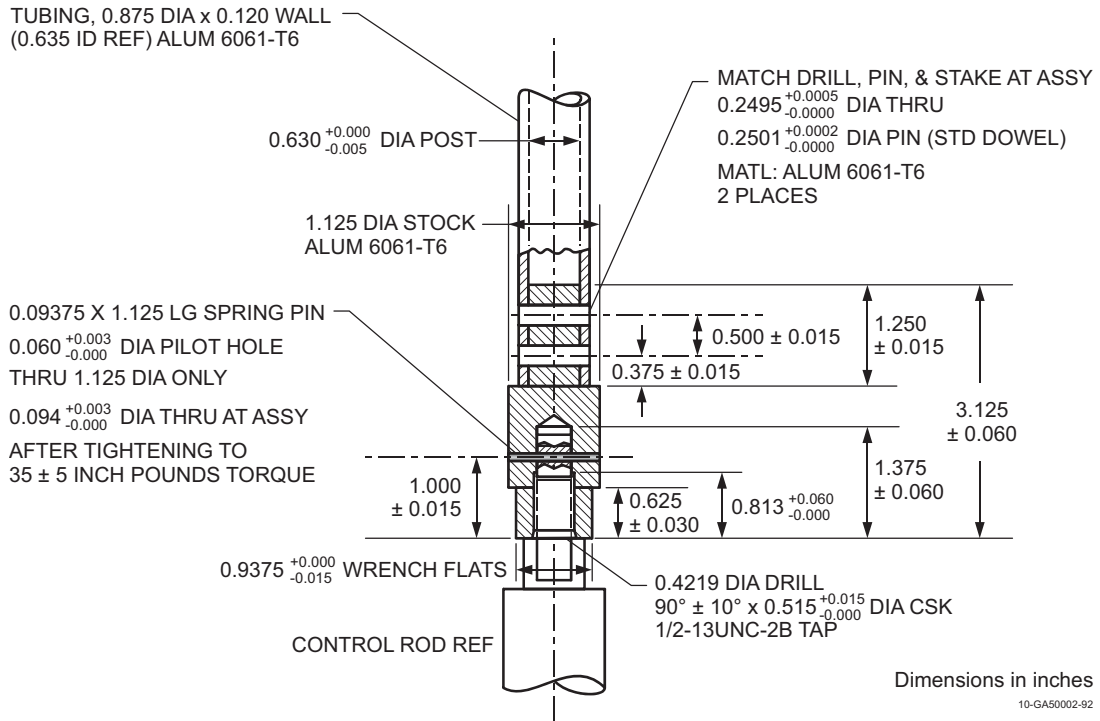

Figure 1.33. Interface between Control Rod and Extension Rod.



Figure 1.34. Interface between Control Rod and Extension Rod.

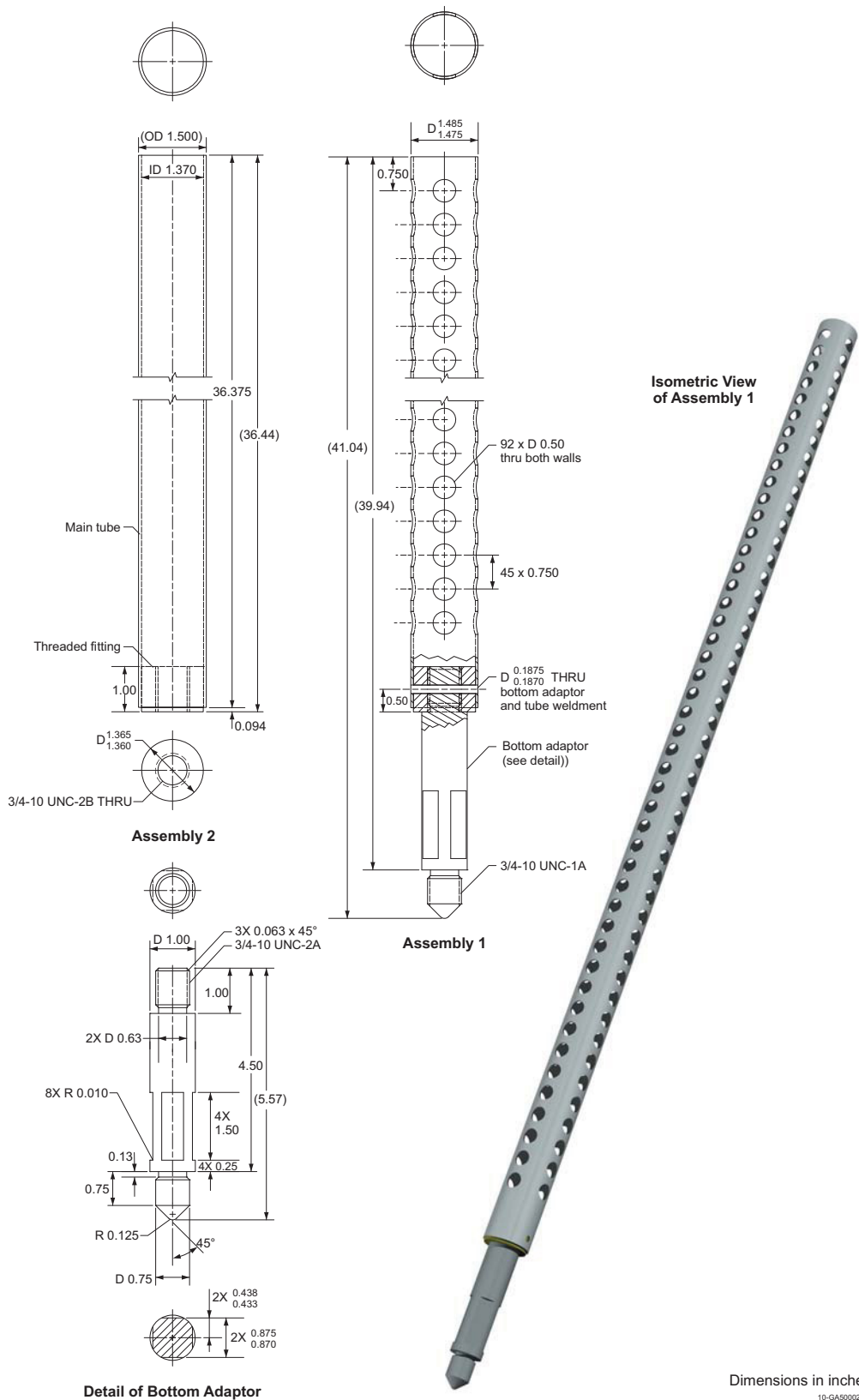

Figure 1.35. Control Rod Guide Tube.

Graphite Reflector Assembly

Graphite reflector assemblies are located in the periphery grid plate locations. The top and bottom of each reflector assembly have adapters for handling and insertion into the core grid plate. The assemblies, as shown in Figure 1.36, are 25.9 in. (65.786 cm) long and have a horizontal cross section in a square shape, with each side of the square 2.9 in. (7.366 cm) in length.^a

Dimensions of the graphite block are shown in Figure 1.37. The top cast assembly fitting is shown in Figure 1.38. The bottom fitting was replaced with those used for the fuel assemblies, shown in Figure 1.14. The assembly fittings are attached to the graphite blocks using aluminum 2011-T3 socket head cap screws, tie rod, and stud, as shown in Figure 1.36.

Photographs of unmachined graphite identical to that used in the NRAD graphite assemblies are shown in Figure 1.39.

^a "HFEE/N Neutron Radiography Facility System Design Description," W0170-0004-SA rev. 2, Idaho National Laboratory (June 1, 1978). [This reference is not available for public release.]

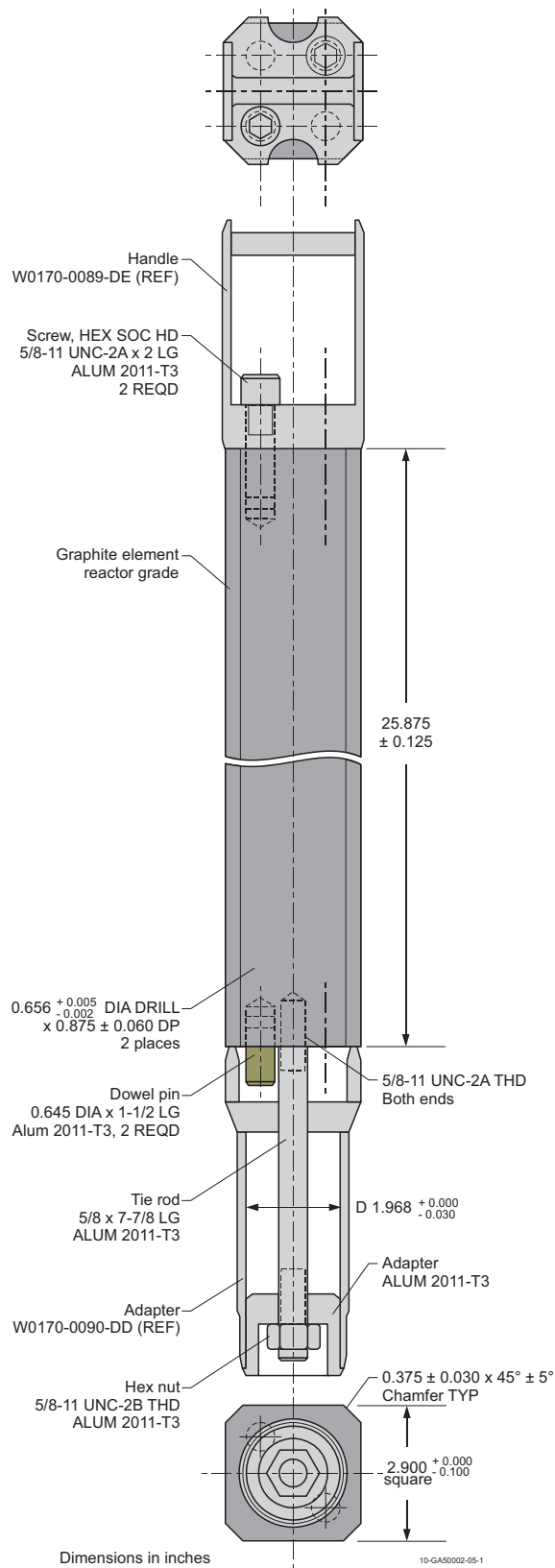

Figure 1.36. NRAD Graphite Reflector Assembly.

NRAD-FUND-RESR-001
CRIT-REAC-COEF

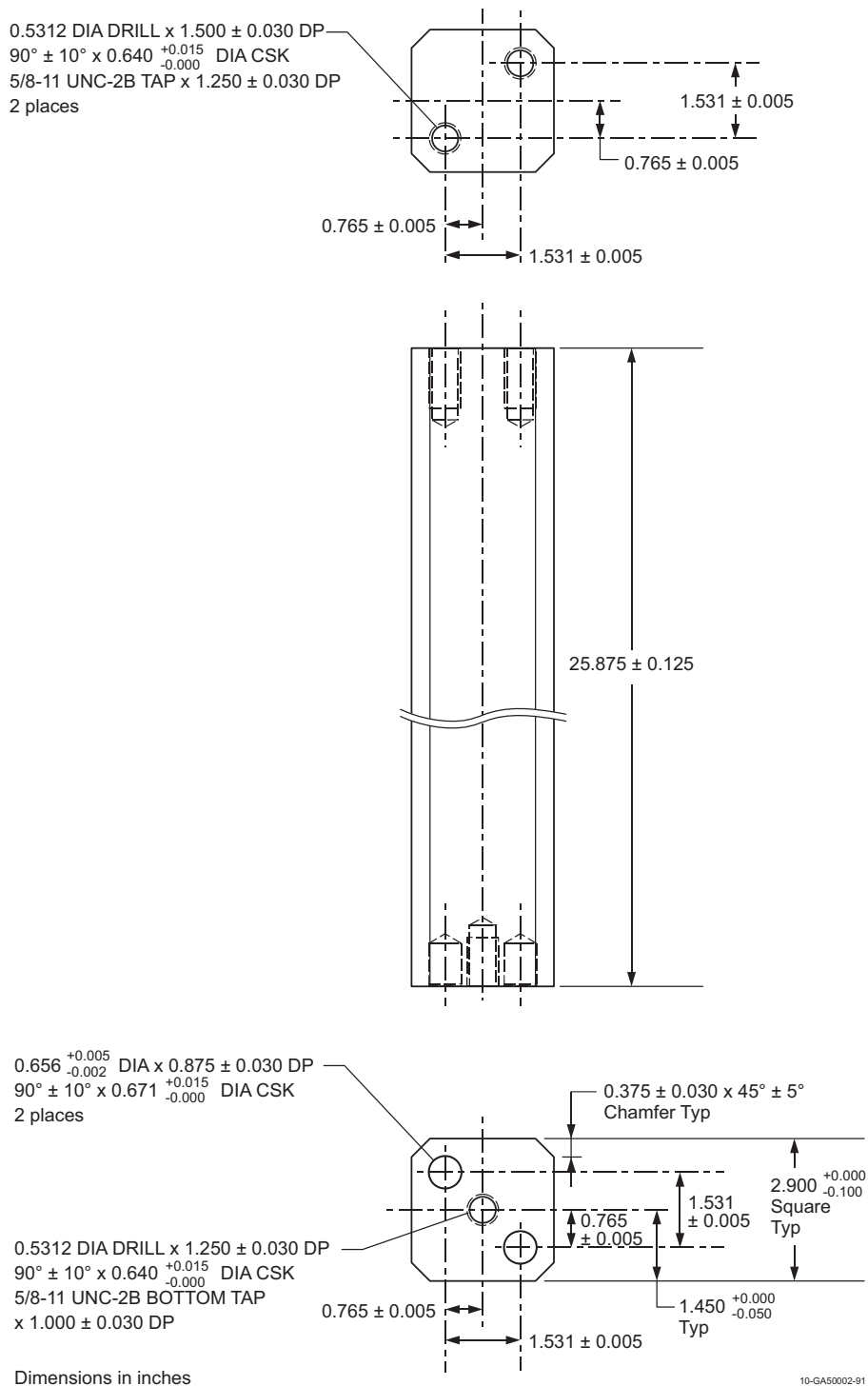

Figure 1.37. Graphite Reflector Block.

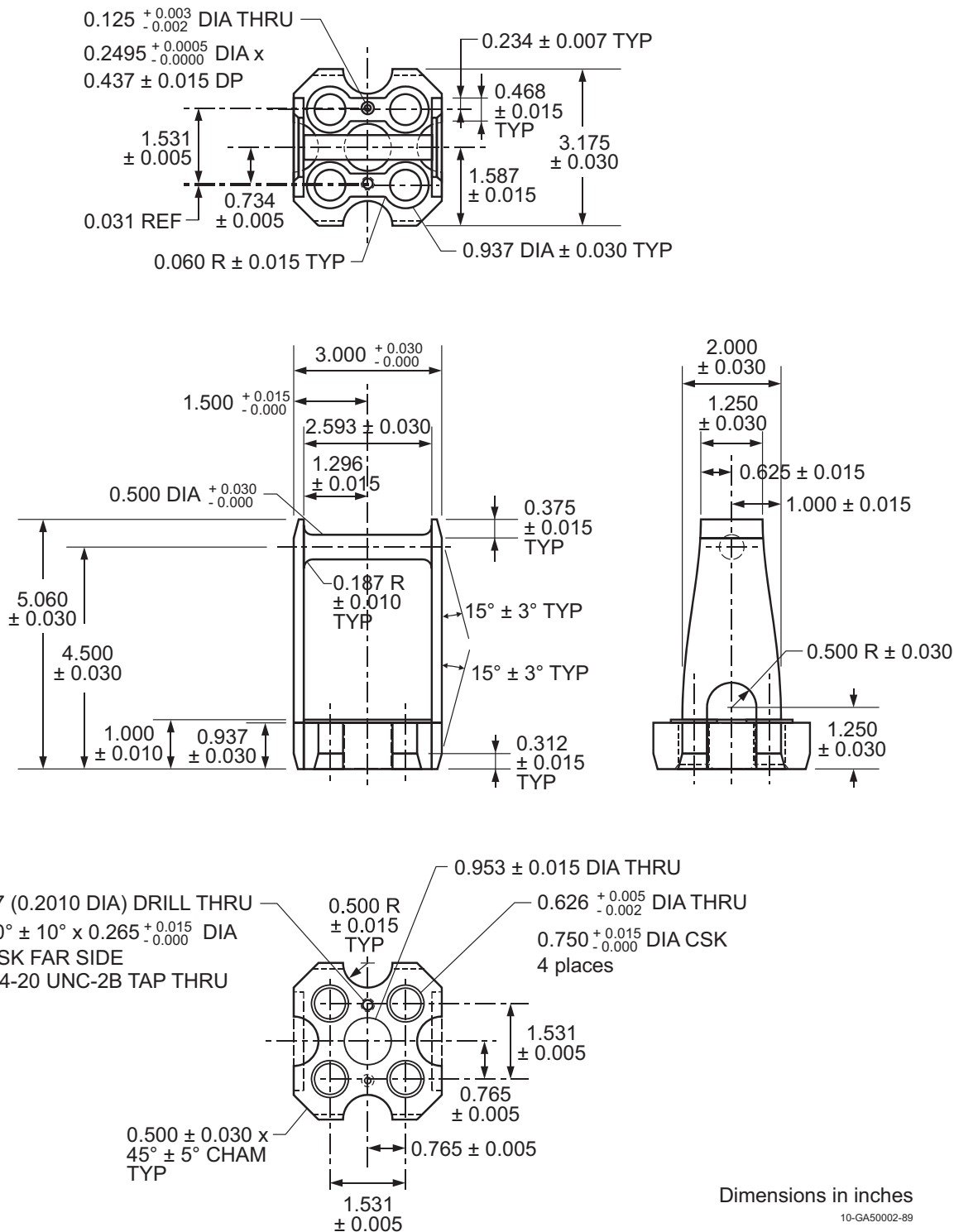

Figure 1.38. Graphite Reflector Top Assembly.

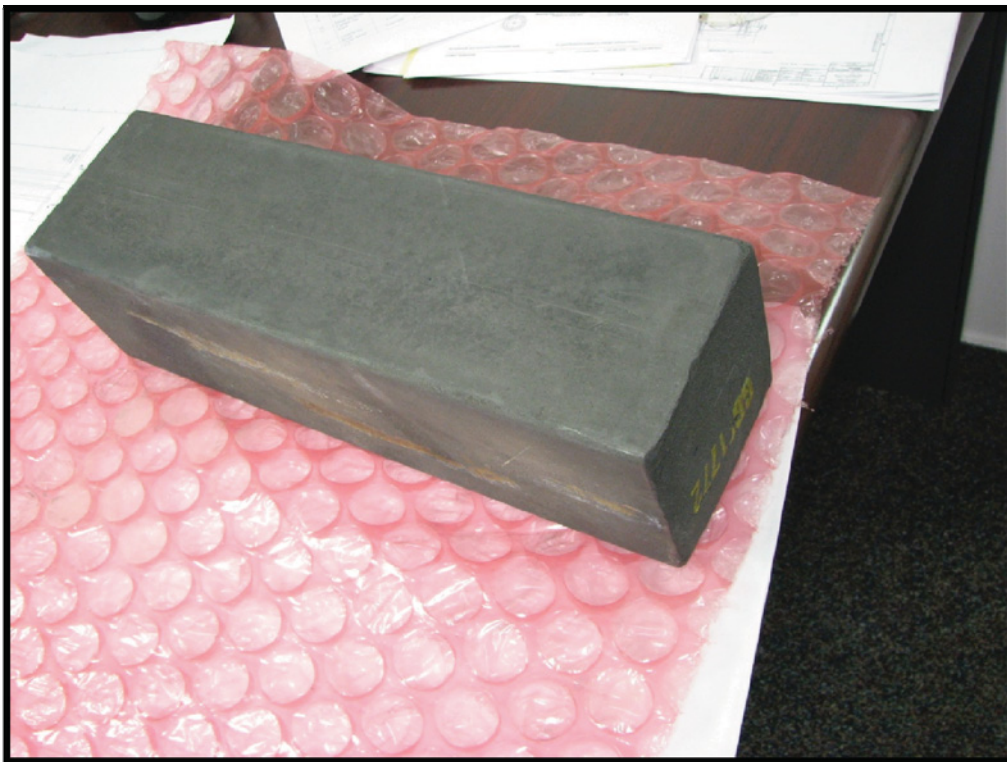

Figure 1.39. Unfinished Graphite Reflector Block.

Beam Ports

The NRAD reactor services two radiography stations, as shown in Figures 1.2 through 1.4. The main radiography station is used to neutron-radiograph highly irradiated fuel elements, fuel assemblies, and loop experiments, which might chemically react with air. This station is located within HFEF's main cell, which contains argon atmosphere. The second neutron radiography station is located outside of the main cell, allowing for the irradiation of either irradiated or unirradiated specimens, and is filled with air at ambient conditions.

The two beam tubes are positioned to the North (to secondary station) and East (to main station) sides of the reactor core. The in-tank portion of the beam lines includes a beam-filter tube and an aperture mechanism that excludes water from the neutron path. A through-the-wall collimator encased in the concrete of the reactor-room shielding and walls then extends from the reactor tank to the radiography station.^a

The in-tank portion of the East beam line (Figure 1.40) is an air-filled aluminum tube extending from the reactor core to the reactor tank wall. The aperture mechanism (Figure 1.41) is placed approximately midway and is housed in a water-tight aluminum box, sealed at the top, and extends upward to the top shield. This housing contains the aperture elements and remotely operated mechanism for changing the size of the aperture. The beam filter tube that extends from the core to the aperture mechanism is removable, to allow for loading of additional filter material when required. It is usually filled with helium. The inner end of the tube extends to about 0.8 in. (2.032 cm) from the outermost fuel elements.^a

The beam-filter tube (Figure 1.42) is rectangular in cross section. Clamp rails force the beam-filter tube into intimate contact with the window of the aperture housing, leaving just a thin film of water along the interface. A bolted flange at the top of the tube allows access for loading. The bottom of the aperture housing extends to the tank floor to provide additional support. The source tube then extends from the aperture mechanism to the tank wall, where the flange on the source tube is sealed to the flange of the nozzle welded to the tank wall. The nozzle is equipped with gas-purge fittings to remove water from the tube after any operations requiring the removal and reinstallation of the aperture housing. The fittings also allow for maintenance of a helium-filled atmosphere. A Boral lining, 0.265-inch-(.6731-cm)-thick, is provided to minimize neutron scatter and monitor seal leakage.^b

The beam-filter tubes are also referred to as "wet packages" when referenced in reactor operations.

Figure 1.3 provides the general layout of a beam line in the NRAD reactor facility.

A 55 ft (16.764 m) helium-filled beam tube extends from the north face of the reactor to the secondary radiography station. The aperture mechanism is identical to that of the east beam tube with different neutron beam length/diameter (L/D) ratios because of the difference in beam tube length.^a

The aperture mechanism provides control of some neutron beam properties. The smaller the aperture, the sharper the definition of the neutron radiograph (with longer exposure time required). There are three apertures: 3.5 in. (8.89 cm) with an L/D of 50, 1.39 in. (3.5306 cm) with an L/D of 125, and 0.59 in. (1.4986 cm) with an L/D of 300. The two smaller apertures are located in a movable aperture block (Figure 1.43) while the largest aperture is in a fixed block (Figure 1.44) that is uncovered when the movable block is driven up out of the way. Both movable and fixed blocks are made from boron nitride.^b

^a "NRAD Safety Analysis Report," DSA-005-NRAD rev. 5, Idaho National Laboratory (April 2, 2009). [This reference is not available for public release.]

^b "HFEF/N Neutron Radiography Facility System Design Description," W0170-0004-SA rev. 2, Idaho National Laboratory (June 1, 1978). [This reference is not available for public release.]

The movable aperture block is held within an aperture assembly (Figure 1.45) and is vertically supported by an aperture block guide (Figure 1.46) and aligned with an aperture block adjusting screw (Figure 1.47). A lower tube seal plate (Figure 1.48) is used for the fixed block disc aperture.

The L/D ratios for the North beam tube are 185, 300, and 700 for the same aperture dimensions as the East beam tube.^a

Graphite reflector assemblies are not used in the center East and North sides of the core to allow for the beam tubes to have closer access to the fuel, as shown in Figure 1.6. These positions (A-3, A-4, C-6, and D-6) instead contain an in-core beam tube support structure comprised of aluminum 6061 (Figure 1.49). A hex head cap screw can be adjusted to the desired height to provide support for the beam filter tubes extending into the core from the beam apertures. The centerline of the beam tube is located at core midplane.

The aperture setting of the East beam tube at the time of the experiments was at its typical L/D setting of 125. The aperture setting of the North beam tube was also at its typical L/D setting of 300. Both of these settings indicate that the moveable aperture block (Figure 1.43) was raised such that the lower hole was aligned with the path of the beam tube. The East beam filter tube was filled with air and the North with helium. However, the tubes may be filled with either gas, or evacuated to contain void space (i.e. vacuum).

The original drawings for the beam assemblies are different in regards to beam filter tube length (due to the difference in the length and width of the core grid plate) and the depicted layout of the aperture assembly mechanism. However, the current positioning motors in the reactor room conflict with the description of the North beam tube aperture assembly and match that of the East beam line. Therefore, based on the configuration of the motors, the staff believes that the North beam arrangement is identical to the East beam arrangement, except for the length of the “wet package”.^b

^a G. R. Imel, G. C. McClellan, and D. P. Pruett, “The Neutron Radiography Reactor (NRAD),” CONF-900873--2, *Proc. 1st Int. Top. Mtg. Neutron Radiography System Design and Characterization*, Pembroke, Canada (August 28-30, 1990).

^b Personal communication with Ken Schreck at HFEF (April 29, 2010).

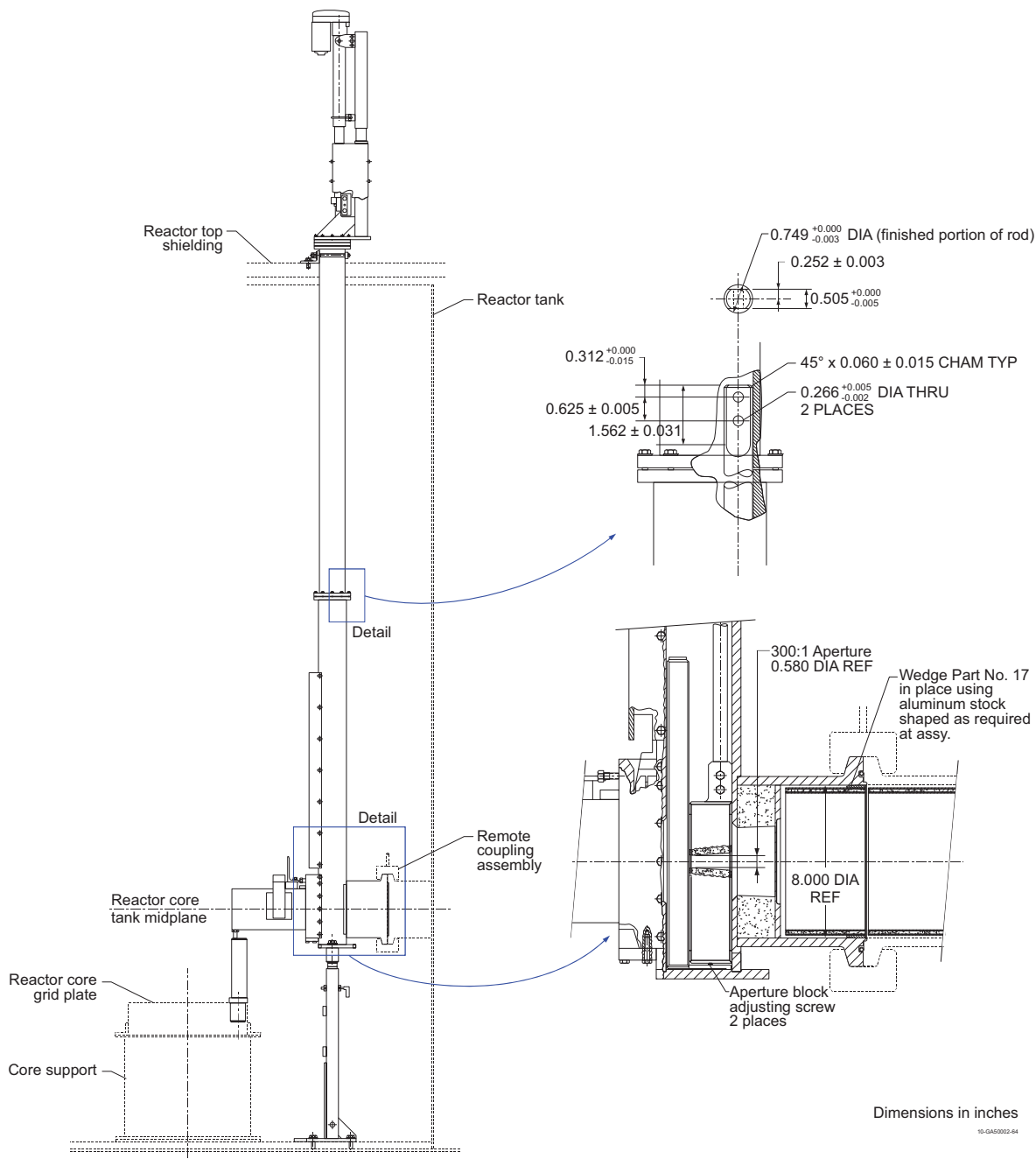

Figure 1.40. In-Tank Portion of the Beam Line.

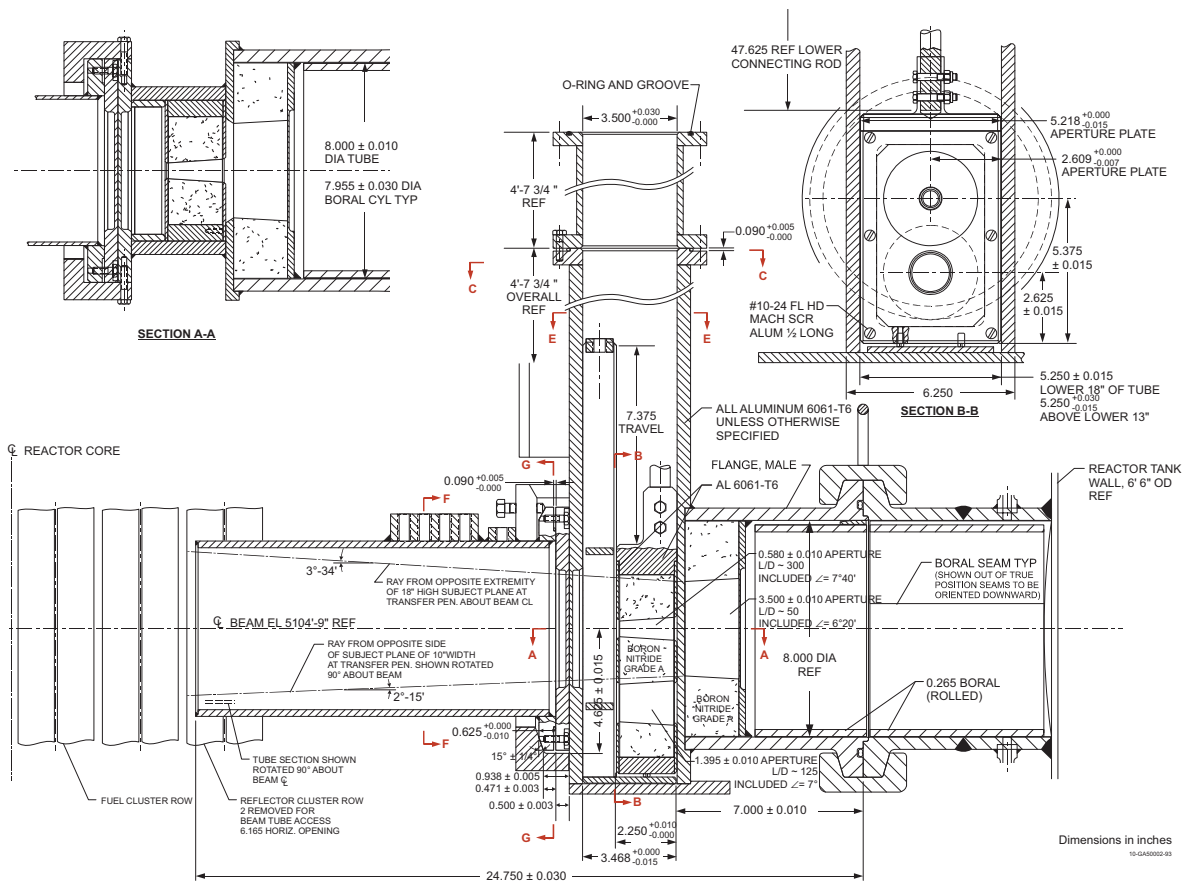

Figure 1.41a. East Beam Line Aperture Mechanism.

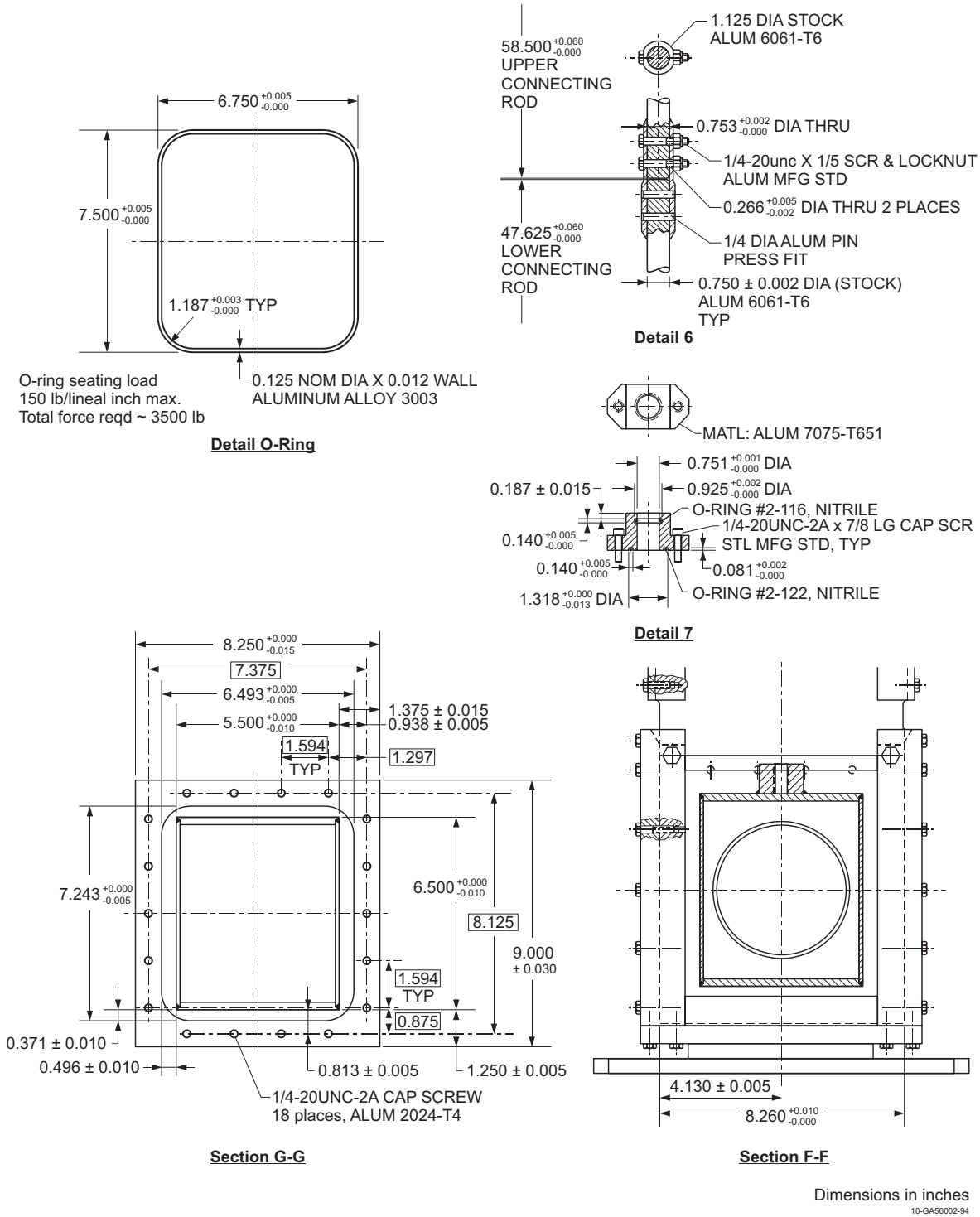
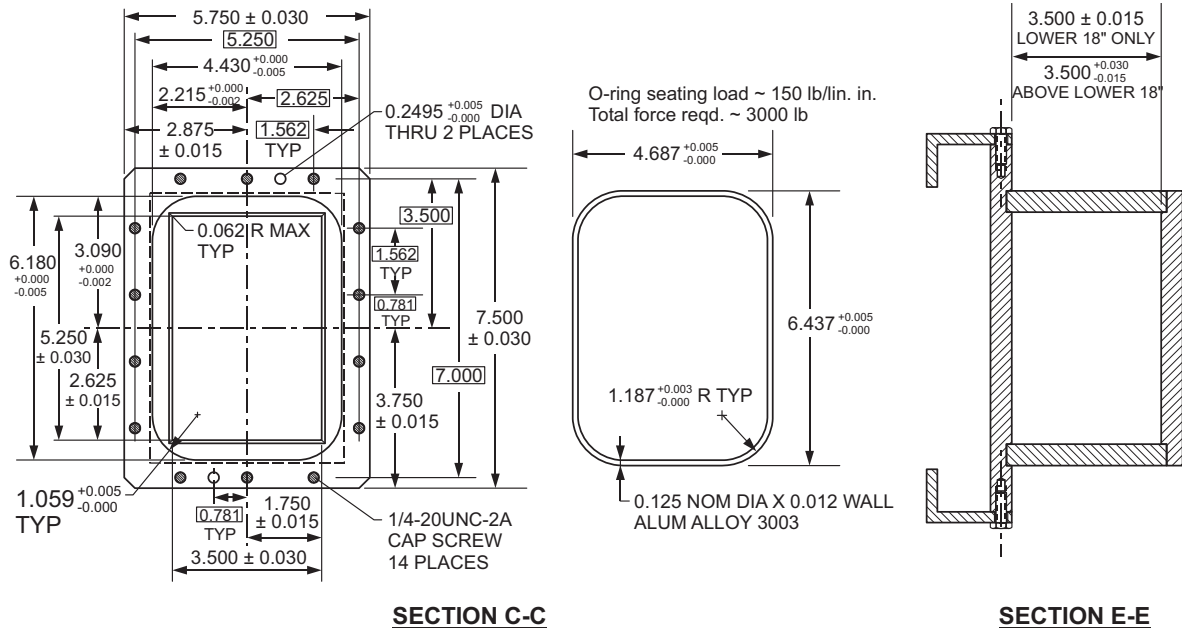

Figure 1.41b. East Beam Line Aperture Mechanism.



Dimensions in inches

10-GA50002-95

Figure 1.41c. East Beam Line Aperture Mechanism.

NRAD-FUND-RESR-001
CRIT-REAC-COEF

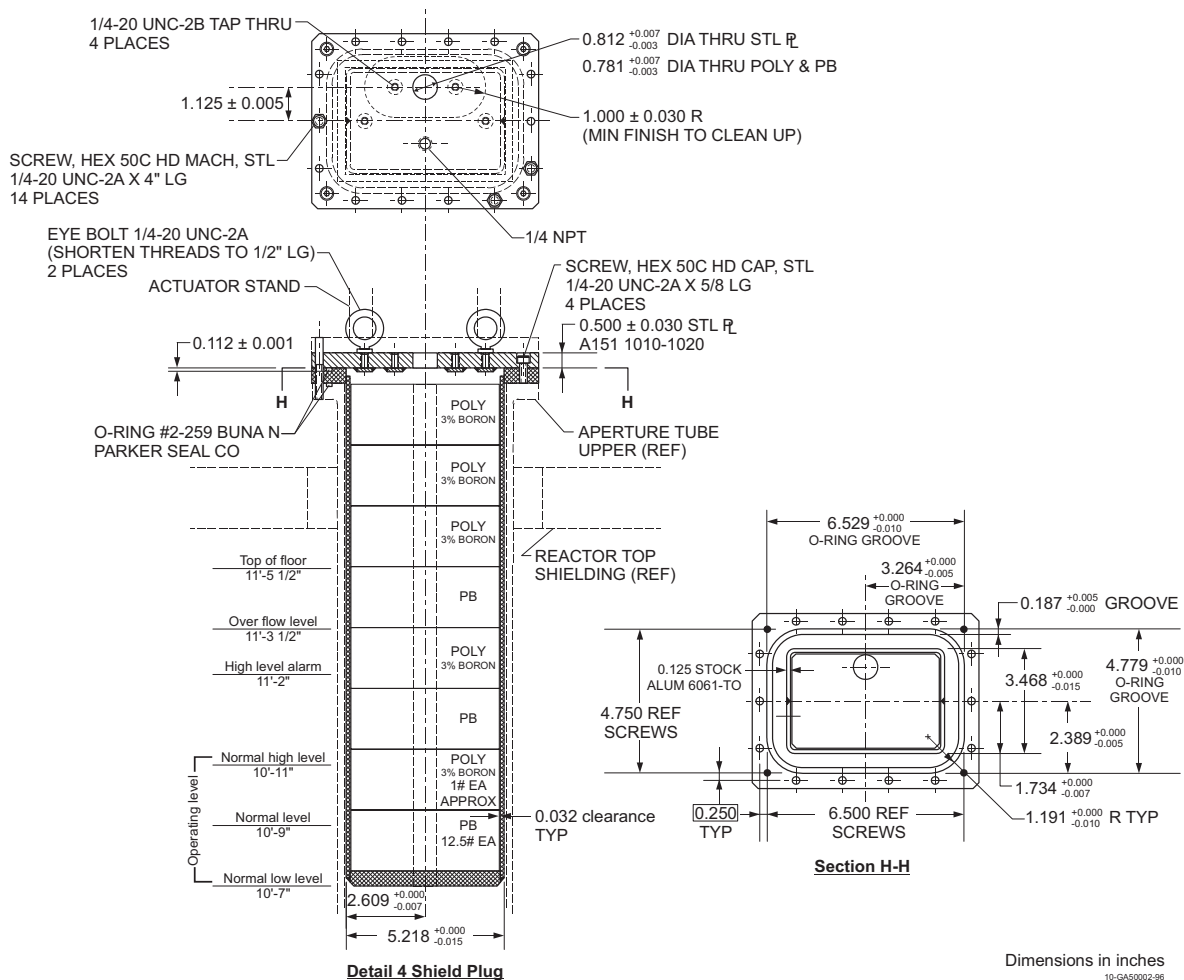

Figure 1.41d. East Beam Line Aperture Mechanism.

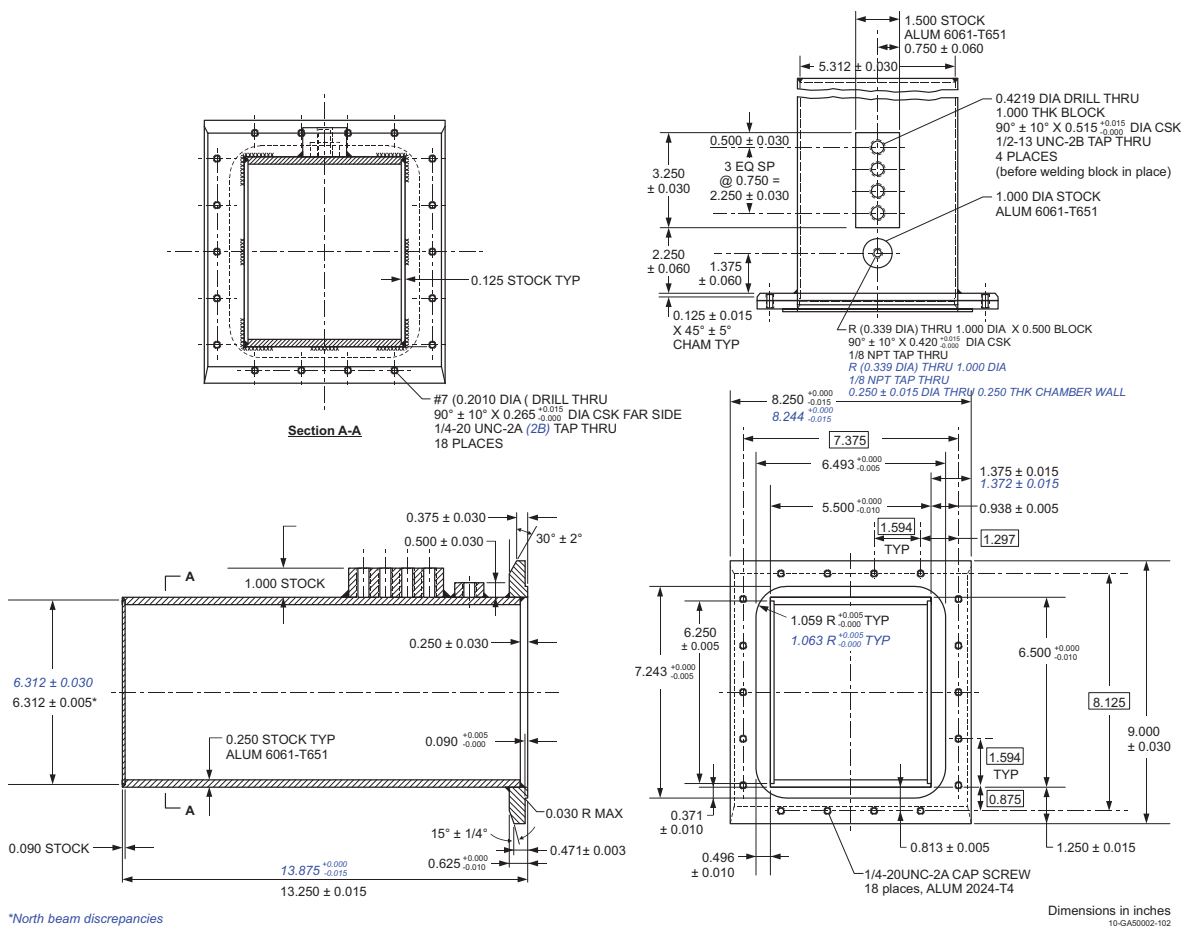

Figure 1.42. East and North Beam Filter Tubes.

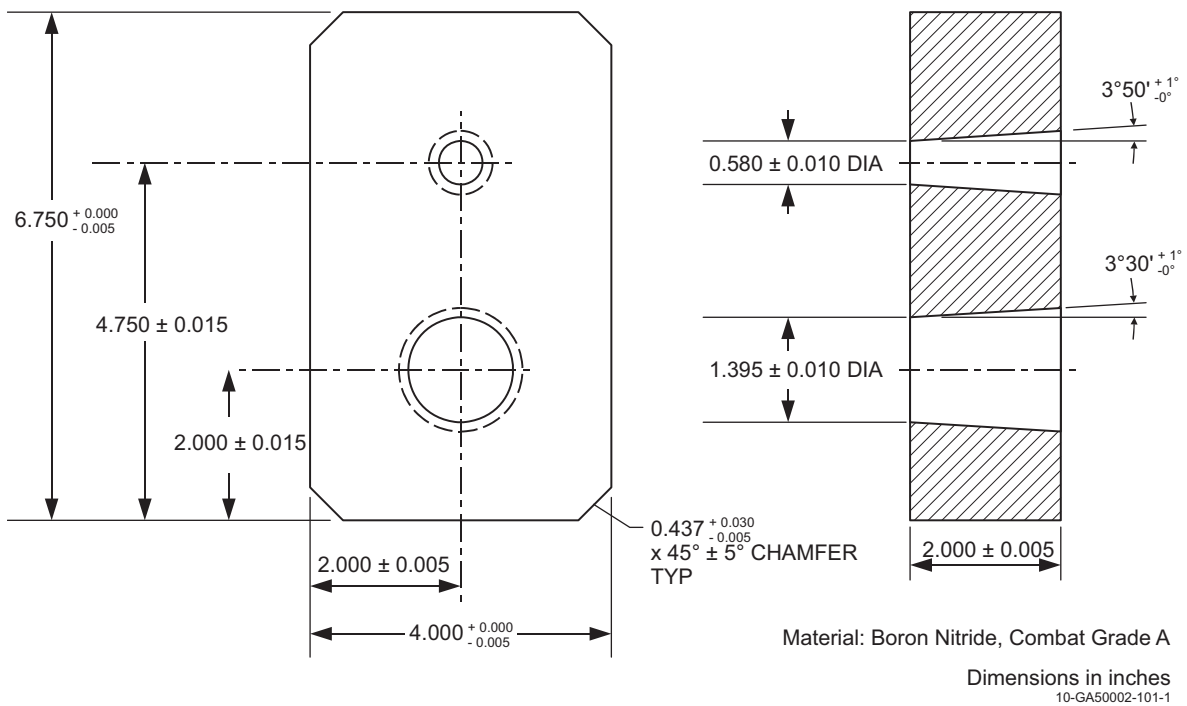

Figure 1.43. Moveable Aperture Block.

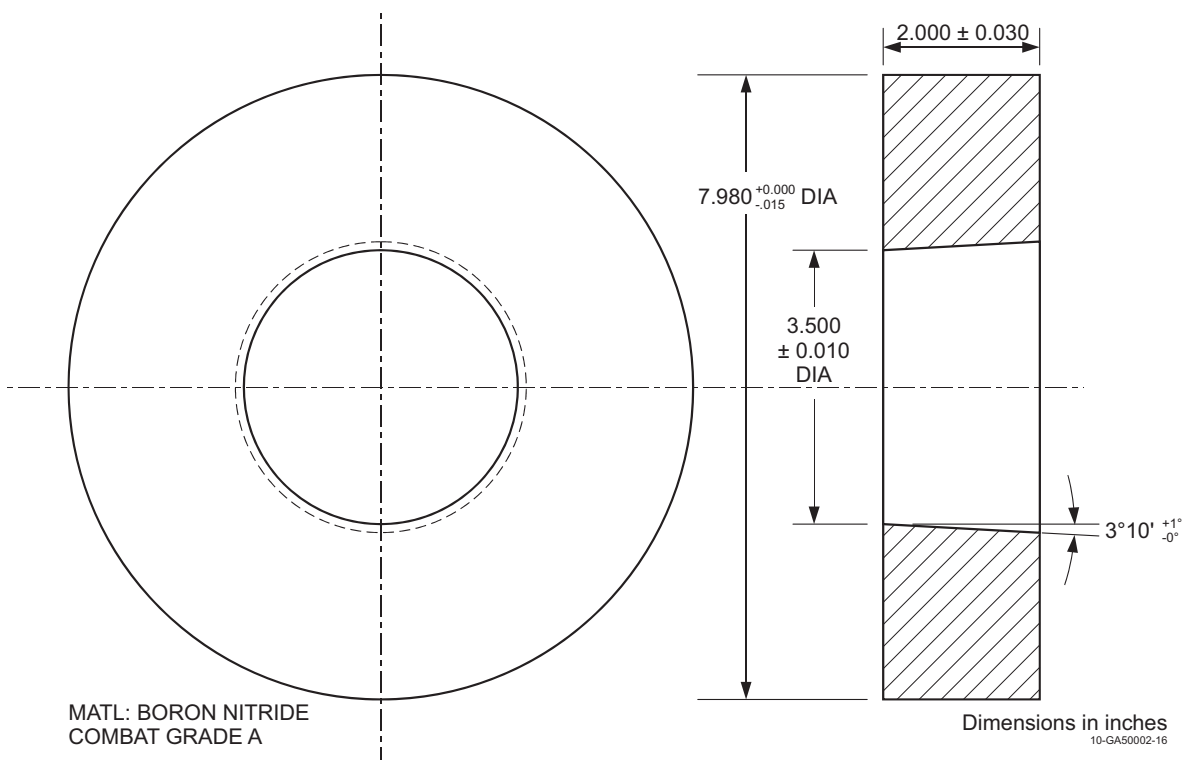

Figure 1.44. Fixed Disc Aperture Block.

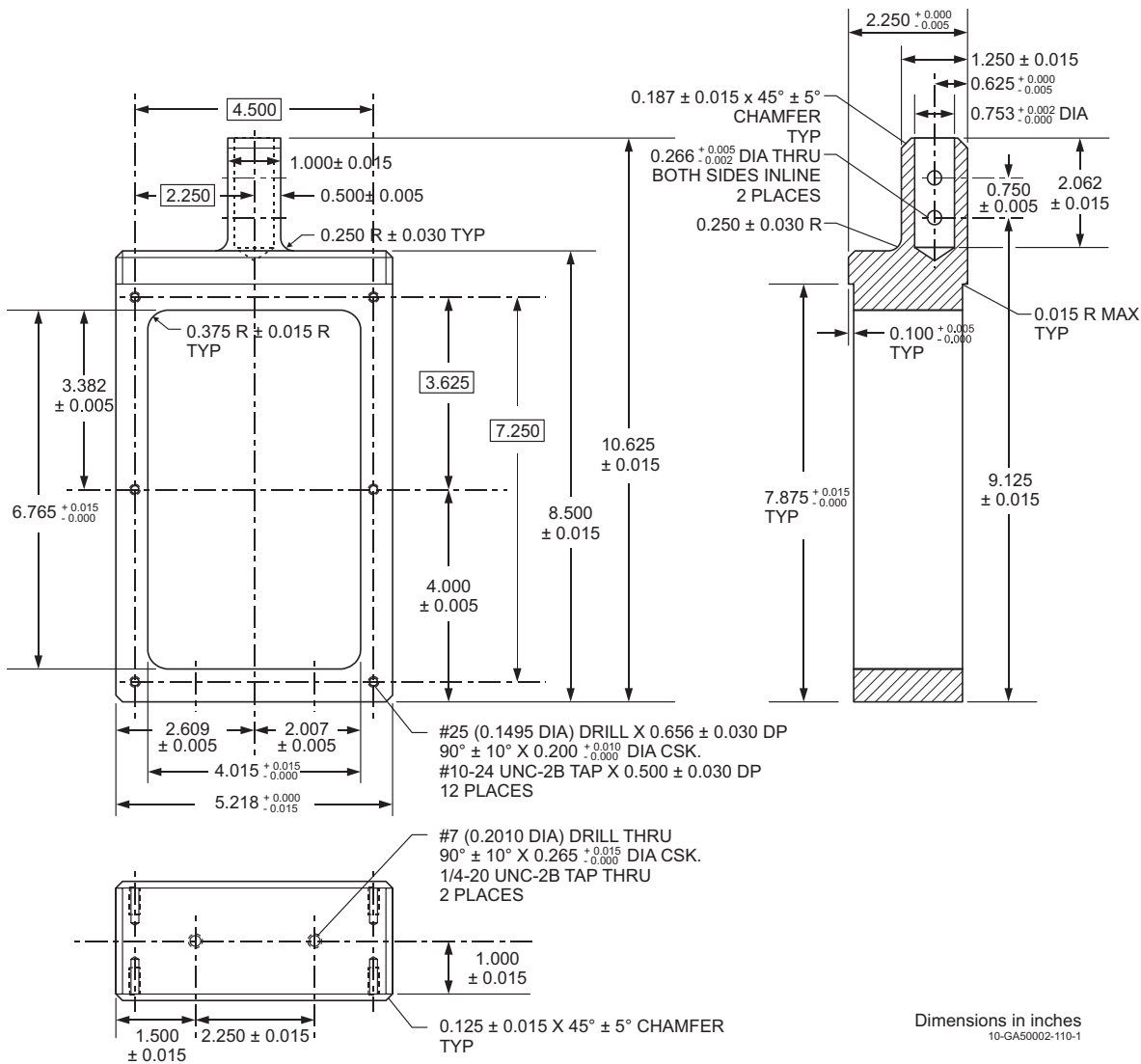

Figure 1.45a. Aperture Block Frame.

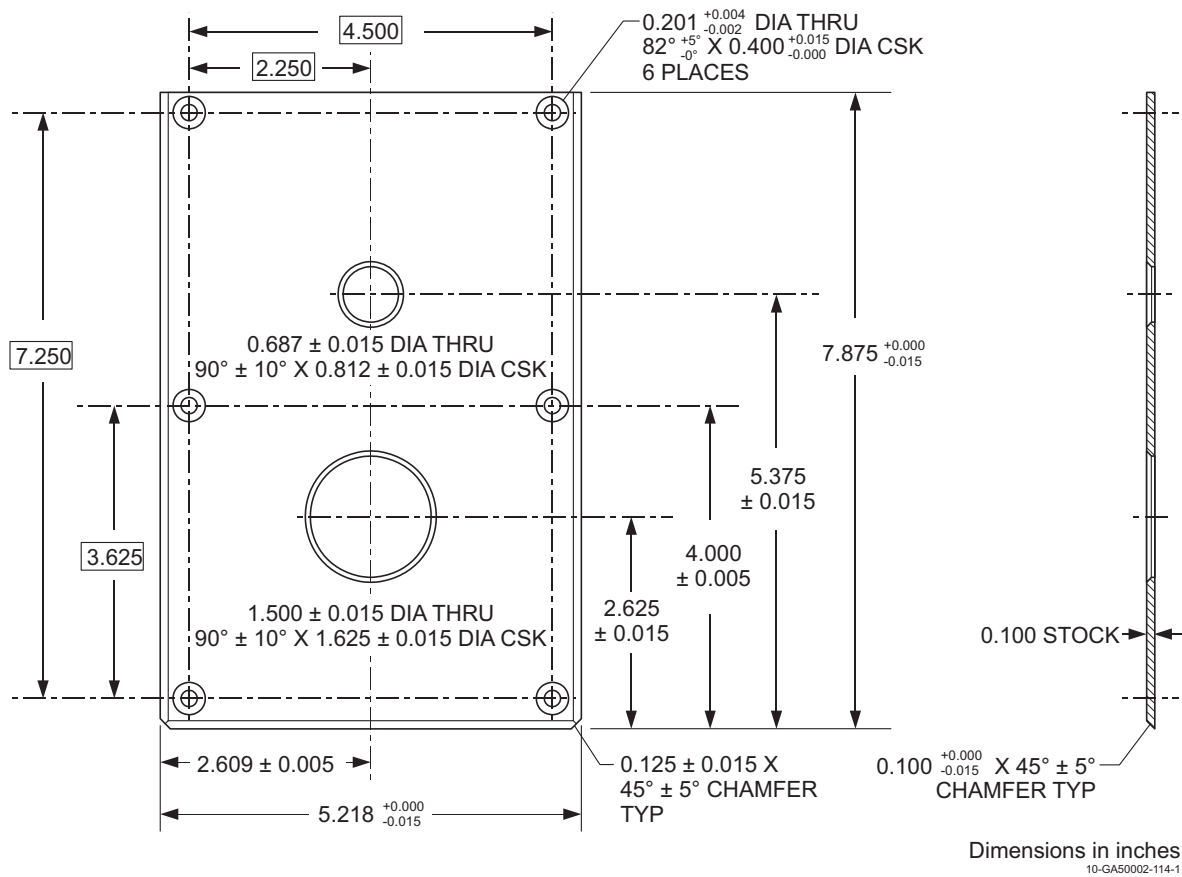

Figure 1.45b. Aperture Block Front Cover.

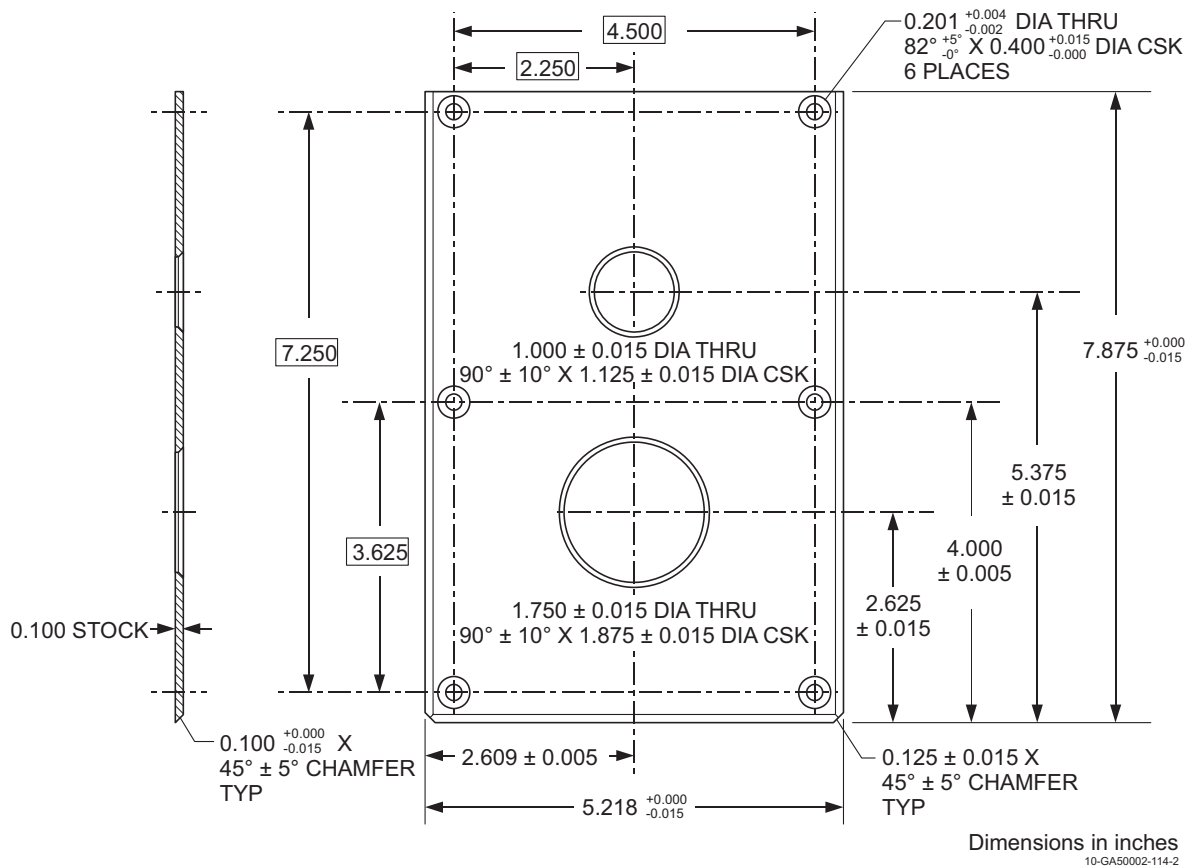

Figure 1.45c. Aperture Block Rear Cover.

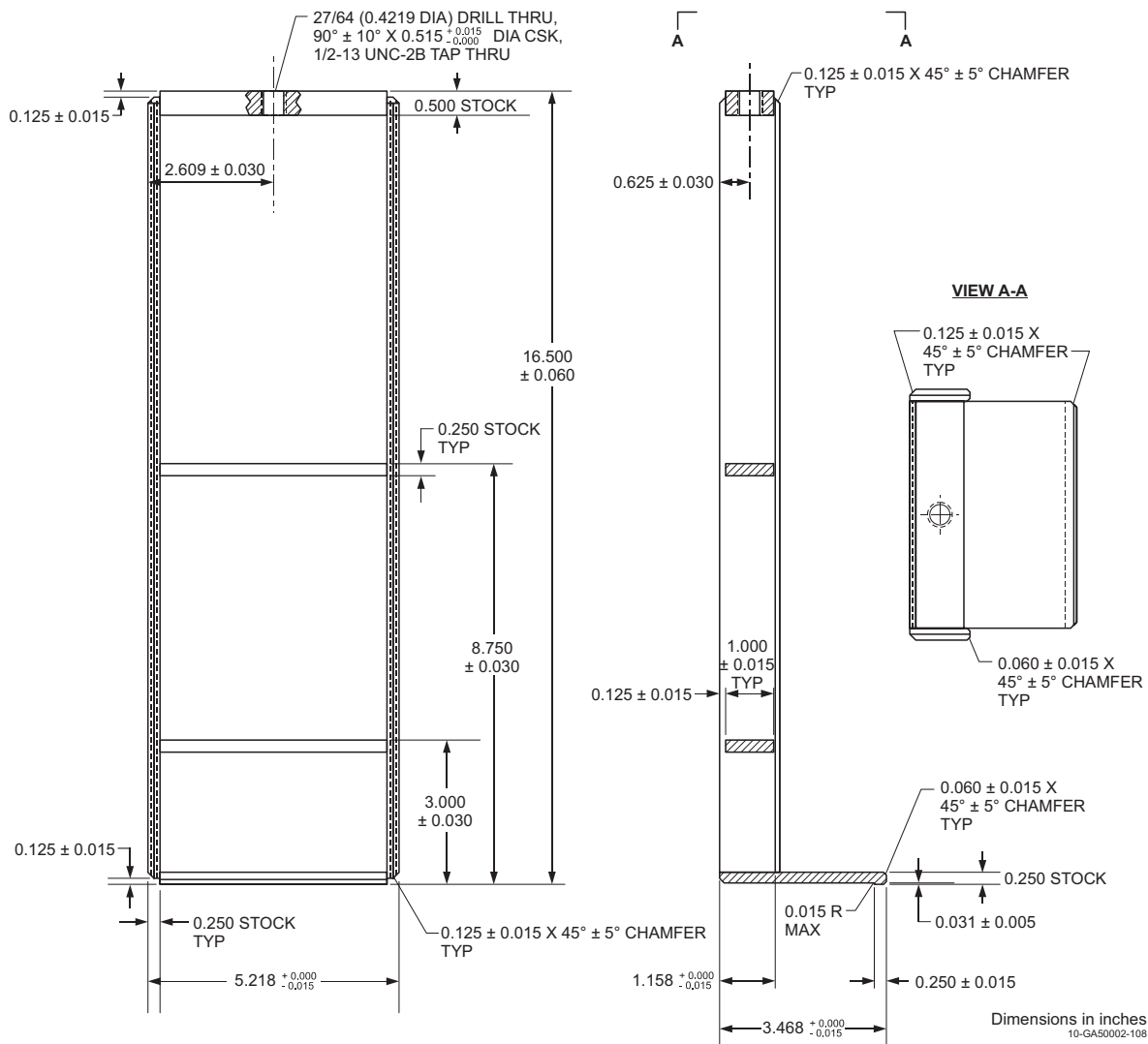

Figure 1.46. Aperture Block Guide.

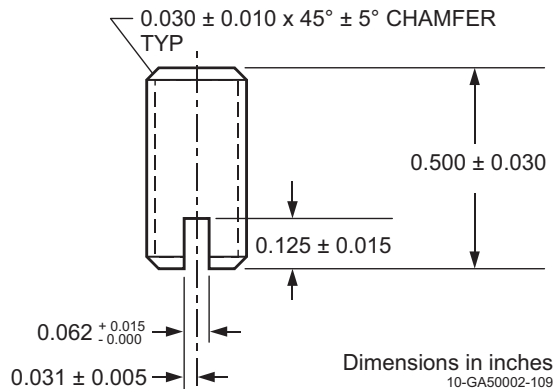

Figure 1.47. Aperture Block Adjusting Screw.

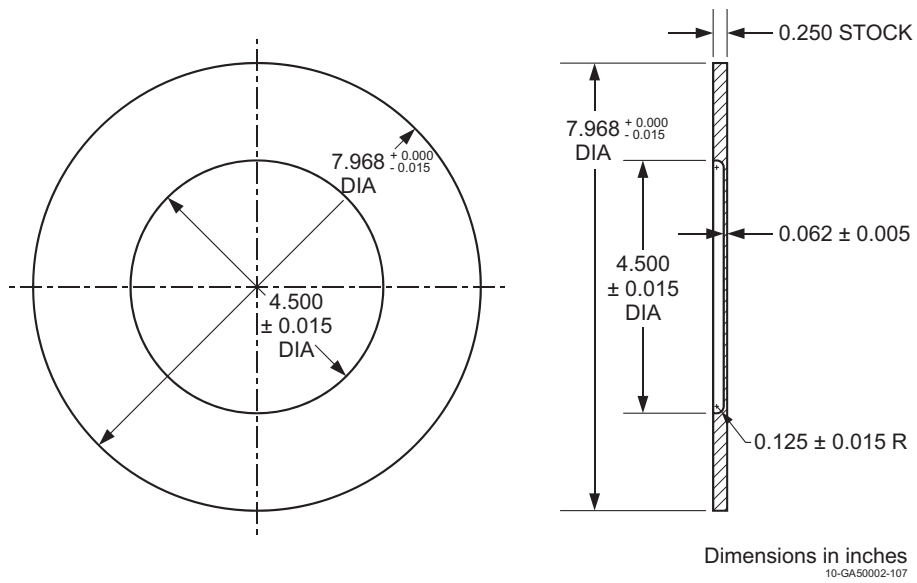

Figure 1.48. Lower Tube Seal Plate.

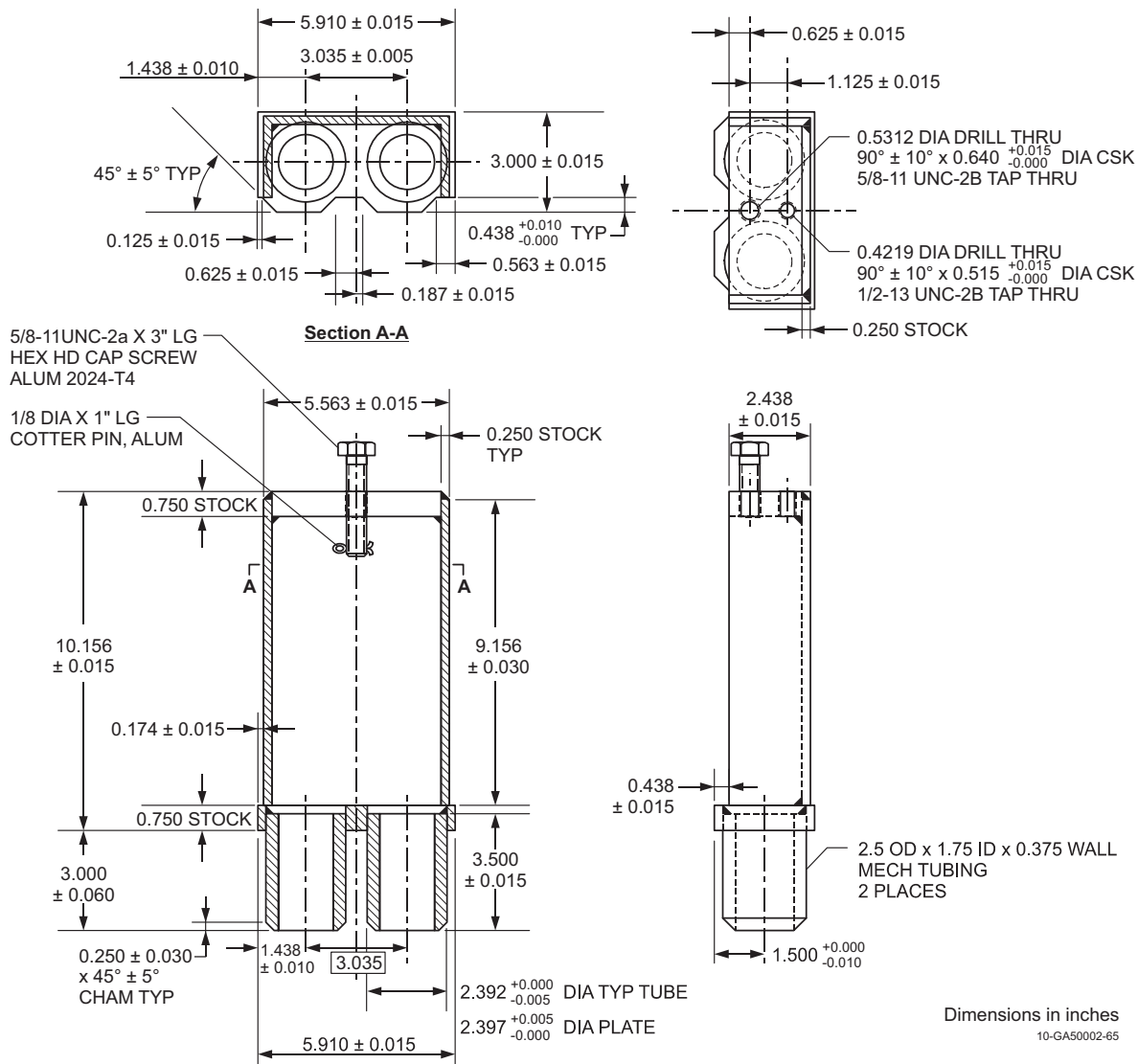

Figure 1.49. Beam Tube Support.

Water Hole (Irradiation Position)

A water hole is provided as an irradiation experimental position (Grid position C-4 SW in Figure 6). It may eventually contain the experiment irradiation section of a pneumatic transfer system. A control rod guide tube (Figure 1.35) is currently located in the position to aid in the alignment of experiment samples. The guide tube was empty (except for water) during the approach to critical and initial core measurements.

Start-Up Source

The NRAD reactor uses a start-up source to produce a measurable reactor power level during startup. It is a 5 Ci AmBe source in a sealed stainless steel cylindrical container that is 1.3 in. (3.302 cm) long and 0.8 in. (2.032 cm) in diameter. Internal dimensions of the source are not available. The source is mounted in a special graphite reflector assembly (Figure 1.50) and emits $\sim 1 \times 10^7$ neutrons/sec.^a The source was initially received on 5/10/1968 and was provided by Dayton Laboratory – Monsanto Research Corporation (currently Solutia Inc.).

The graphite block in Figure 1.50 replaces the typical graphite block in Figure 1.37 for a completed reflector assembly (Figure 1.51). The graphite reflector assembly containing the AmBe source is located in position F-3 of the NRAD core (Figure 1.6).

The start-up source is located within the graphite reflector assembly in the SE quadrant of the block approximately 14.125 in. (35.8775 cm) from the top of the graphite. The portions of the block not filled with pins and tie rods are filled with water. The source is placed within a source tube (Figure 1.52) with a cap (Figure 1.53). A wire rope is attached to the source tube cap so that it can be pulled out and moved around the tank. A special top assembly (Figure 1.54) is used to accommodate source placement in the graphite element.

The startup source is left in place during NRAD operations. It is only removed from the core to verify the source range instrument is operational before going to power. The source is swung off to the side of the tank to verify that log power decreases, and then reinstalled into its original position.

^a “NRAD Reactor Fuel Core Conversion,” DSA-005-NRAD-ADD-3 rev. 0, Idaho National Laboratory (April 2, 2009). [This reference is not available for public release.]

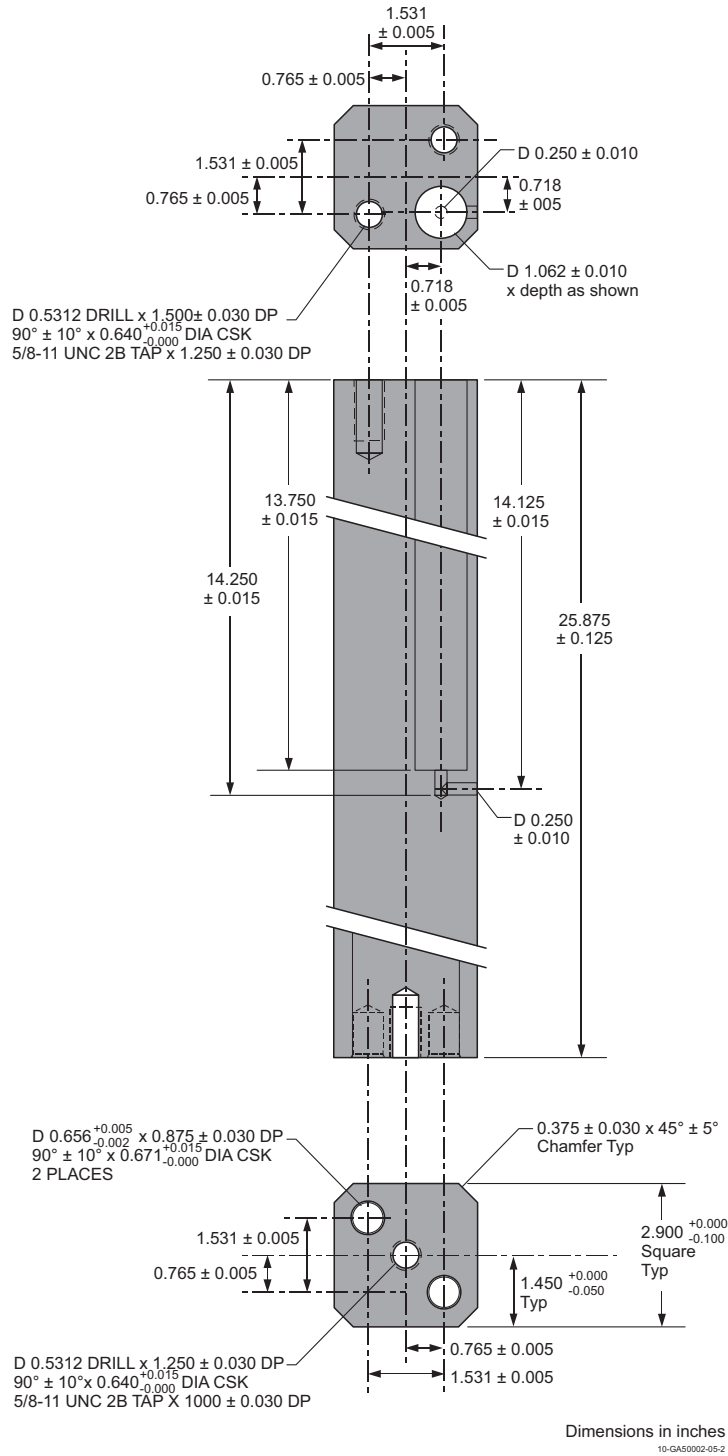

Figure 1.50. Graphite Reflector Block for Start-Up Source.

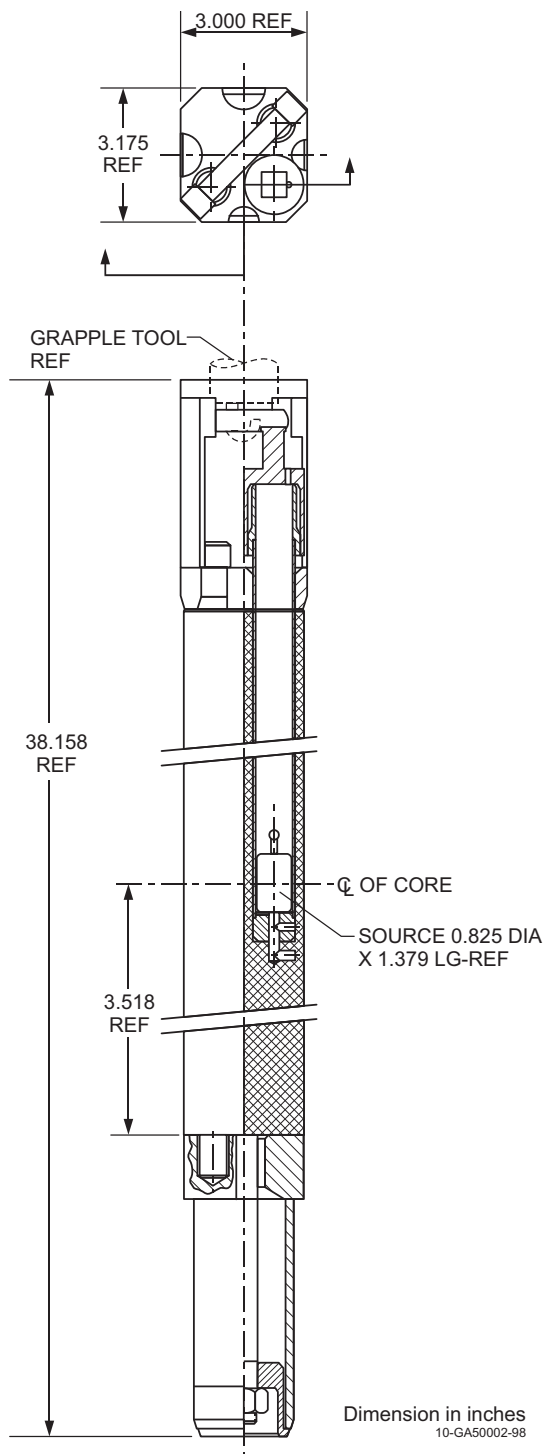

Figure 1.51. Graphite Element with Source Assembly.

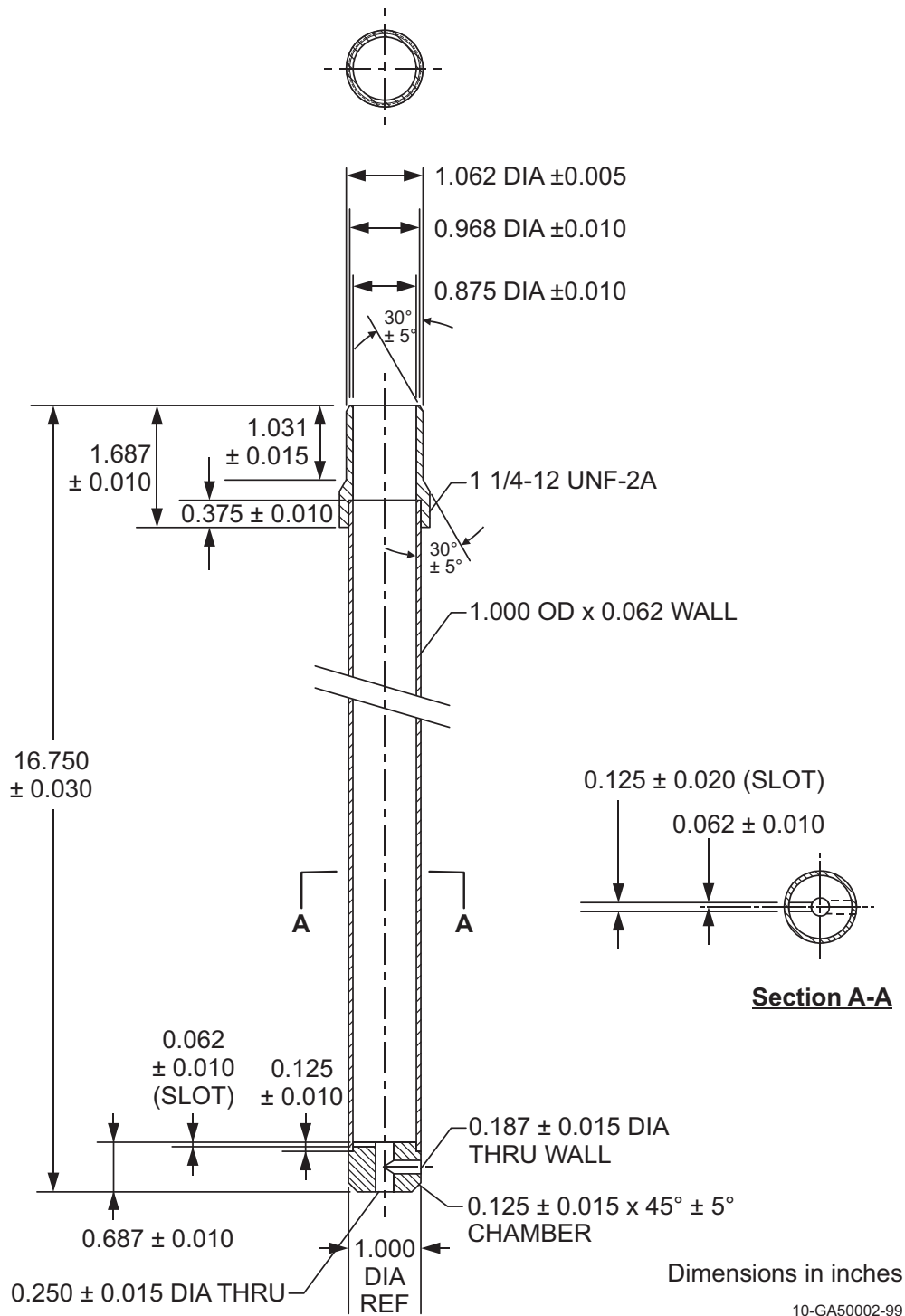

Figure 1.52. Source Tube.

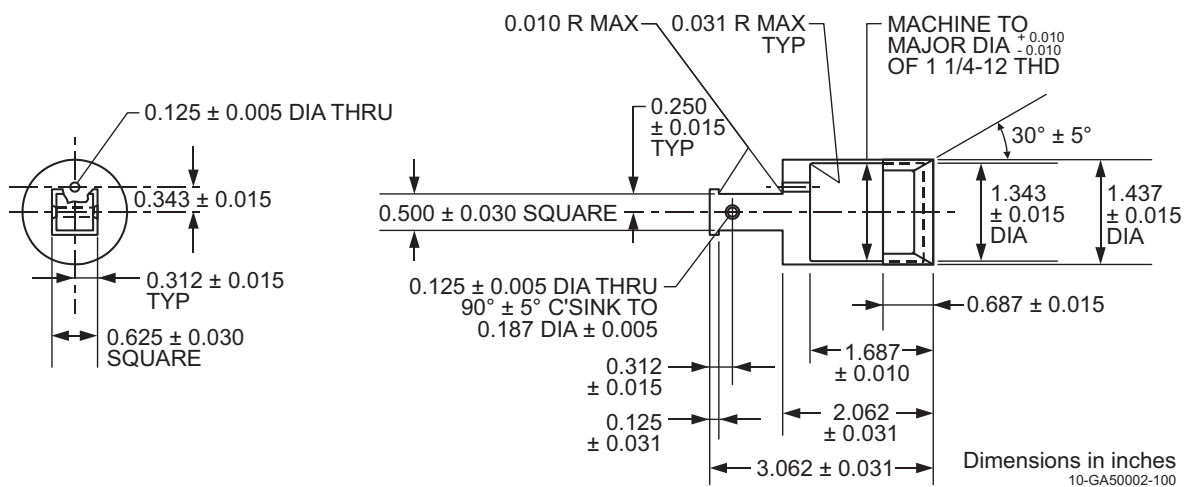

Figure 1.53. Source Tube Cap.

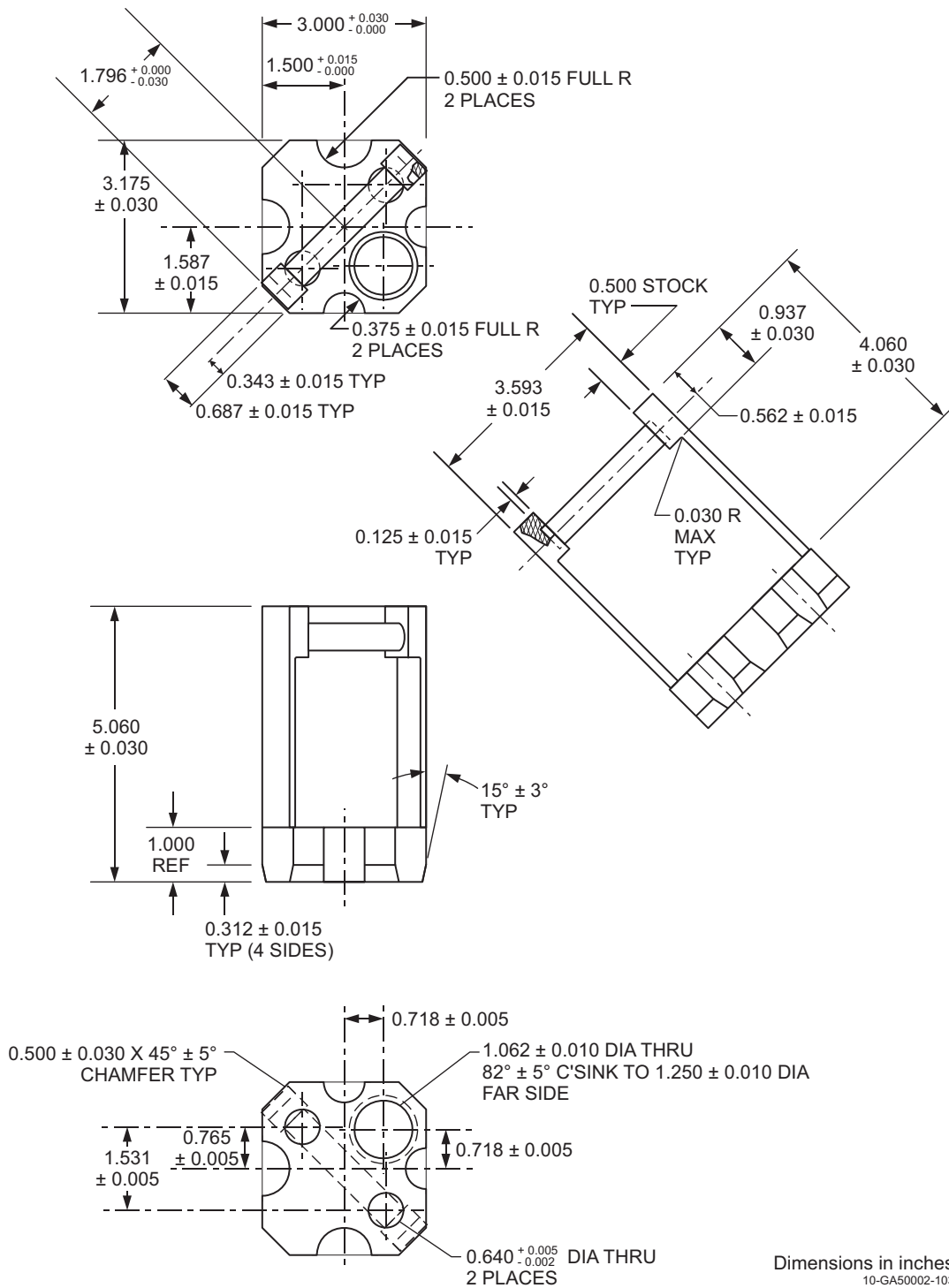

Figure 1.54. Top Assembly for Graphite Element with Source Assembly.

Detectors

The pool detectors are located to the south and north of the reactor core, near the edge of the pool (Figures 1.1 and 1.6). They consist of one linear, one log, and two safety channels. Horizontal and vertical placement of these detectors within the tank is shown with detail in Figures 1.55 and 1.56, respectively.

The wide-range (10 decade) log-power channel is a fission-chamber detector that provides indication of power and period from source level to 120% of design power. It uses both counting and Campbelling techniques to give an accurate log-power indication with very little gamma background error. Period measurements are from -30 s to +3 s over the full power range.^a

Two power-level-safety channels provide indication of reactor power from 0.001% to 120% of design power using uncompensated ion-chamber-type detectors.^a

The linear-power channel uses an all-solid-state multirange picoammeter that obtains a current signal from a compensated ion chamber. Depending on the gamma background level, this channel can measure power over most of the operating range of the reactor.^a

Detector power levels were calibrated on April 1, 2010 as part of the NRAD reactor startup procedures.^b

^a "HFEF/N Neutron Radiography Facility System Design Description," W0170-0004-SA rev. 2, Idaho National Laboratory (June 1, 1978). [This reference is not available for public release.]

^b "Startup Report for the NRAD Reactor," 911195 rev. 0, GA Project 39296, TRIGA Reactor Division of General Atomics (November 4, 2010). [This reference is not available for public release.]

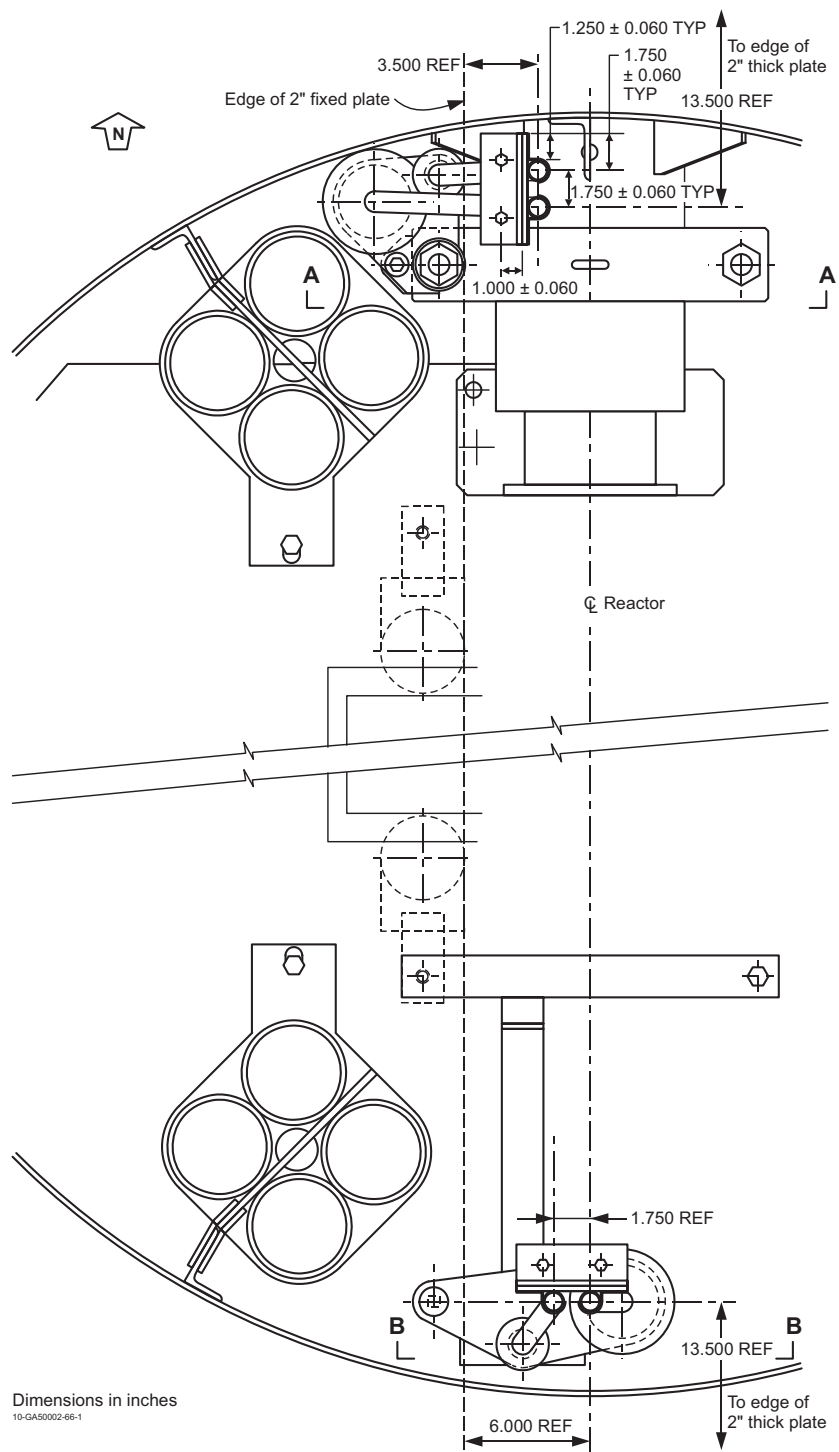

Figure 1.55. Horizontal Detector Placement in NRAD Tank.

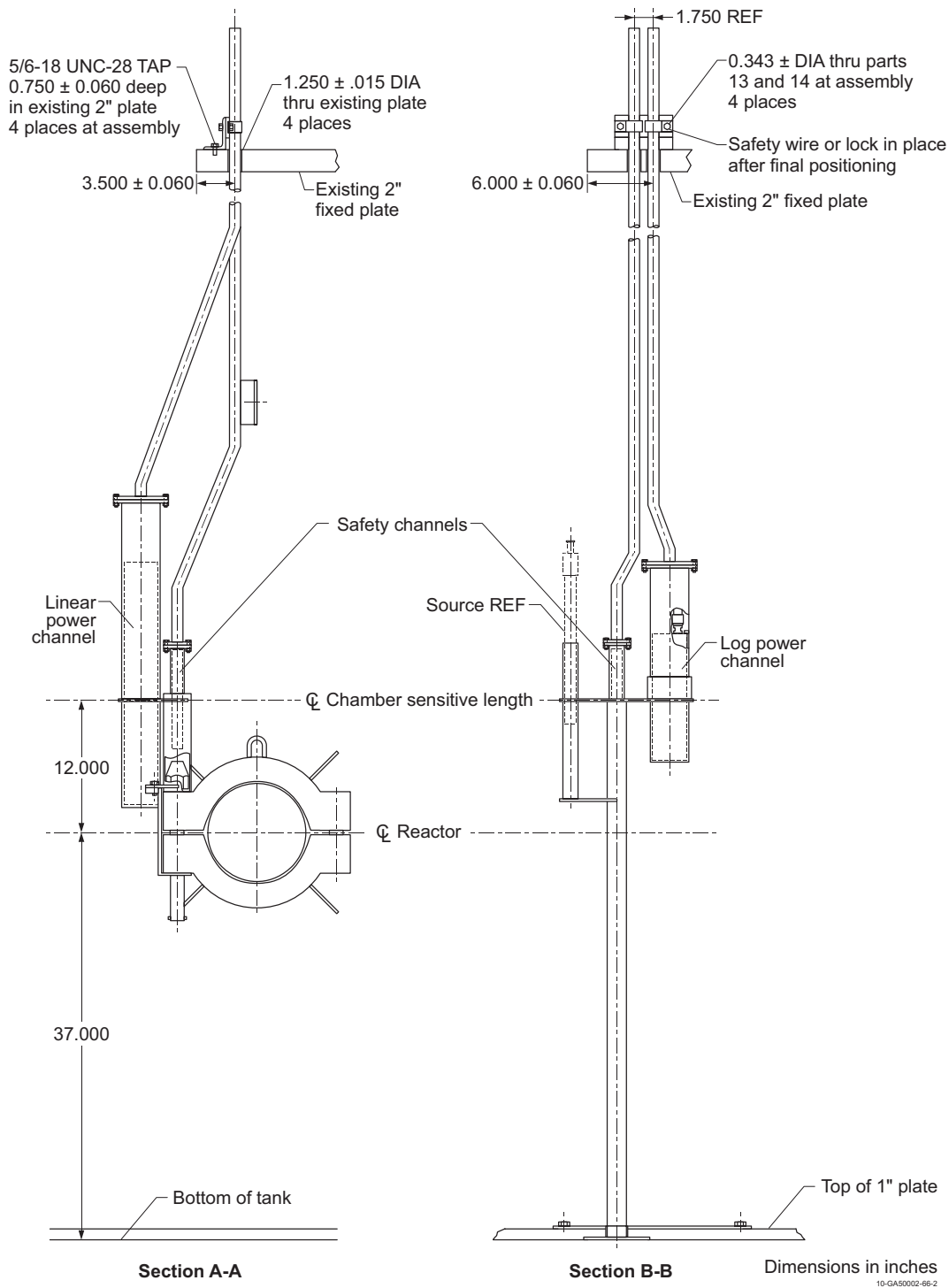

Figure 1.56. Vertical Detector Placement in NRAD Tank.

Dry Tubes

Dry tubes can be placed around the periphery of the core to allow for samples to be irradiated without getting them wet. Dry tubes were not installed during the initial critical measurements of the NRAD core. When dry tubes are used, they are typically placed in the corners of the core, as shown in position F-1 NE in Figure 1.6.

Dry tubes are aluminum pipes open at the top with an inside diameter of 1.5625 in. (3.96875 cm) and a thickness of 0.125 in. (0.3175 cm). The pipe extends from the grid plate attachment hardware to approximately 4 in. (10.16 cm) above the tank waterline. When installed in the F-1 NE position, it rests against the 90° angle formed by the graphite blocks in positions E-1 and F-2, effectively displacing a column of water just outside the reactor core. Experiments are lowered into the tube using a variety of holders.^a

The dry tube is stuck to a guide tube fitting to close the bottom of the pipe and attach it into a grid plate adapter. It is slightly cantered against the graphite blocks in the adjacent positions to wedge it into the core; friction counteracts the buoyancy effects.^b

1.1.2.3 Experimental Procedure

Fuel loading information for the NRAD core follows the initial startup plan provided by General Atomics^c and adapted by the NRAD staff.^d As-built fuel data, and physical placement of fuel clusters in the core, are found in Appendices D and E, respectively. Actual measurements taken during the start-up of the NRAD LEU core are recorded in another General Atomics report.^e The approach to critical measurements are also included in Appendix E.

Fission chamber counts and period measurements were used to monitor for criticality and the power of the core. The NRAD reactor is considered critical when the power level is sustained at 50 W, the regulating rod position is stable, and the period is infinite. The linear power channel also monitors the power level during the measurement of the just-critical state.^f

Initial criticality with 56 fuel elements (Figure 1.57) was achieved on March 19, 2010. The shim rods were fully withdrawn and the regulating rod height was 817 ± 1 units (12.255 ± 0.015 in. or 31.1277 ± 0.0381 cm). Temporary start-up detector chambers were placed next to the reflector during this experiment in positions A-1 and A-6 during startup (see bottom left and top left corners of photo in Figure E.2). These detectors were later removed.

On March 31, 2010, critical rod height and control rod reactivity measurements in the 56 element core configuration were re-performed both with and without the two startup detectors. The regulating rod height at critical was 775 ± 1 units (11.625 ± 0.015 in. or 29.5275 ± 0.0381 cm) vs. the measurement of 817 units (12.255 in. or 31.1277 cm) with the detector chambers next to the reflector. Control rod worth

^a Personal communication with Ken Schreck at HFEF (January 1, 2011).

^b Personal communication with Ken Schreck at HFEF (January 12, 2011).

^c "Neutron Radiography Reactor Analysis and Support: Startup Plan for the NRAD Reactor, Final Report," 911183 rev. 1, GA Project 39296, TRIGA Reactor Division of General Atomics (January 13, 2010). [This reference is not available for public release.]

^d "Startup Plan for the NRAD Reactor Final Report," PLN-3285 rev. 3, Idaho National Laboratory (August 2010). [This reference is not available for public release.]

^e "Startup Report for the NRAD Reactor," 911195 rev. 0, GA Project 39296, TRIGA Reactor Division of General Atomics (November 4, 2010). [This reference is not available for public release.]

^f Personal communication with Ken Schreck at HFEF (September 29, 2010).

measurements, core excess reactivity, and shutdown margin were determined for this configuration (see Section 1.4).

The operational core of 60 fuel elements (Figure 1.58), at a power of 50 W, went critical on March 31, 2010, with both shim rods fully withdrawn and the regulating rod withdrawn 536 ± 1 units (8.04 ± 0.015 in. or 20.4216 ± 0.0381 cm). The core cold excess reactivity was $\$1.19$. Control rod worth measurements, core excess reactivity, and shutdown margin were determined for this configuration (see Section 1.4).

Additional power calorimetric measurements (see Section 1.5) were performed on April 1, 2010. Approximately 2 hours were spent at each of the power data points: 0.1, 1, 10, 50, 100, 200, and 250 kW. At the end of the run, the regulating rod was withdrawn 882 ± 1 units (13.23 ± 0.015 in. or 33.6042 ± 0.0381 cm). At full operational power, 250 kW, arriving quickly from a cold, clean state, the regulating rod was initially withdrawn 860 ± 1 units (12.9 ± 0.015 in. or 32.766 ± 0.0381 cm) on June 6, 2010. Xenon poison buildup due to extended operations at elevated power are the primary cause for the difference of 22 units (0.33 in. or 0.8382 cm) in the regulating rod position at these two full power measurements. Core excess reactivity was also determined at full power.

Additional reactivity worth measurements were performed for the removal of graphite reflector block assemblies to determine their worth prior to the termination of core startup procedures (see Section 1.4). Control rod worth measurements were performed after each block removal to determine the change in core excess reactivity. Then the graphite reflector was replaced.

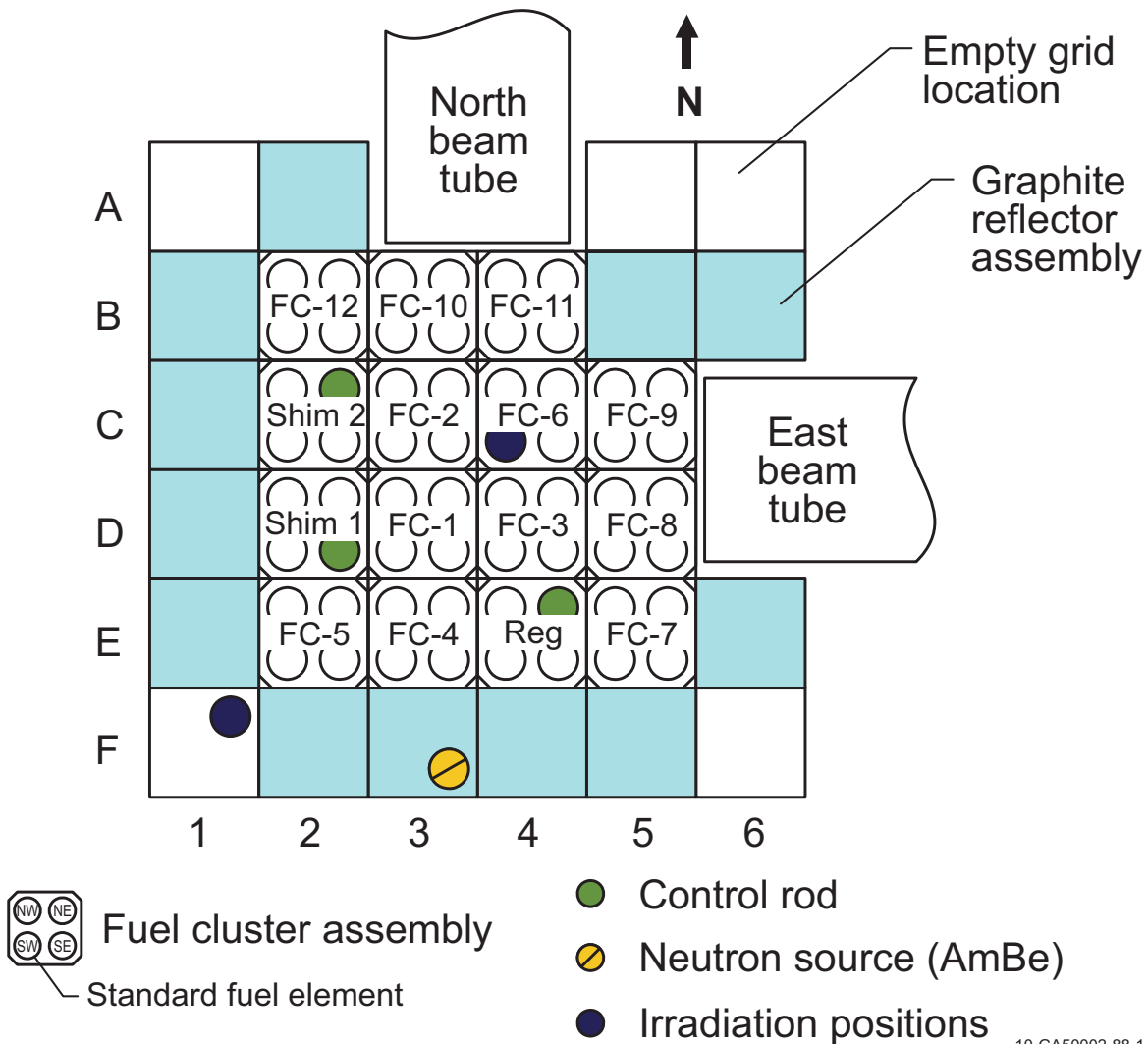

10-GA50002-88-1

Figure 1.57. Initial Core Critical Configuration (56 Fuel Elements).

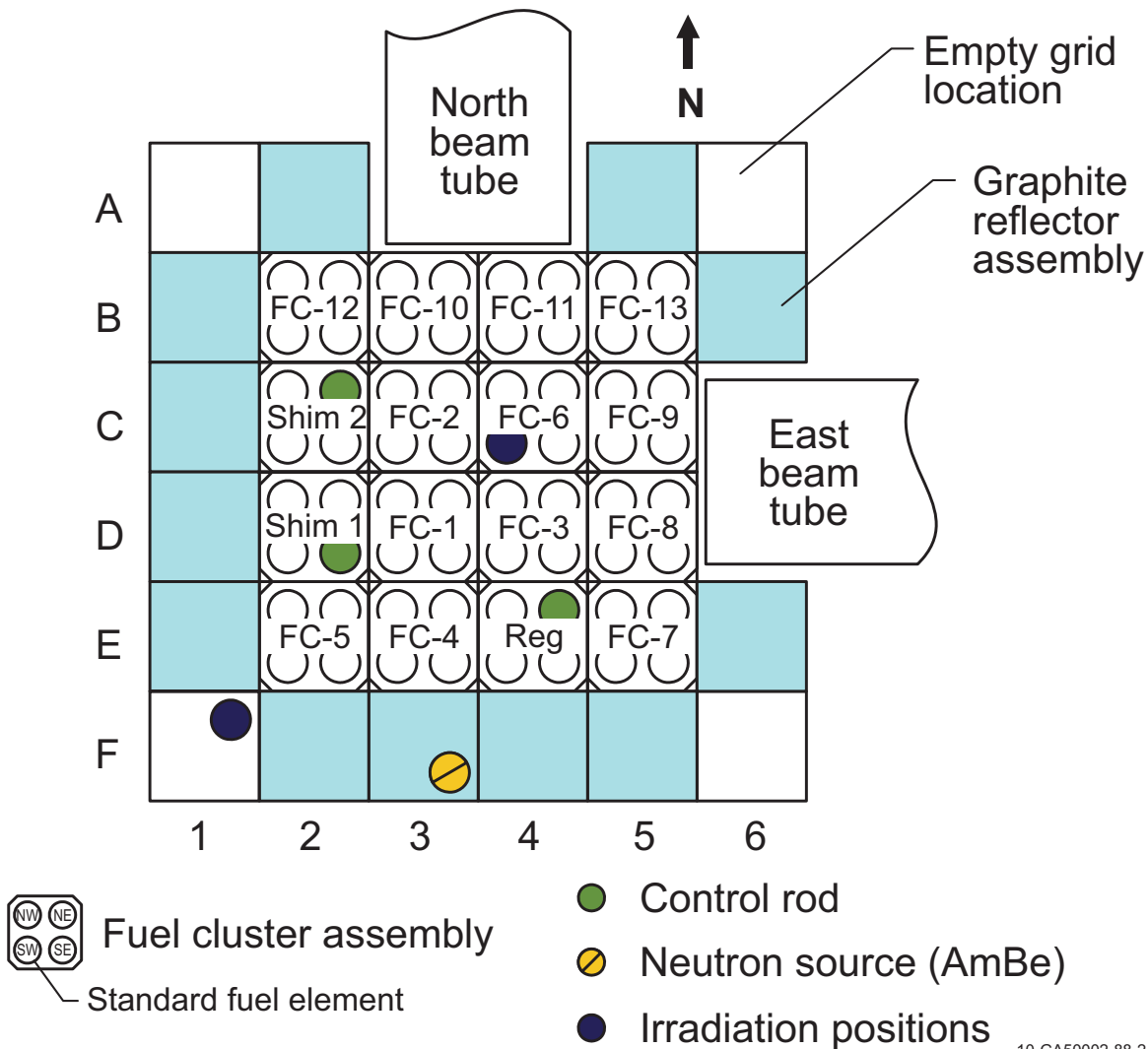

10-GA50002-88-2

Figure 1.58. Fully Loaded Core Critical Configuration (60 Fuel Elements).

1.1.3 Material Data

1.1.3.1 Facility Description

Site and Facility

The rock layer below the HFEF basement is composed of natural lava rock.

The concrete is magnetite aggregate concrete with a density of about 220 lb/ft³ (3524 kg/m³) with additional steel plates and borated polyethylene to reduce radiation levels in adjacent rooms.^a

The concrete surrounding the reactor tank contains 120 lb/yd³ (131 kg/m³) of boron frit.^b

Reactor Containment

The reactor tank is constructed from welded aluminum 6061-T6.^c

Non-Nuclear Components

The overflow and coolant system piping is comprised of aluminum 6061-T6.

Moderator/Coolant

The tank water temperature was between 26.0 and 26.2 °C during fuel loading for the initial critical with 56 fuel elements. A single thermistor, located approximately 1 ft (~30.48 cm) below the surface of the tank water, is used to measure water temperature. It is nonlinear, very accurate, and calibrated to a tenth of a degree. Two additional thermistors are located before and after the coolant water heat exchanger to measure coolant temperature during power operations. They are calibrated to a hundredth of a degree. Full power operation is limited to 39 °C. Startup temperatures are typically at 26 °C and at-power operations are typically performed at 37°C.

For the initial critical with 60 elements the tank water temperature was 27.5 °C; the tank water temperature was slightly elevated due to several days operating at low power.

The water in the NRAD tank goes through several deionizers to remove impurities. The water chemistry is monitored for conductivity and radioactivity content.

1.1.3.2 Reactor Core

Core Support Structure

The core support structure and core mounting pad are composed of aluminum 6061-T6. They are bolted together with cap screws also composed of aluminum 6061-T6.

^a "NRAD Safety Analysis Report," DSA-005-NRAD rev. 5, Idaho National Laboratory (April 2, 2009). [This reference is not available for public release.]

^b "HFEF/N Neutron Radiography Facility System Design Description," W0170-0004-SA rev. 2, Idaho National Laboratory (June 1, 1978). [This reference is not available for public release.]

^c "NRAD Reactor Fuel Core Conversion," DSA-005-NRAD-ADD-3 rev. 0, Idaho National Laboratory (April 2, 2009). [This reference is not available for public release.]

Grid Plate Assembly

The grid plate assembly is composed of aluminum 1100. It is bolted to the support structure with aluminum 6061-T6 nuts and bolts. The skirt on the four sides of the grid plate is also aluminum 6061-T6. The dowel pins used to align the cluster assemblies are stainless steel 304.

Fuel Cluster Assembly

A cluster of four fuel elements contains approximately 592 ± 1 g of ^{235}U .

The locking plates and locking bolts for the upper cluster attachments are stainless steel 304 or 304L. The threaded insert used in the top assemblies is either stainless steel 303 or 18-8. The bottom cluster fitting and remaining parts of the top assembly are aluminum 6061-T6.

Fuel Elements

The TRIGA fuel elements were manufactured in 2009-2010 by TRIGA International, a joint venture between General Atomics in San Diego, California, USA, and CERCA, a subsidiary of AREVA NP in Romans-sur-Isère, France, at the CERCA Fuel Fabrication Plant. A total of 64 low enriched fuel elements (four of which are spares) were fabricated for the NRAD reactor. A summary of the as-built fuel data (Appendix D) is provided in Table 1.5.

Table 1.5. Summary of As-Built Fuel Data per Average Fuel Element (Appendix D).^(a)

Core Configuration	Initial Critical	Fully Loaded	All Elements
Number of Fuel Elements	56	60	64
Total Mass (g)	2506.4 ± 3.5	2506.5 ± 3.4	2506.8 ± 3.6
Uranium Mass (g)	749.6 ± 2.5	749.9 ± 2.7	750.2 ± 3.1
^{235}U Mass (g)	147.9 ± 0.5	148.0 ± 0.6	148.1 ± 0.7
^{235}U Enrichment (wt.%)	19.74 ± 0.01	19.74 ± 0.02	19.74 ± 0.02
U Mass Content (wt.%)	29.91 ± 0.07	29.92 ± 0.09	29.23 ± 0.10
H/Zr Ratio	1.58 ± 0.01	1.58 ± 0.01	1.58 ± 0.01
Er Content (wt.%)	0.90 ± 0.02	0.90 ± 0.02	0.90 ± 0.02
C Content (wt.%)	0.30 ± 0.01	0.30 ± 0.02	0.30 ± 0.02
Fuel Element Length (mm)	380.2 ± 0.4	380.2 ± 0.4	380.2 ± 0.4
Fuel Element Diameter (mm)	34.805 ± 0.003	34.805 ± 0.003	34.805 ± 0.003
Cladding Inner Diameter (mm)	34.894 ± 0.005	34.894 ± 0.005	34.894 ± 0.005
Fuel-Clad Difference (mm)	0.088 ± 0.005	0.089 ± 0.005	0.089 ± 0.005

(a) The uncertainty in these values is 1σ of the average population and not the average mean.

TRIGA fuel is a uranium-zirconium-hydride (UZrH_x) fuel where the uranium is dispersed in a matrix of zirconium-hydride. Typically the H/Zr ratio is ~ 1.6 . The final fuel form is accomplished by hydriding uranium-zirconium alloy fuel sections to provide intrinsic moderation. A hole is drilled through the center of the fuel section to facilitate hydriding; then a zirconium rod is placed in the hole to prevent fuel damage during reactor operations.

Fuel with an H/Zr ratio of ~ 1.6 is δ -phase, fcc hydride that allows for considerable variation in fuel temperatures without building up high internal gas pressures in the fuel element. This also eliminates the

formation of a second phase and the problem of large volume changes at higher temperatures. The absence of significant thermal diffusion of hydrogen also precludes concomitant volume changes and cracking. The dimensional changes of fuel rods due to hydrogen migration are of minor importance.^a

The uranium-zirconium alloy is cast in an induction furnace at high temperature under a controlled atmosphere. Prior to casting, all components (uranium, zirconium, erbium, and recycled material cast off from prior fuel fabrication batches) have been carefully weighed and checked. (Erbium is added in small quantities, as a burnable poison, to reduce initial core excess reactivity.) Components are melted in a graphite crucible and poured into a graphite mold to cool down to room temperature. A remelt is performed directly in the mold to improve the homogeneity and structural quality of the alloy. After cooling, the casting is removed from the mold and brought to the desired length and diameter on a lathe. Each fuel meat is then individually identified. After machining, chops (i.e. excess scrap materials that were removed during machining) are washed away to be used as recyclable material and as samples for chemical analysis. The fuel meats are then hydrided in an electrically heated furnace at high temperature under a hydrogen environment. A centerless grinder is used to bring the fuel meat to the final diameter and then the fuel meat is cleaned to remove surface defects. The fuel meat is slid into the cladding with the other fuel element components and the end fittings are welded to the clad and Helium leak tested.^b

The addition of erbium to the UZrH introduces no deleterious effects to the fuel and is not believed to segregate as it forms a metallic solution in the uranium-zirconium alloy. Erbium forms a stable hydride, remains dispersed in the alloy, and cannot migrate or segregate because its diffusion rates are very low.^a

The fuel elements are clad in stainless steel 304 with end fittings of the same material.

Typical impurities in the fuel agglomerate include carbon and hafnium in the zirconium metal and hydrogen in the erbium. There is ~0.2 wt.% Hf in the fuel. The H:Zr specification for the fuel only correlates hydrogen to zirconium and does not include the other constituents in the fuel. The raw material feed, uranium fuel from the Y-12 National Security Complex, is typically enriched to ~19.75 wt.% ²³⁵U. The molybdenum poison disc is composed of natural molybdenum and believed to be ~100% pure. The axial graphite reflectors are comprised of nuclear grade graphite, possibly PGX™ (low ash, molded graphite) or ECW™ (highly purified, extruded graphite).^c

It is believed that a total of eleven batches of uranium metal were shipped from Y-12 to CERCA to be used in the fabrication of the NRAD fuel elements.^d The fuel is assembled under ambient air conditions.

Typically the hafnium content in the zirconium is 60 ppm without a lot of variation. The carbon content in the fuel composition comes from the hydriding process in the graphite crucible. Variations in fuel content typically have very small effects on criticality. The most sensitive composition variations include hydrogen, ¹⁶⁷Er, and ²³⁵U. All manufactured fuel was within the required fuel specifications. Variation of the loading pattern for the NRAD reactor core was calculated to have at most a 0.0012 Δk_{eff} difference between the most and least reactive configurations.^e

^a M. T. Simnad, F. C. Foushee, and G. B. West, "Fuel Elements for Pulsed TRIGA Research Reactors," *Nucl. Technol.*, **28**, 31-56 (1976).

^b G. Harbonnier and J-C. Ottone, "TRIGA International: A New TRIGA Fuel Fabrication Facility at CERCA," *Proc. Test, Research, and Training Reactors (TRTR) – Annual Meeting 1997*, Newport, Oregon (October 21-24, 1997).

^c Personal communication with John M. Bolin at General Atomics (November 3, 2009).

^d Personal communication with John M. Bolin at General Atomics (October 20, 2010).

^e Presentation material with subsequent discussion at the American Nuclear Society 2010 Annual Meeting in regards to "Fuel Manufacturing Uncertainty Effect on NRAD Criticality," by H. Choi, J. Bolin, and A. Veca (June 16, 2010).

Casting sprues, rejected meats, and filings are all reprocessed at another AREVA facility and sent back to CERCA for use in new fuel fabrications. Reprocessed material must meet the Y-12 specifications (Table 1.6).^a

The nominal density of UZrH₂ fuel containing 30 wt.% uranium content is 7.24 g/cm³.^b
There is no bonding material between the cladding and fuel meat or other fuel elements components.^c

A fuel sample (~15 g) from a spare fuel element that was fabricated and shipped with the fuel elements placed in the NRAD reactor was sent to Y-12^d for further material analysis. The sample was approximately 29.828 wt.% uranium (19.75 wt.% ²³⁵U). Various tests were performed during July 7-26, 2010, to determine the complete composition of the fuel. Results from the analyses are given in Table 1.7. Because of the variability in stock material used to fabricate all the TRIGA fuel elements, this sample provides a rough estimate of the fuel composition but does not necessarily represent the exact quantity of material in all fuel elements in the NRAD reactor. Tests to measure the oxygen, nitrogen, and hydrogen content in the sample using Leco methods could not be performed as the quantities exceeded the detection capability of the instrumentation. The fuel in the spare element was prepared in the same fuel batch as the four fuel elements not used in the operational core configuration.

^a Personal communication with Eric C. Woolstenhulme at INL (April 27, 2010).

^b N. Comte, B. Thievenaz, M. Doucet, E. Torlini, and T. Pin, "TRIGA A Widely Used Fuel – Assessments, Validation and Application of Criticality Standards," *Proc. Nuclear Criticality Safety Division Topical Meeting*, Richland, Washington (September 13-17, 2009).

^c R. E. Smith, "TRIGA Fuel Summary Report," ICP/INT-05-817, Idaho Cleanup Project, Idaho National Laboratory (March 2005). [This reference is not available for public release.]

^d Y-12 National Security Complex, Analytical Chemistry, Oak Ridge, Tennessee.

Table 1.6. Y-12 Chemical Specification of Uranium Metal Supplied to Research Reactors.^(a)

Element	Units	LEU	EBC Factor	Element	Units	LEU	EBC Factor
Uranium (Metal)	wt.%	≥ 99.880		Lead	µg/gU	≤ 5.0	0.0000
U-232	µg/gU	≤ 0.002		Lithium	µg/gU	≤ 2.0	0.1469
U-234	wt.%	≤ 0.260		Magnesium	µg/gU	≤ 50.0	0.0000
U-235 (±0.20 wt.%)	wt.%	19.75		Manganese	µg/gU	≤ 24.0	0.0034
U-236	µg/gU	≤ 4600		Molybdenum	µg/gU	≤ 100.0	0.0004
Trans-U (Alpha) ^(b)	Bq/gU	≤ 100.0		Nickel	µg/gU	≤ 100.0	0.0011
Activation Products	Bq/gU	≤ 100.0		Niobium	µg/gU	TBR	0.0002
Fission Products	Bq/gU	≤ 600.0		Nitrogen	µg/gU	TBR	0.0019
Aluminum	µg/gU	≤ 150.0	0.0000	Phosphorus	µg/gU	≤ 50.0	0.0000
Arsenic	µg/gU	TBR ^(c)	0.0008	Potassium	µg/gU	TBR	0.0008
Beryllium	µg/gU	≤ 1.0	0.0000	Samarium	µg/gU	≤ 2.0	0.5336
Boron	µg/gU	≤ 1.0	1.0000	Silicon	µg/gU	≤ 100.0	0.0000
Cadmium	µg/gU	≤ 1.0	0.3172	Silver	µg/gU	TBR	0.0083
Calcium	µg/gU	≤ 100.0	0.0002	Sodium	µg/gU	≤ 25.0	0.0003
Carbon	µg/gU	≤ 350.0	0.0000	Tin	µg/gU	≤ 100.0	0.0000
Chromium	µg/gU	≤ 50.0	0.0008	Tungsten	µg/gU	≤ 100.0	0.0014
Cobalt	µg/gU	≤ 5.0	0.0089	Vanadium	µg/gU	≤ 30.0	0.0014
Copper	µg/gU	≤ 50.0	0.0008	Zinc	µg/gU	TBR	0.0002
Dysprosium	µg/gU	≤ 5.0	0.0818	Zirconium	µg/gU	≤ 25.0	0.0000
Europium	µg/gU	≤ 2.0	0.4250	Total Impurities	µg/gU	≤ 1,200	
Gadolinium	µg/gU	≤ 1.0	4.3991	Equivalent Boron Content ^{(d),(e)}		≤ 3.0	
Iron	µg/gU	≤ 250.0	0.0006				

(a) "The Y-12 Standard Specification Low Enriched Uranium Metal Supply to Research and Test Reactors," Y/GNSS/05-05, Rev. 2, BWXT Y-12, Oak Ridge, Tennessee (August 2007).

(b) Alpha activity represents measured transuranium elements: Am-241, Cm-243/-244, Np-237, Pu-238, and Pu-239/-240.

(c) TBR means that the value is "To Be Reported", when material measurements are performed.

(d) Equivalent Boron Content (EBC) factors are taken from ASTM C1233-03, "Standard Practice for Determining Equivalent Boron Contents of Nuclear Materials." EBC calculation will include B, Cd, Dy, Eu, Gd, Li, and Sm. All other EBC factors are provided for information purposes only.

(e) The limit on EBC may restrict some elements to lower values than shown in the table above.

Table 1.7. Y-12 Analysis of U-Er-Zr-H Fuel.^(a)

Component	Value	Unit of Measure	Test Method	Component	Value	Unit of Measure	Test Method
C	2930	µg/g	Carbon Leco	Er	4600	µg/gU	ICP-MS
U	296000	µg/g	Isotopic Dilution ^(b)	Eu	0.77	µg/gU	ICP-MS
U-234	0.159	wt.%		Fe	194	µg/gU	ICP-OES
U-235	19.726	wt.%		Ga	<1	µg/gU	ICP-MS
U-236	0.144	wt.%		Gd	<0.3	µg/gU	ICP-MS
U-238	79.971	wt.%		Ge	<1	µg/gU	ICP-MS
Am-241	-32	pCi/g	CT-AM-5 ^(c)	Hf	34	µg/gU	ICP-MS
Cm-243/244	0	pCi/g		Hg	<1	µg/gU	ICP-MS
Np-237	-1.5	pCi/g	CT-NP-5 ^(c)	Ho	<1.1	µg/gU	ICP-MS
Pu-238	35	pCi/g	Alpha Spectrometry ^(c)	In	<1	µg/gU	ICP-MS
Pu-239/240	34	pCi/g		Ir	<1	µg/gU	ICP-MS
Th-228	280	pCi/g	Alpha Spectrometry ^(c)	K	22	µg/gU	ICP-MS
Th-230	42	pCi/g		La	<1	µg/gU	ICP-MS
Th-232	0	pCi/g		Li	<1	µg/gU	ICP-MS
U-234	3100000	pCi/g	Alpha Spectrometry ^(c)	Lu	<1.1	µg/gU	ICP-MS
U-235	150000	pCi/g		Mg	<1	µg/gU	ICP-OES
U-236	27000	pCi/g		Mn	7.7	µg/gU	HR-ICPMS
U-238	92000	pCi/g		Mo	3.4	µg/gU	ICP-MS
Ag	<55	µg/gU	ICP-MS ^(d)	Na	<5	µg/gU	ICP-OES
Al	<10	µg/gU	ICP-OES ^(e)	Nb	1.3	µg/gU	ICP-MS
As	<10	µg/gU	ICP-MS	Nd	<1	µg/gU	ICP-MS
Au	<5	µg/gU	ICP-MS	Ni	8.9	µg/gU	ICP-OES
B	<0.5	µg/gU	ICP-MS	Os	<1	µg/gU	ICP-MS
Ba	<1	µg/gU	ICP-MS	P	<22	µg/gU	ICP-MS
Be	<0.24	µg/gU	ICP-OES	Pb	<1	µg/gU	ICP-MS
Bi	<1	µg/gU	ICP-MS	Pd	2.5	µg/gU	ICP-MS
Ca	<5	µg/gU	ICP-OES	Pr	<1	µg/gU	ICP-MS
Cd	<1	µg/gU	ICP-OES	Pt	<1	µg/gU	ICP-MS
Ce	<1	µg/gU	ICP-MS	Rb	<1	µg/gU	ICP-MS
Co	<1	µg/gU	ICP-OES	Re	<1	µg/gU	ICP-MS
Cr	21.8	µg/gU	ICP-OES	Rh	<1	µg/gU	ICP-MS
Cs	<1	µg/gU	ICP-MS	Ru	<1	µg/gU	ICP-MS
Cu	3.1	µg/gU	ICP-OES	Sb	<2	µg/gU	ICP-MS
Dy	0.8	µg/gU	ICP-MS	Sc	<525	µg/gU	ICP-MS

Table 1.7 (cont'd.). Y-12 Analysis of U-Er-Zr-H Fuel.

Component	Value	Unit of Measure	Test Method
Se	<1	µg/gU	ICP-MS
Si	<15	µg/gU	ICP-OES
Sm	<0.31	µg/gU	ICP-MS
Sn	<2	µg/gU	ICP-MS
Sr	<1	µg/gU	ICP-MS
Ta	<1	µg/gU	ICP-MS
Tb	<2.4	µg/gU	ICP-OES
Te	<60	µg/gU	ICP-MS
Th	<2.2	µg/gU	ICP-MS

Component	Value	Unit of Measure	Test Method
Ti	19	µg/gU	ICP-OES
Tl	<2.2	µg/gU	ICP-MS
Tm	<1.1	µg/gU	ICP-MS
V	<1	µg/gU	HR-ICPMS
W	<25	µg/gU	ICP-MS
Y	<5	µg/gU	ICP-OES
Yb	<1.1	µg/gU	ICP-MS
Zn	<1	µg/gU	ICP-OES
Zr	730000	µg/gU	ICP-MS

- (a) Due to the % levels of Zr, extreme effort was required to overcome the interferences inherent to each technique in such a complex measurement.
- (b) The g/g 2-sigma relative uncertainty is typically within 0.2% and the absolute difference for ²³⁵U wt.% is typically within 0.025% for HEU.
- (c) The 2-sigma uncertainty for most of the radioisotope measurements is approximately the same as the reported value in the table. The 2-sigma uncertainty in the uranium alpha spectrometer measurements is approximately one order of magnitude less than the value reported in the table.
- (d) Quadrupole ICSP-MS.
- (e) Three separate analysis runs were performed.

Material samples were sent to Evans Analytical Group® (EAG) Labs for compositional analysis. A total of six samples were evaluated: graphite reflector block (Table 1.14), axial graphite reflector (Table 1.8), plating on molybdenum poison disc (Table 1.9), molybdenum poison disc (Table 1.10), stainless steel end fitting (Table 1.11), and zirconium rod (Table 1.12). These samples, except for the sample from the graphite reflector block, were analyzed from the same spare fuel element that was used for the fuel pellet material analysis. The samples were analyzed from April 16-21, 2010, using glow discharge mass spectrometry (GDMS). This process uses the sample as a cathode in a low pressure (~100 Pa) gas discharge or plasma (typically argon). Positive gas ions are accelerated towards the sample surface with energies of hundreds to thousands of eV, which results in the erosion and atomization of the upper atomic layers of the sample. The neutral species escape the cathode surface, diffuse into the plasma, and are ionized for mass spectrometry analysis. This method allows for high sensitivity, ease of calibration, and flexibility in sample analysis, and depth profiling for most samples (excludes volatile samples, organic materials, and polymers) with full periodic table coverage.^a

The Zr samples were filed and etched so that no cross-contamination from the stainless steel saw would occur. All samples were analyzed twice with five replicates during each analysis. The data were extremely stable during both analyses. Samples were also plasma-etched during the analysis.^b

^a SHIVA Technologies, 6707 Brooklawn Parkway, Syracuse, New York 13211, <http://www.eaglabs.com/>.

^b Personal communication with Timothy Alex West at EAG Labs (April 29, 2010).

Table 1.8. GDMS Analysis of Axial Graphite Reflector.

Element	ppm (wt.)	Element	ppm (wt.)	Element	ppm (wt.)
Li	< 0.05	Ga	< 0.01	Nd	< 0.05
Be	< 0.05	Ge	< 0.05	Sm	< 0.01
B	0.35	As	< 0.05	Eu	< 0.01
C	Matrix	Se	< 0.05	Gd	< 0.01
N	--	Br	< 0.1	Tb	< 0.01
O	--	Rb	< 0.05	Dy	< 0.01
F	< 0.1	Sr	< 0.05	Ho	< 0.01
Na	< 0.05	Y	< 0.05	Er	< 0.01
Mg	< 0.05	Zr	< 0.05	Tm	< 0.01
Al	< 0.05	Nb	< 0.05	Yb	< 0.01
Si	0.75	Mo	< 0.05	Lu	< 0.01
P	< 0.1	Ru	< 0.05	Hf	< 0.01
S	0.92	Rh	< 0.01	Ta	< 100
Cl	0.24	Pd	< 0.05	W	< 0.05
K	< 0.1	Ag	< 0.05	Re	< 0.01
Ca	< 0.05	Cd	< 0.05	Os	< 0.01
Sc	< 0.01	In	< 0.05	Ir	< 0.01
Ti	< 0.01	Sn	< 0.05	Pt	< 0.01
V	< 0.01	Sb	< 0.05	Au	< 0.1
Cr	< 0.5	Te	< 0.05	Hg	< 0.1
Mn	< 0.01	I	< 0.01	Tl	< 0.05
Fe	< 0.01	Cs	< 0.05	Pb	< 0.05
Co	< 0.01	Ba	< 0.05	Bi	< 0.05
Ni	< 0.01	La	< 0.05	Th	< 0.05
Cu	< 0.05	Ce	< 0.05	U	< 0.05
Zn	< 0.05	Pr	< 0.05		

Table 1.9. GDMS Analysis of Plating on Molybdenum Disc.

Element	ppm (wt.)	Element	ppm (wt.)	Element	ppm (wt.)
Li	< 0.01	Ga	< 0.05	Nd	< 0.01
Be	< 0.01	Ge	< 0.1	Sm	< 0.01
B	< 0.01	As	0.35	Eu	< 0.01
C	Binder	Se	< 0.1	Gd	< 0.01
N	--	Br	< 0.01	Tb	< 0.01
O	--	Rb	< 0.05	Dy	< 0.01
F	< 0.01	Sr	< 0.5	Ho	< 0.01
Na	5	Y	< 0.1	Er	< 0.01
Mg	0.45	Zr	< 0.1	Tm	< 0.01
Al	0.55	Nb	< 0.5	Yb	< 0.01
Si	2.7	Mo	Matrix	Lu	< 0.01
P	0.75	Ru	< 0.05	Hf	< 0.01
S	3.3	Rh	< 0.05	Ta	< 10
Cl	0.2	Pd	< 0.1	W	130
K	~ 30	Ag	< 0.5	Re	0.15
Ca	2.5	Cd	< 10	Os	< 0.05
Sc	< 0.005	In	< 0.05	Ir	< 0.05
Ti	< 10	Sn	0.25	Pt	< 0.05
V	1.1	Sb	1.5	Au	< 0.05
Cr	4.3	Te	< 0.05	Hg	< 0.05
Mn	0.43	I	< 0.01	Tl	< 0.05
Fe	15	Cs	< 0.05	Pb	< 0.05
Co	0.15	Ba	15	Bi	< 0.05
Ni	1.3	La	1.1	Th	< 0.005
Cu	2.5	Ce	0.03	U	0.04
Zn	< 0.05	Pr	< 0.01		

Table 1.10. GDMS Analysis of Molybdenum Disc.

Element	ppm (wt.)	Element	ppm (wt.)	Element	ppm (wt.)
Li	< 0.01	Ga	< 0.05	Nd	< 0.01
Be	< 0.01	Ge	< 0.1	Sm	< 0.01
B	< 0.01	As	0.35	Eu	< 0.01
C	--	Se	< 0.1	Gd	< 0.01
N	--	Br	< 0.01	Tb	< 0.01
O	--	Rb	< 0.05	Dy	< 0.01
F	< 0.01	Sr	< 0.5	Ho	< 0.01
Na	0.77	Y	< 0.1	Er	< 0.01
Mg	0.29	Zr	< 0.1	Tm	< 0.01
Al	0.33	Nb	< 0.5	Yb	< 0.01
Si	1.3	Mo	Matrix	Lu	< 0.01
P	0.27	Ru	< 0.05	Hf	< 0.01
S	0.59	Rh	< 0.05	Ta	< 10
Cl	< 0.01	Pd	< 0.1	W	120
K	~ 20	Ag	< 0.5	Re	0.11
Ca	1.1	Cd	< 10	Os	< 0.05
Sc	< 0.005	In	< 0.05	Ir	< 0.05
Ti	< 10	Sn	0.13	Pt	< 0.05
V	1.1	Sb	1.1	Au	< 0.05
Cr	3.3	Te	< 0.05	Hg	< 0.05
Mn	0.43	I	< 0.01	Tl	< 0.05
Fe	8.5	Cs	< 0.05	Pb	< 0.05
Co	0.13	Ba	15	Bi	< 0.05
Ni	1.1	La	0.79	Th	< 0.005
Cu	2.5	Ce	0.02	U	0.04
Zn	< 0.05	Pr	< 0.01		

Table 1.11. GDMS Analysis of Stainless Steel End Fitting.

Element	ppm (wt.)	Element	ppm (wt.)	Element	ppm (wt.)
Li	< 0.01	Ga	16	Nd	< 0.005
Be	< 0.01	Ge	20	Sm	< 0.005
B	2.5	As	35	Eu	< 0.005
C	--	Se	< 0.1	Gd	< 0.005
N	--	Br	< 0.1	Tb	< 0.005
O	--	Rb	< 0.5	Dy	< 0.005
F	< 0.01	Sr	< 0.2	Ho	< 0.005
Na	< 0.01	Y	< 0.05	Er	< 0.005
Mg	1.8	Zr	1.8	Tm	< 0.005
Al	12	Nb	110	Yb	< 0.005
Si	~ 0.4 wt.%	Mo	~ 0.3 wt.%	Lu	< 0.005
P	260	Ru	< 0.1	Hf	< 0.01
S	22	Rh	< 0.05	Ta	< 1
Cl	< 0.05	Pd	< 0.05	W	160
K	< 0.01	Ag	< 0.5	Re	0.25
Ca	0.5	Cd	< 0.1	Os	0.09
Sc	< 0.005	In	< 0.5	Ir	0.09
Ti	20	Sn	55	Pt	< 0.1
V	~ 0.1 wt.%	Sb	8.9	Au	< 0.05
Cr	Matrix	Te	< 0.05	Hg	< 0.1
Mn	Matrix	I	< 0.05	Tl	< 0.05
Fe	Matrix	Cs	< 0.01	Pb	0.31
Co	800	Ba	< 0.05	Bi	< 0.01
Ni	Matrix	La	< 0.01	Th	< 0.005
Cu	~ 0.3 wt.%	Ce	< 0.05	U	< 0.005
Zn	0.5	Pr	< 0.005		

Table 1.12. GDMS Analysis of Zirconium Rod.

Element	ppm (wt.)	Element	ppm (wt.)	Element	ppm (wt.)
Li	< 0.005	As	0.04	Sm	< 0.005
Be	< 0.005	Se	< 0.05	Eu	< 0.005
B	0.05	Br	< 0.05	Gd	< 0.005
F	< 1	Rb	< 0.05	Tb	< 0.005
Na	< 0.01	Sr	< 0.05	Dy	< 0.005
Mg	< 0.005	Y	< 0.05	Ho	< 0.005
Al	40	Zr	Matrix	Er	< 0.005
Si	7.1	Nb	0.61	Tm	< 0.005
P	0.79	Mo	2.2	Yb	< 0.005
S	0.25	Ru	< 0.05	Lu	< 0.005
Cl	0.23	Rh	< 0.05	Hf	55
K	< 0.1	Pd	< 0.5	Ta	< 5
Ca	< 0.05	Ag	< 0.5	W	0.12
Sc	< 5	Cd	< 0.5	Re	< 0.005
Ti	1.7	In	< 0.1	Os	< 0.005
V	0.43	Sn	0.49	Ir	< 0.005
Cr	120	Sb	< 0.05	Pt	< 0.05
Mn	14	Te	< 0.05	Au	< 0.05
Fe	~ 0.15 wt.%	I	< 0.1	Hg	< 0.05
Co	1.1	Cs	< 0.005	Tl	< 0.01
Ni	63	Ba	< 0.005	Pb	0.36
Cu	13	La	< 0.005	Bi	0.16
Zn	0.41	Ce	< 0.005	Th	< 0.001
Ga	2.2	Pr	< 0.005	U	0.07
Ge	< 0.05	Nd	< 0.005		

Control Rods

The B₄C poison material is hot pressed to a minimum density of 2.415 g/cm³. The tubing material of the control rods is aluminum 6061-T6.^a The extension rod, control rod connection fittings, and dowels are all aluminum 6061-T6. The bottom adapter fitting of the control rod guide tube is built from stainless steel 304 or 304L. The dowel pin used to fix the guide tube to this fitting is stainless steel 18-8. All other material in the control rod guide tube is aluminum 6061-T6.

Design drawings for the B₄C material specify a minimum density of 2.48 g/cm³ with a boron content of 78.0 ± 1.0 wt.% with the naturally occurring isotope fraction of ¹⁰B (18.5 ± 0.2 wt.%). The boron to carbon atom ratio in the finished pieces is 4.00 ± 0.15.

Graphite Reflector Assembly

The graphite in the reflector assemblies is considered nuclear/reactor grade.^b

Six graphite block samples were sent to IMR Test Labs Material Analysis Services^c to analyze the density of the graphite reflector blocks. The samples were measured between May 6-7, 2010, using ASTM C838-96 (2005)^d methods for bulk density determination from mass and dimension measurements at room temperature. A graphite reflector block (similar to the one shown in Figure 1.39) was cut into sections. Pieces from three different axial locations of the block were cut out; at each axial location, a sample was taken from the side and center, such that homogeneity of the graphite density could be established. Results are shown in Table 1.13.

Table 1.13. Density Analysis of Graphite Reflector Block.

Sample ID	Density (kg/m ³)
A-Side	1,570
A-Center	1,570
B-Side	1,560
B-Center	1,580
C-Side	1,560
C-Center	1,580

The results for the GDMS analysis, as described previously for fuel element components, of the graphite reflector block from EAG Labs is in Table 1.14.

The top and bottom assembly adapters are aluminum 6061-T6 and the associated hardware are aluminum 2011-T3 (also known as Toolrite 2011TM).

^a “HFEF/N Neutron Radiography Facility System Design Description,” W0170-0004-SA rev. 2, Idaho National Laboratory (June 1, 1978). [This reference is not available for public release.]

^b L. M. Montierth, “Criticality Safety Evaluation for the NRAD Core Conversion,” INL/INT-07-13231 rev. 1, Idaho National Laboratory (September 2008). [This reference is not available for public release.]

^c 131 Woodsedge Drive, Lansing Business & Technology Park, Lansing, New York 14882, <http://www.imrtest.com/>.

^d ASTM C838-96, Standard Test Method for Bulk Density of As-Manufactured Carbon and Graphite Shapes.

Table 1.14. GDMS Analysis of Graphite Reflector Block.

Element	ppm (wt.)	Element	ppm (wt.)	Element	ppm (wt.)
Li	< 0.05	Ga	< 0.01	Nd	< 0.05
Be	< 0.05	Ge	< 0.05	Sm	< 0.01
B	0.75	As	< 0.05	Eu	< 0.01
C	Matrix	Se	< 0.05	Gd	< 0.01
N	--	Br	< 0.1	Tb	< 0.01
O	--	Rb	< 0.05	Dy	< 0.01
F	< 0.1	Sr	0.51	Ho	< 0.01
Na	0.15	Y	< 0.05	Er	< 0.01
Mg	1.4	Zr	0.44	Tm	< 0.01
Al	1.3	Nb	< 0.05	Yb	< 0.01
Si	81	Mo	< 0.05	Lu	< 0.01
P	1.8	Ru	< 0.05	Hf	< 0.01
S	50	Rh	< 0.01	Ta	< 100
Cl	2.3	Pd	< 0.05	W	< 0.05
K	< 0.1	Ag	< 0.05	Re	< 0.01
Ca	23	Cd	< 0.05	Os	< 0.01
Sc	0.07	In	< 0.05	Ir	< 0.01
Ti	18	Sn	< 0.05	Pt	< 0.01
V	29	Sb	< 0.05	Au	< 0.1
Cr	< 0.5	Te	< 0.05	Hg	< 0.1
Mn	0.12	I	< 0.01	Tl	< 0.05
Fe	55	Cs	< 0.05	Pb	< 0.05
Co	< 0.01	Ba	< 0.05	Bi	< 0.05
Ni	3.5	La	< 0.05	Th	< 0.05
Cu	< 0.05	Ce	< 0.05	U	< 0.05
Zn	< 0.05	Pr	< 0.05		

Beam Ports

The beam filter tubes are aluminum 6061-T6. The North tube is backpressure filled with helium gas and the East tube contains air. The beam tube support is also constructed from aluminum 6061-T6. The hex head cap screw attached to the top of the beam tube support is aluminum 2024-T4.

The East wet package can contain either air or helium and is currently operated with air. The aperture housings are maintained with a helium overpressure between 75 to 85 inches of water (19 to 21 kPa), which also includes the beam tube between the tank wall and the aperture housing. Outside the reactor tank on the east side, the beam line is filled with air all the way to the sample tube coming down from the HFEF main cell. The main cell sample tube is filled with Argon. The beam tube outside of the reactor tank up to the north radiography cell is filled with helium.^a

The aperture assembly and source tube extending to the tank wall is aluminum 6061-T6. The aperture blocks are Combat Grade A boron nitride from The Carborundum Co., Graphite Products Division. The source tube inner lining is rolled Boral and the tube is filled with helium gas.

Water Hole (Irradiation Position)

The water hole position (within a control rod guide tube) in the core did not contain any experiments, detectors, or equipment, and thus was only filled with tank water.

Start-Up Source

The startup source is comprised of AmBe material in a sealed stainless steel container. The source tube and source tube cap are aluminum 6061.

Detectors

The pool detectors are placed in aluminum housings; the specific type of aluminum is not reported.

Dry Tubes

The aluminum 6061 dry tubes were not installed during the start-up measurements of the NRAD core.

1.1.4 Temperature Data

The tank water temperature was between 26.0 and 26.2 °C during fuel loading for the initial critical with 56 fuel elements. Startup temperatures are typically at 26 °C and at-power operations are typically performed at 37°C.

For the initial critical with 60 elements the tank water temperature was 27.2 °C; the tank water temperature was slightly elevated due to several days operating at low power.

1.1.5 Additional Information Relevant to Critical and Subcritical Measurements

Additional information is not available.

^a Personal communication with Ken Schreck at HFEF (April 29, 2010).

1.2 Description of Buckling and Extrapolation Length Measurements

Buckling and extrapolation length measurements were not made.

1.3 Description of Spectral Characteristics Measurements

Spectral characteristics measurements were not made.

1.4 Description of Reactivity Effects Measurements

1.4.1 Overview of Experiment

Start-up testing for the HEU/LEU fuel conversion of the NRAD TRIGA reactor began on March 9, 2010 and was completed on June 7, 2010. During this time period, measurements were performed to obtain the worth of two shim rods, one regulating rod, the shutdown margin, and the excess reactivity for both the initial core configuration (56 fuel elements) and the operational core configuration (60 fuel elements). The worths of four graphite reflector blocks and the placement of the dry tube, available for experimental use, were also measured.

On March 24, 2010, rod worth measurements were performed for the 56-fuel-element initial core configuration with temporary start-up detector chambers placed next to the reflector in positions A-1 and A-6 during startup (see bottom left and top left corners of photo in Figure E.2). These detectors were later removed and the worth measurements were repeated for the initial core configuration on March 30, 2010. Rod drops were performed for both shim rods and the partially inserted regulating rod. Positive period measurements were performed to evaluate the remaining worth of the regulating rod and the excess reactivity of the core. The shutdown margin was determined from the difference in the combined worth of the withdrawn portions of the control rods.

On March 31, 2010, the worth measurements were repeated for the 60-fuel-element operational core configuration. The shim rods were also partially inserted to allow for a full rod drop measurement of the regulating rod. The worth of the regulating rod (partial rod drop and positive period measurement) was measured again on May 17, 2010, and May 20, 2010.

The worths of four graphite reflector blocks were determined experimentally between May 12, 2010 and May 19, 2010. The measurements were performed by removing the block from the core, performing a partial regulating rod drop, assessing the core excess reactivity, and comparing the change in excess reactivity relative to the nominal 60-fuel-element operational core configuration. The block was then returned to the core prior to the removal of another block.

The worth of the experiment dry tube was assessed on July, 8, 2010, a month after the conclusion of the start-up testing, using the same method as described for measuring the worth of the graphite reflector blocks.

Numerous measurements were performed to experimentally measure the worths of various core components in both the 56- and 60-fuel-element cores. Whereas the purpose of the measurements was to obtain specific core parameters, only the desired parameters were evaluated as benchmark experiment measurements. Reactivity effects measurements evaluated include a total of fifteen measurements (six control rod worths, two shutdown margins, two core excess reactivities, four graphite reflector block worths, and the worth of the experiment dry tube); they are determined to be acceptable benchmark experiments.

Additional kinetics data pertaining to these measurements is unavailable.

1.4.2 Geometry of the Experiment Configuration and Measurement Procedure

The geometry of the core configurations and individual reactor components is provided in Section 1.1.2. Changes from the nominal configurations of the 56- and 60-fuel-elements cores and a description of the measurement procedure are provided below.

Rod worth measurements are performed according to the procedure NRAD-OI-5140A.^a A summary of the procedure is provided as follows.^b

All worth measurements are performed with the reactor critical at either 300 W for the rod drop measurements or 30 W for the positive period method. The power level is selected to allow sufficient detector range to gather the necessary information; a power that is high enough so that the instrument noise does not confuse the indication but as low as possible to limit heat generation in the reactor tank.

The reactor is brought to critical with the shim rods fully withdrawn and the regulating rod to a specific height to achieve criticality. The two shim rods are then individually dropped. The decay in the power is timed and a period is derived from the observed power decay; the reactivity necessary to produce the calculated period is obtained from a data chart in the procedure. Power is marked at three time intervals: 6, 10, and 20 seconds. The calculated three periods are averaged and the average reactivity value is assigned for that rod for the core configuration when the test is performed.

The regulating rod's reactivity is the sum of the rod drop method for that portion of the rod that is withdrawn from the core to establish criticality, and segments that are withdrawn to obtain a positive period. The rod drop portion is identical to that described for the two shim rods.

From exactly critical at 30 W, the regulating rod is withdrawn ~50 units and the power is allowed to rise. The rise in power is timed for four separate power intervals. When the last time split is obtained, the reactor is returned to critical using the two shim rods as a pair to compensate for the regulating rod in preparation for the next segment. The resulting period is calculated for each of the four timed power intervals and then averaged (the maximum power does not exceed 1 kW). The average period is used to obtain a reactivity number associated with that period and assigned to that increment of rod travel. The regulating rod continues out and the shim rods are inserted as a bank in a stepwise manner until the regulating rod is fully withdrawn. Typically, eight measurements are performed for the 60-fuel-element core. Combination of these eight positive period measurements and the partial rod drop provides the total worth of the regulating rod.

The core excess reactivity is represented by the worth of the regulating rod that remains in the core for a particular core configuration (i.e. the sum of all positive period measurements).

The shutdown margin is represented by the worth of the two shim rods and the portion of the regulating rod that is removed from the core for a given core configuration. The worth of each rod is measured individually and rod shadowing effects are assumed to be negligible within the experimental uncertainty.

The reactivity worths of the graphite blocks are the difference between the excess reactivity for the 60-fuel-element core configuration and the excess reactivity for each core configuration with a block removed.

^a R. Bryan and K. Schreck, "Verification of Shutdown Margin and Control-Rod Reactivity Measurement," NRAD-OI-5140A, Idaho National Laboratory (2006).

^b Personal communication with Ken Schreck at HFEF (May 26, 2011).

Full height rod drops of the regulating rod are performed for information and comparison to historical methods of obtaining the regulating rod worth. The shims are inserted as a bank to keep the reactor exactly critical and compensate for the regulating rod being fully withdrawn.^a

The empty dry tube reactivity was measured as $-\$0.06$ (July 8, 2010) when placed in the NE corner of the F-1 core position.^b

Table 1.15 contains the control rod calibration measurements for the 56-fuel-element core, with additional detectors adjacent to the core, performed on March 24, 2010. The repeated measurements without these detectors were performed on March 30, 2010, and the results are provided in Table 1.16. Only three positive period measurements were performed, instead of the conventional eight, due to the small quantity of core excess reactivity in the initial core configuration. Rod worth measurements for the 60-fuel-element core (March 31, 2010) are provided in Table 1.17. Repeated regulating rod measurements for the operational core on May 17 and May 20, 2010, are reported in Tables 1.18 and 1.19, respectively; individual steps in the positive period measurements were not reported. Excess reactivity measurements to determine the worths of the graphite blocks for the operational core are reported in Table 1.20; the excess reactivity for these measurements is compared with the excess reactivity for the nominal core configuration (Tables 1.18 and 1.19) to determine the worths of the graphite blocks.

Control rod positions and worths were not available for the measurement of the dry experiment tube worth. Only core excess reactivity was compared to determine the measured core worth; the control rods are not recalibrated for experiments where the worth is thought to be less than $\pm 25 \text{ } \mu$.^c

Full travel of an NRAD control rod is 15 in. (38.1 cm). The rod position indication displays 0-1000 units of travel from a down limit switch to the up limit switch, respectively. Each unit of display is equal to 0.015 in. (0.0381 cm) of rod travel. A good confidence band (3σ) for knowing the location of the control rod is ± 4 units (0.06 in., 0.1524 cm). The drive travel in the reactor room was physically measured and validated that the full travel length is 15 in. The digital position indication is calibrated at the zero, down limit, and again at 1000 units, or the upper limit, using potentiometers on the back of the reactor console. As much as -3 units to zero units at the lower limit and 999 or 1000 units at the upper limit is allowed.^d

^a Personal communication with Ken Schreck at HFEF (June 1, 2011).

^b Personal communication with Ken Schreck at HFEF (January 1, 2011).

^c Personal communication with Ken Schreck at HFEF (January 19, 2011).

^d Personal communication with Ken Schreck at HFEF (April 5-6, 2010).

Table 1.15. Control Rod Calibrations for 56-Fuel-Element Core with Detectors (March 24, 2010).

Initial Power (W)	Shim 1 Position (units)	Shim 2 Position (units)	Reg Position (units)	Reg Movement (units)	Activity	Measured Worth ($\rho\%$)	Average Worth ($\rho\%$)	
300	999	1000	818	--	Shim 1 Drop	3.10	3.09	
						3.07		
						3.09		
				--	Shim 2 Drop	2.87	2.86	
						2.89		
						2.83		
				0	Partial Reg Drop	2.23	2.26	
						2.25		
						2.31		
30	1000	1000	816	870	Positive Period	0.1150	0.2809	
	947	947	870	928		0.0964		
	911	911	928	999		0.0695		
	890	890	816	999	Total Positive Period (Excess Reactivity)			
					Total Reg Worth Shutdown Margin (Positive Period Rod)			2.54
								-8.21

Table 1.16. Control Rod Calibrations for 56-Fuel-Element Core without Detectors (March 30, 2010).

Initial Power (W)	Shim 1 Position (units)	Shim 2 Position (units)	Reg Position (units)	Reg Movement (units)	Activity	Measured Worth (ρ \$)	Average Worth (ρ \$)	
300	1000	999	776	--	Shim 1 Drop	2.95	2.92	
						2.88		
						2.92		
				--	Shim 2 Drop	2.87	2.87	
						2.88		
						2.87		
				0	Partial Reg Drop	2.15	2.18	
						2.20		
						2.19		
30	1000	1000	773	832	Positive Period	0.1429	0.3896	
	936	936	832	903		0.1345		
	894	894	903	999		0.1122		
	864	864	773	999	Total Positive Period (Excess Reactivity)			
					Total Reg Worth Shutdown Margin (Positive Period Rod)			2.57
								-7.97

Table 1.17. Control Rod Calibrations for 60-Fuel-Element Core without Detectors (March 31, 2010).

Initial Power (W)	Shim 1 Position (units)	Shim 2 Position (units)	Reg Position (units)	Reg Movement (units)	Activity	Measured Worth (ρ \$)	Average Worth (ρ \$)			
300	1000	999	536	--	Shim 1 Drop	2.84	2.83			
						2.85				
						2.80				
				--	Shim 2 Drop	3.04		2.91		
						286				
						2.83				
	704	704	999	0	Partial Reg Drop	1.28	1.28			
						1.26				
						1.30				
				0	Full Reg Drop	2.68	2.64			
						2.65				
						2.59				
30	1000	1000	536	577	Positive Period	0.1594	1.1859			
				928		625		0.1789		
				874		674		0.1778		
				830		727		0.1710		
				793		788		0.1698		
				761		855		0.1490		
				733		909		0.0834		
				719		999		0.0966		
				703		999			Total Positive Period (Excess Reactivity)	
									Total Reg Worth (Positive Period)	2.47
									Shutdown Margin (Positive Period Rod)	-7.02
				Shutdown Margin (Full Rod Drop)	-7.19					

Table 1.18. Control Rod Calibrations for 60-Fuel-Element Core without Detectors (May 17, 2010).

Initial Power (W)	Shim 1 Position (units)	Shim 2 Position (units)	Reg Position (units)	Reg Movement (units)	Activity	Average Worth (ρ\$)
300	1000	1000	537	0	Partial Reg Drop	1.2800
30			537	999	Total Positive Period (Excess Reactivity)	1.18
					Total Reg Worth (Positive Period)	2.4612
					Shutdown Margin (Positive Period Rod)	-7.02
					Shutdown Margin (Full Rod Drop)	-7.20

Table 1.19. Control Rod Calibrations for 60-Fuel-Element Core without Detectors (May 20, 2010).

Initial Power (W)	Shim 1 Position (units)	Shim 2 Position (units)	Reg Position (units)	Reg Movement (units)	Activity	Average Worth (ρ\$)
300	1000	1000	537	0	Partial Reg Drop	1.2800
30			537	999	Total Positive Period (Excess Reactivity)	1.18
					Total Reg Worth (Positive Period)	2.4609
					Shutdown Margin (Positive Period Rod)	-7.02
					Shutdown Margin (Full Rod Drop)	-7.20

Table 1.20. Graphite Block Worth Measurements for 60-Fuel-Element Core.

Date	Initial Power (W)	Shim 1 Position (units)	Shim 2 Position (units)	Reg Position (units)	Reg Movement (units)	Activity	Average Worth (ρ\$)	
5/19/2010	300	1000	1000	579	0	Partial Reg Drop	1.46	
	30			579	999	Total Positive Period	1.01	
							(Excess Reactivity)	
							Total Reg Worth (Positive Period)	2.4682
						Remove Block A-5	-0.17	
5/13/2010	300	1000	1000	656	0	Partial Reg Drop	1.7633	
	30			656	999	Total Positive Period	0.75	
							(Excess Reactivity)	
							Total Reg Worth (Positive Period)	2.5164
						Remove Block C-1	-0.43	
5/13/2010	300	1000	1000	660	0	Partial Reg Drop	1.78	
	30			660	999	Total Positive Period	0.73	
							(Excess Reactivity)	
							Total Reg Worth (Positive Period)	2.5133
						Remove Block D-1	-0.45	
5/12/2010	300	1000	1000	647	0	Partial Reg Drop	1.59	
	30			647	999	Total Positive Period	0.71	
							(Excess Reactivity)	
							Total Reg Worth (Positive Period)	2.30
						Remove Block F-4	-0.47	

1.4.3 Material Data

The materials in the core were those described in Section 1.1.3.

1.4.4 Temperature Data

The tank water temperature was between 26.0 and 26.2 °C during fuel loading for the initial critical with 56 fuel elements. Startup temperatures are typically at 26 °C and at-power operations are typically performed at 37°C.

For the initial critical with 60 elements the tank water temperature was 27.5 °C; the tank water temperature was slightly elevated due to several days operating at low power.

1.4.5 Additional Information Relevant to Reactivity Effects Measurements

Additional information is not available.

1.5 Description of Reactivity Coefficient Measurements

1.5.1 Overview of Experiment

Start-up testing for the HEU/LEU fuel conversion of the NRAD TRIGA reactor began on March 9, 2010 and was completed on June 7, 2010. During this time period, calorimetric power calibrations were performed up to 250 kW and the excess reactivity was determined at full power (250 kW) for the 60-fuel-element operational core.

On April 1, 2010, power calibrations were performed for approximately 2-hour segments at powers ranging from 0.1 to 250 kW. The regulating rod position was monitored to assess the reduction in core excess reactivity. However, due to minor xenon buildup in the core, this experiment was repeated on June 2, 2010, with approximately 6-minute time segments at each power step to observe the reduction in core excess reactivity without significant xenon buildup. The repeated measurements were used to test the linearity of the detectors for monitoring core power.

The reactivity coefficient measurements due to rising core power have not been evaluated.

1.5.2 Geometry of the Experiment Configuration and Measurement Procedure

The geometry of the core configurations and individual reactor components is provided in Section 1.1.2. Changes from the nominal configurations of the 56- and 60-fuel-elements cores described are described below.

Reactor power calibrations measurements are performed according to the procedure NRAD-OI-5160A.^a The purpose of these measurements is to calibrate and verify the power channel instrumentation used during operation and for system safety requirements. Typically, the Flow- ΔT method is used, where the primary cooling system flow and differential-pressure readings are used to calculate the reactor power.

Calculation of the heating of the tank using measured tank water temperatures is also used, but not required, to verify reactor power and nuclear-instrument calibration. A mixer is used to assist in distribution of the core heat throughout the tank water with the primary cooling system loop is closed.

Results recorded for the rise to power measurements are provided in Table 1.21. As the core power increased, the position of the regulating rod was withdrawn further from the core. The worth of the regulating rod was used to determine the effective reduction in core excess reactivity. The water temperature was monitored by the thermistor located just before the coolant water heat exchanger and the thermistor located in the reactor tank (see Section 1.1.3.1).

^a "Reactor Power Calibration," NRAD-OI-5160A, Idaho National Laboratory (2009).

Table 1.21. Summary of Calorimetric Power Calibration Measurements.^(a)

Date	Time at Power	Power (kW)	Reg Position (units)	Shim Position (units)	Core ER (ρ\$)	ER Loss (ρ\$)	Cumulative ER Loss (ρ\$)	Hot Leg T (°C)	Tank T (°C)
4/1/2010	~2 h	0.01	535	1000	1.19	0.00	0.00	--	--
	~2 h	1	537	1000	1.18	0.01	0.01	--	--
	~2 h	10	551	1000	1.13	0.05	0.06	28.6	28.6
	~2 h	50	606	1000	0.92	0.21	0.27	29.0	28.9
	~2 h	100	668	1000	0.70	0.22	0.49	33.0	32.9
	~2 h	200	786	1000	0.34	0.36	0.85	35.9	35.8
	~2 h	250	860	1000	0.17	0.17 ^(b)	1.02	37.5	37.2
6/2/2010	~6 min	0.1	537	1000	1.17	0.00	0.00	--	--
	~6 min	1	538	1000	1.17	0.00	0.00	--	--
	~6 min	10	552	1000	1.12	0.05	0.05	28.0	28 ^(d)
	~6 min	50	603	1000	0.93	0.19	0.24	28.2	28 ^(d)
	~6 min	100	661	1000	0.72	0.21	0.45	28.8	28 ^(d)
	~6 min	200	772	1000	0.38	0.34	0.79	30.8	30 ^(d)
	~6 min	250	830	1000	0.23	0.15	0.94	32.8 ^(c)	33 ^(d)

(a) ER is the abbreviation for Excess Reactivity in the core.

(b) Minor xenon buildup due to extended operations at each power level.

(c) Better measurement temperature due to tank water mixing.

(d) Decimal place for the temperature measurements was not recorded.

1.5.3 Material Data

The materials in the core were those described in Section 1.1.3.

1.5.4 Temperature Data

Water temperature measurements are reported in Table 1.21. Fuel temperature measurements were not measured.

1.5.5 Additional Information Relevant to Reactivity Coefficient Measurements

Additional information is not available.

1.6 Description of Kinetics Measurements

Kinetics measurements were not made.

1.7 Description of Reaction-Rate Distribution Measurements

Reaction-rate distribution measurements were not made.

1.8 Description of Power Distribution Measurements

Power distribution measurements were not made.

1.9 Description of Isotopic Measurements

Isotopic measurements were not made.

1.10 Description of Other Miscellaneous Types of Measurements

Other miscellaneous types of measurements were not made.

2.0 EVALUATION OF EXPERIMENTAL DATA

Monte Carlo n-Particle (MCNP) version 5-1.51 calculations were utilized to estimate the biases and uncertainties associated with the experimental results in this evaluation for the 60-fuel-element core critical configuration. MCNP 5-1.60 calculations were used for evaluation of the 56-fuel-element core critical configuration, reactivity worth calculations, and sample results provided in Section 4. MCNP is a general-purpose, continuous-energy, generalized-geometry, time-dependent, coupled n-particle Monte Carlo transport code.^a The Evaluated Neutron Data File library, ENDF/B-VII.0,^b cross section data were also used in this evaluation. The statistical uncertainty in k_{eff} and Δk_{eff} is 0.00007 and 0.00010, respectively. Calculations were performed with 1,550 generations with 100,000 neutrons per generation. The k_{eff} estimates did not include the first 50 generations and are the result of 150,000,000 neutron histories.

2.1 Evaluation of Critical and / or Subcritical Configuration Data

The benchmark models provided in Section 3.1, for the 56- and 60-fuel-element core configurations were utilized with perturbations of the model parameters to estimate uncertainties in k_{eff} due to uncertainties in parameter values defining the benchmark configuration. Some perturbations required more detail than that available in the benchmark model. More detailed models (Appendix C) were used to evaluate these uncertainties. Transformation from the detailed model to the benchmark model is described in Section 3.1.1.1. Where applicable, comparison of the upper and lower perturbation k_{eff} values to evaluate the uncertainty in the eigenvalue were utilized to minimize correlation effects, if any, induced by comparing all perturbations to the original benchmark model configuration, as discussed elsewhere.^c

An uncertainty analysis of the initial critical measured with the 56-fuel-element core was not evaluated in the original evaluation as the purpose of this experiment was only a step in developing the 60-fuel-element core for reactor operations. This benchmark report was later revised to include an uncertainty analysis of the 56-fuel-element core; only the parameters contributing to the overall uncertainty in the 60-fuel-element core were evaluated for the 56-fuel-element core (see Section 2.1.12.2).

Additional critical configurations were recorded during the start-up measurements; the initial critical configuration for the 56-fuel-element core with additional detectors, a second critical configuration for the 60-fuel-element operational core with the regulating rod fully withdrawn and the shim rods partially inserted, four configurations with one of the graphite reflector blocks removed from the core, and multiple critical positions for both core configurations during the positive period measurements (see Section 1.4). These configurations are considered very similar to the benchmark experiment configurations and therefore were not evaluated as criticality experiments but as worth measurements (see Section 3.4).

Unless specifically stated otherwise, all uncertainty values in this section correspond to 1σ . When the change in k_{eff} between the base case and the perturbed model, or between two perturbed models, is less than the statistical uncertainty of the Monte Carlo results, the changes in the variable are amplified, if possible, and the calculations repeated. The resulting calculated change is then scaled back corresponding to the actual uncertainty, assuming that it is linear, which should be adequate for these changes in k_{eff} .

^a X-5 Monte Carlo Team, "MCNP – a General Monte Carlo n-Particle Transport Code, version 5," LA-UR-03-1987, Los Alamos National Laboratory (2003).

^b M. B. Chadwick, et al., "ENDF/B-VII.0: Next Generation Evaluated Nuclear Data Library for Nuclear Science and Technology," *Nucl. Data Sheets*, **107**: 2931-3060 (2006).

^c D. Mennerdahl, "Statistical Noise for Nuclear Criticality Safety Specialists," *Trans. Am. Nucl. Soc.*, **101**: 465-466 (2009).

Uncertainties ≤ 0.00010 are considered negligible because their calculated worth is within the statistical uncertainty of the Monte Carlo approach being utilized.

The total evaluated uncertainty in k_{eff} for this experiment is provided in Section 2.1.12. The square root of the sum of the squares of all the individual uncertainties assessed in this section is used to obtain the total uncertainty in the experimental k_{eff} .

When evaluating parameters such as part diameters, heights, and mass, all parts of a given type are perturbed at the same time: e.g., the uranium mass in all fuel elements is simultaneously increased or decreased. Then the calculated uncertainty is reduced by the square root of the number of components perturbed, representative of a random uncertainty. For many of these uncertainties, there is insufficient information available to evaluate what portion of the total evaluated uncertainty is systematic instead of random. Random uncertainties are treated as 15% systematic in this evaluation, unless otherwise specified.

This assumption provides a basic prediction of the effect on k_{eff} until additional information regarding systematic uncertainties can be better evaluated. Most systematic uncertainties should be below 50% of the total uncertainty and above the historic approach of ignoring the unknown systematic components (i.e., treat it with a 0% probability). In actuality, careful experimenters may have an unknown systematic uncertainty that is approximately 10-15% of their total reported uncertainty. Because significant effort has gone into obtaining and evaluating data for the NRAD reactor, a systematic uncertainty of 15% is assumed. Evaluated uncertainties are listed as calculated, such that the readers may themselves adjust results according to some desired systematic-to-random uncertainty ratio.

2.1.1 Experimental Measurements

2.1.1.1 Temperature

The thermistor used to directly measure the bulk tank water temperature has a calibrated accuracy of 0.1 °C. A larger uncertainty of 2 °C was assumed to represent a 1σ uncertainty that includes possible uncertainty in bulk water temperature distribution, calibration standard uncertainty, and accuracy of the thermistor measurement. This value is also ten times the typical variability seen in the tank water temperature.

The temperature of the cold critical system directly impacts the density of the tank water and its effectiveness as a neutron moderator and reflector. Because this is a low power experiment, other temperature effects in neutron cross section data and material properties of reactor fuel, assemblies, and core components are assumed to be negligible compared to the effective change in the water density. This section addresses the effect of the temperature uncertainty on the water density while Section 2.1.9 provides further explanation regarding the physical properties of the tank water, including the correlation of water density with temperature.

To find the effect of this uncertainty on the k_{eff} value, the measured temperature was adjusted by the 3σ uncertainty. It should be noted that a perturbation of ± 6 °C does not invoke a linear response in the water density. An upper perturbation k_{eff} value was found by increasing the water density by 0.0014 g/cm³ and then decreasing by 0.0018 g/cm³ to find a lower perturbation k_{eff} value. Half of the difference between the upper and lower perturbation k_{eff} values was used to represent the variation in k_{eff} due to perturbing the measured temperature by 6 °C. The calculated result was then scaled to obtain the 1σ uncertainty. Results are shown in Table 2.1.

This uncertainty is treated as 100% systematic. The calculated uncertainty in the experiment temperature is considered negligible (≤ 0.00010).

Table 2.1. Effect of Uncertainty in Temperature (Water Density).

Deviation	Δk	\pm	$\sigma_{\Delta k}$	Scaling Factor	$\Delta k_{\text{eff}} (1\sigma)$	\pm	$\sigma_{\Delta k_{\text{eff}}}$
$\pm 6 \text{ }^\circ\text{C}$ (+0.0018 g/cm ³) (-0.0014 g/cm ³)	-0.00011	\pm	0.00005	3	-0.00004	\pm	0.00002

2.1.1.2 Control Rod Positions

The uncertainty in the measurement of control rod position is ± 4 units, ± 0.1524 cm, (3σ). The critical control rod positions for the shim 1, shim 2, and regulating rods were reported to be withdrawn 1000, 1000, and 536 units (38.1, 38.1, and 20.4216 cm), respectively. The rod position indication displays 0-1000 units of travel from a down limit switch to the up limit switch, respectively. Each unit of display is equal to 0.015 in. (0.0381 cm) of rod travel.

To find the effect of this uncertainty on the k_{eff} value, the control rod positions were adjusted by a factor of 10 times the 1σ uncertainty. An upper perturbation k_{eff} value was found by simultaneously increasing the rod positions by 0.508 cm and then simultaneously decreasing by the same amount to find a lower perturbation k_{eff} value. Half of the difference between the upper and lower perturbation k_{eff} values was used to represent the variation in k_{eff} due to perturbing the measured control rod positions by 0.508 cm. The calculated result was then scaled to obtain the 1σ uncertainty. Results are shown in Table 2.2.

This uncertainty is treated as 100% systematic for two reasons: first, the uncertainty in the fully inserted and fully withdrawn positions is approximately the same as the uncertainty in the control rod position; second, two of the three control rods are fully withdrawn, and reactivity effects due to the variation in their absolute position are minor compared to those incurred by the movement of the regulating rod. The calculated uncertainty in the control rod positions is considered negligible (≤ 0.00010).

Table 2.2. Effect of Uncertainty in Control Rod Positions.

Deviation	Δk	\pm	$\sigma_{\Delta k}$	Scaling Factor	$\Delta k_{\text{eff}} (1\sigma)$	\pm	$\sigma_{\Delta k_{\text{eff}}}$
± 0.508 cm (10σ)	0.00062	\pm	0.00005	10	0.00006	\pm	0.00001

2.1.1.3 Measured Value of k_{eff}

There is no additional information regarding the accuracy of the k_{eff} measurements for the critical core conditions. Fission counts, linear power, regulating control rod position, and reactor period were all monitored for stability to confirm the critical state of the NRAD reactor. This uncertainty is typically very small and can be considered negligible.

The AmBe source remains in the reactor core during operations. It emits neutrons at the rate of $\sim 1 \times 10^7$ neutrons/sec. The fission rate in the core at 50 W is $\sim 1 \times 10^{12}$ neutrons/sec. Because there are five orders of magnitude difference between the total fission rate and the AmBe source strength, the contribution of the AmBe source neutrons to the total neutron population is judged to be negligible and no additional bias or uncertainty was evaluated.

2.1.2 Fuel Pellet – Uranium-Erbium-Zirconium-Hydride Fuel Properties

The composition of the uranium-erbium-zirconium-hydride fuel is determined using the summary of as-built fuel data for the 60-fuel-element core configuration supplemented with additional information provided by General Atomics, Y-12, or CERCA. The average mass of uranium and ²³⁵U can be

compared to the total average mass of a single fuel element to obtain the weight fraction of uranium and enrichment (see Table 1.5). The average weight fractions of carbon and erbium are also available in Table 1.5.

The only ^{234}U and ^{236}U content measurements available from the Y-12 data are for some of the NRAD fuel elements not currently used in the core (Table 1.7). They are 0.159 and 0.144 wt.%, respectively, using isotopic dilution measurements, and 0.145 and 0.121 wt.%, respectively, calculated from the alpha spectrometry measurement data. Additional data for the ^{232}U , ^{234}U , and ^{236}U content were obtained regarding samples of Y-12 uranium fuel shipments (reported average values from seven measurements: 0.00004 ppm, 0.156 wt.%, and 0.1289 wt.%, respectively) to CERCA during this time period.^a Additional fuel measurements obtained from CERCA represent five uranium batches (Appendix H); the average ^{234}U and ^{236}U content are 0.192 and 0.252 wt.%, respectively.^b

The average fuel content of ^{232}U is negligible and is not included in the fuel composition. The average ^{234}U and ^{236}U weight fractions are computed and ^{238}U represents the remaining uranium content in the fuel. The average ^{234}U and ^{236}U content in the uranium was calculated from the two Y-12 fuel sample measurements and the five CERCA fuel measurements: 0.18 ± 0.02 and 0.22 ± 0.09 wt.%, respectively. The reported average measurements from the Y-12 shipments were not included in this calculation as the details regarding the average and uncertainty were not provided and there is no direct correlation provided between the shipped uranium and the fabricated fuel meat batches.

It is important to note that there is no correlation between the ^{232}U , ^{234}U , and ^{236}U content with fuel enrichment due to various enriching and downblending campaigns at Y-12 over time.^c

Impurities in the fuel are believed to be quite negligible. The results from the Y-12 analysis (Table 1.7) note that it was difficult to overcome interferences with the high quantities of zirconium. Oxygen and nitrogen levels were also not obtainable. Comparison of the zirconium and erbium measurements in Table 1.7 also does not match well with the reported as-built measurements. The ^{235}U , U, and C measurements do agree with the manufacture data. The as-built data for the fuel pellets are within the manufacturing specifications agreed upon between GA and CERCA. The transactinide measurements of the fuel are at the detection limits and the quantities appear to be negligible. The equivalent boron content (EBC) is computed from the five CERCA fuel measurements (Appendix H). The average EBC is 0.96 ± 0.05 ppm. This value is selected to represent the nominal quantity of impurities in the fuel except carbon and hafnium.

Further discussion with General Atomics has indicated that hafnium content of 0.2 wt.% represents more of a limit than the actual composition within the fuel of the NRAD reactor.^d The measured value of Hf in the Y-12 fuel sample was 34 $\mu\text{g/gU}$ (Table 1.7), which is equivalent to ~ 50.2 ppm (wt.%) in zirconium. The Hf content in the zirconium rod was measured (Table 1.12) to be 55 ppm (wt.%). A measurement was provided by CERCA for the zirconium sponge material used in the NRAD reactor (Appendix H) with a Hf content of 46 ppm (wt.%).^e The average Hf content in the zirconium is 50.4 ± 4.5 ppm (wt.%). This is equivalent to a Hf content in the fuel of approximately 34.1 ppm (wt.%).

The remaining fuel mass is the zirconium hydride material. The H/Zr ratio is used to estimate the weight fractions of hydrogen and zirconium in the fuel. The actual quantity is slightly less due to the presence of impurities neglected by assuming hafnium, carbon, and a boron equivalent are the only impurities.

^a Personal communication with Eric C. Woolstenhulme at INL (April 27, 2010).

^b Personal communication with John M. Bolin at General Atomics (April 11, 2011).

^c Personal communication with Calvin M. Hopper at ORNL—retired (April 9, 2010).

^d Personal communication with John M. Bolin at General Atomics (April 7, 2011).

^e Personal communication with John M. Bolin at General Atomics (April 8, 2011).

However, minor variation in the zirconium hydride content is negligible compared to the variations performed when perturbing other components of the fuel matrix.

The mass density of the fuel can be obtained by dividing the total average fuel mass by the average fuel volume. The outer diameter of the fuel is 3.4805 cm, the inner diameter is 0.635 cm, and the total fuel element length is 38.02 cm. The total computed volume of the fuel in a single fuel element is $\sim 349.69 \text{ cm}^3$; the average fuel mass density is 7.1678 g/cm^3 . The average fuel composition is summarized in Table 2.3.

Table 2.3. Average Composition of U-Er-Zr-H Fuel (wt.%).

Isotope/Element	56 Fuel Elements	60 Fuel Elements
B ^(a)	0.000096	0.000096
C	0.3	0.3
Er	0.9	0.9
H + Zr + Hf	68.892467	68.881691
H	1.182010	1.181825
Zr	67.707044	67.696454
Hf	0.003413	0.003412
U	29.907437	29.918213
²³² U/U _{tot}	0.0	0.0
²³⁴ U/U _{tot}	0.18	0.18
²³⁵ U/U _{tot}	19.73	19.74
²³⁶ U/U _{tot}	0.22	0.22
²³⁸ U/U _{tot}	79.87	79.86
Total	100.0	100.0

(a) All impurities, except hafnium and carbon, are treated as equivalent boron content.

2.1.2.1 Total Fuel Element Mass

The average fuel element mass in the 60-fuel-element core (Table 1.5), based on the actual measured values of the individual fuel element masses, is $2506.5 \pm 3.4 \text{ g}$. There is very little information available regarding how the measurements were performed, how accurately they were measured, or what uncertainties were present. As-built mass data appears to be accurate to $\pm 0.01 \text{ g}$, consistent with these data being reported to two decimal places (see Appendix D). While the Y-12 chemical specifications for the uranium fuel wt.% are indicated to two or three decimal places, actual sample measurements of fuel shipped from Y-12 are reported to three or four decimal places. Reprocessed material at CERCA is reported to one or two decimal places (wt.%).^a An uncertainty of $\pm 0.1 \text{ g}$ (1σ) seems reasonable for uncertainty in measurements of the $\sim 2.5 \text{ kg}$ fuel element masses.

To find the effect of the fuel element mass uncertainty on k_{eff} , the average fuel mass was adjusted, while maintaining the fuel element composition and dimensions constant, by a factor of 34 times the 1σ uncertainty. An upper perturbation k_{eff} value was found by simultaneously increasing the average fuel element mass in all fuel elements by 3.4 g and then simultaneously decreasing by the same amount to find a lower perturbation k_{eff} value. Half of the difference between the upper and lower perturbation k_{eff}

^a Personal communication with Eric C. Woolstenhulme at INL (April 27, 2010).

values was used to represent the variation in k_{eff} due to perturbing the average fuel mass by 3.4 g. The calculated result was then scaled to obtain the 1σ uncertainty (i.e. the uncertainty in k_{eff} corresponding to a ± 0.1 g fuel mass). Results are shown in Table 2.4.

The calculated uncertainty in the total fuel mass is considered negligible (≤ 0.00010). The total number of fuel elements in this configuration is 60; the random component of this uncertainty would typically be divided by $\sqrt{60}$; however, division into systematic and random components is irrelevant.

Table 2.4. Effect of Uncertainty in Total Fuel Mass.

Deviation	Δk	\pm	$\sigma_{\Delta k}$	Scaling Factor	$\Delta k_{\text{eff}} (1\sigma)$	\pm	$\sigma_{\Delta k_{\text{eff}}}$	Δk_{eff} (15% systematic)	Δk_{eff} (85% random)
± 3.4 g	0.00031	\pm	0.00005	34	0.00001	\pm	negligible	negligible	negligible

2.1.2.2 Uranium Content

The average uranium mass of the fuel elements in the 60-fuel-element core (Table 1.5) is 749.9 ± 2.7 g, based on the reported measured values of the uranium mass of the individual fuel elements (Appendix D). This results in an average uranium mass content of approximately 29.92 ± 0.11 wt.%. As noted previously, there is very little information available regarding how the measurements were performed, how accurately they were measured, or what uncertainties were present. And as above, an uncertainty of ± 0.1 g (1σ) seems reasonable for the uncertainty in measurements of 1-2 kg uranium masses in the blending of the uranium alloy.

To find the effect of this uncertainty on the k_{eff} value, the average uranium mass was adjusted by a factor of 27 times the 1σ uncertainty. An upper perturbation k_{eff} value was found by simultaneously increasing the average uranium mass in all fuel elements by 2.7 g and then simultaneously decreasing by the same amount to find a lower perturbation k_{eff} value. Half of the difference between the upper and lower perturbation k_{eff} values was used to represent the variation in k_{eff} due to perturbing the average uranium mass by 2.7 g. The calculated result was then scaled to obtain the 1σ uncertainty. Results are shown in Table 2.5.

Increasing or decreasing the total mass of uranium in the fuel effectively decreases or increases the total mass of zirconium hydride in the fuel, changing the U/Zr-H ratio. The ^{235}U enrichment (19.74 wt.%) is conserved when perturbing the total uranium mass, which means the $^{235}\text{U}/^{238}\text{U}$ ratio remains unchanged with the perturbation of the total uranium mass. The calculated uncertainty in the total uranium mass is considered negligible (≤ 0.00010). The total number of fuel elements in this configuration is 60; the random component of this uncertainty would typically be divided by $\sqrt{60}$; however, division into systematic and random components is irrelevant.

Table 2.5. Effect of Uncertainty in Uranium Mass.

Deviation	Δk	\pm	$\sigma_{\Delta k}$	Scaling Factor	$\Delta k_{\text{eff}} (1\sigma)$	\pm	$\sigma_{\Delta k_{\text{eff}}}$	Δk_{eff} (15% systematic)	Δk_{eff} (85% random)
± 2.7 g	0.00028	\pm	0.00005	27	0.00001	\pm	negligible	negligible	negligible

2.1.2.3 Uranium Isotopic Distribution

The average isotopic abundance of ^{235}U for the fuel elements in the 60-fuel-element core (Table 1.5) is 19.74 ± 0.02 wt.%, based on reported as-built values for the individual fuel elements (Appendix D). As noted previously, there is very little information available regarding how the measurements were performed, how accurately they were measured, or what uncertainties were present. Fuel specifications from Y-12 indicate an uncertainty of ± 0.20 wt.% (Table 1.6), which appears to represent bounding values for fuel acceptance. The variation in the reported enrichments is much smaller. The entire range of the reported ^{235}U enrichments is 0.07 wt.%. Treating the quoted specification of ± 0.20 wt.% as a tolerance for acceptance, a reasonable estimate of the 1σ uncertainty is $0.20 \text{ wt.}\% \div 2\sqrt{3}$, or ~ 0.06 wt.%. This uncertainty in the ^{235}U enrichment is equivalent to $\pm 0.43 \text{ g } ^{235}\text{U}$.

Typical calibration standards for the evaluation of isotopic measurements of nominally 20% enriched uranium fuel had an uncertainty in ^{235}U content of approximately ± 0.020 wt.% (2σ),^a which is a 1σ uncertainty of $\pm 0.11 \text{ g}$. This uncertainty is approximately 25% of the uncertainty in the ^{235}U isotopic content of the fuel elements, and it is used to represent the systematic component of this uncertainty.

To find the effect of the uncertainty of the ^{235}U enrichment on the k_{eff} value, the average ^{235}U mass was adjusted by a factor of (1.8/0.43) times the 1σ uncertainty of $\pm 0.43 \text{ g}$. An upper perturbation k_{eff} value was found by simultaneously increasing the average ^{235}U mass in all fuel elements by 1.8 g and then simultaneously decreasing by the same amount to find a lower perturbation k_{eff} value. Half of the difference between the upper and lower perturbation k_{eff} values was used to represent the variation in k_{eff} due to perturbing the average ^{235}U mass by 1.8 g. The calculated result was then scaled to obtain the 1σ uncertainty. Results are shown in Table 2.6.

Increasing or decreasing the total mass of ^{235}U in the fuel effectively decreases or increases the total mass of ^{238}U , changing the enrichment, as the total uranium mass is conserved. The isotopic quantities of the other uranium isotopes remain unchanged. Details of the enrichment batches were not provided for each of the individual fuel elements; it was reported that a total of eleven fuel batches of uranium metal were shipped from Y-12 to CERCA for use in the fabrication of the NRAD fuel elements. It appears that the fuel elements were fabricated from 11 or fewer (most likely 11) enrichment batches; therefore the random component of this uncertainty is divided by $\sqrt{11}$.

Table 2.6. Effect of Uncertainty in Uranium-235 Mass.

Deviation	Δk	\pm	$\sigma_{\Delta k}$	Scaling Factor	Δk_{eff} (1σ)	\pm	$\sigma_{\Delta k_{\text{eff}}}$	Δk_{eff} (25% systematic)	Δk_{eff} (75% random)
$\pm 1.8 \text{ g}$ (± 0.24 wt.%)	0.00228	\pm	0.00003	(1.8/0.43)	0.00054	\pm	0.00001	0.00014	0.00012

As discussed in Section 2.1.2, the quantity of ^{232}U in the fuel is negligible. Any uncertainty in the content would also have a negligible effect on k_{eff} . The ^{234}U and ^{236}U contents were not typically measured except in some select fuel samples, some of which may not represent uranium used in the NRAD fuel. However, all samples discussed in Section 2.1.2 are from uranium material originating from Y-12. Approximate averages and 1σ uncertainties are estimated from these fuel samples because of the ambiguity regarding actual content of these isotopes in the fuel.

^a National Bureau of Standards Certificate of Analysis Standard Reference Material U-200 (SRM-U200), U.S. Department of Commerce (April 6, 1981).

The average ^{234}U content in the fuel, based on the discussion of available data in Section 2.1.2, is 0.18 ± 0.02 wt.% (1σ). This is the average of seven measurements: two from the extra fuel element and five from CERCA measurements.

To find the effect of this uncertainty on the k_{eff} value, a ^{234}U content of 0.18 wt.% was adjusted by a factor of 3 times the 1σ uncertainty. An upper perturbation k_{eff} value was found by simultaneously increasing the ^{234}U content in all fuel elements by 0.06 wt.% and then simultaneously decreasing by the same amount to find a lower perturbation k_{eff} value. Half of the difference between the upper and lower perturbation k_{eff} values was used to represent the variation in k_{eff} due to perturbing the ^{234}U content by 0.02 wt.%. The calculated result was then scaled to obtain the 1σ uncertainty. Results are shown in Table 2.7.

Table 2.7. Effect of Uncertainty in Uranium-234 Content.

Deviation	Δk	\pm	$\sigma_{\Delta k}$	Scaling Factor	$\Delta k_{\text{eff}} (1\sigma)$	\pm	$\sigma_{\Delta k_{\text{eff}}}$
± 0.06 wt.% (± 0.45 g)	-0.00094	\pm	0.00005	3	-0.00031	\pm	0.00002

The average ^{236}U content is 0.22 ± 0.09 wt.% (1σ). This is the average of seven measurements: two from the extra fuel element and five from CERCA measurements.

To find the effect of this uncertainty on the k_{eff} value, a ^{236}U content of 0.22 wt.% was adjusted by a factor of 2 times the 1σ uncertainty. An upper perturbation k_{eff} value was found by simultaneously increasing the ^{236}U content in all fuel elements by 0.18 wt.% and then simultaneously decreasing by the same amount to find a lower perturbation k_{eff} value. Half of the difference between the upper and lower perturbation k_{eff} values was used to represent the variation in k_{eff} due to perturbing the ^{236}U content by 0.09 wt.%. Results are shown in Table 2.8.

Table 2.8. Effect of Uncertainty in Uranium-236 Content.

Deviation	Δk	\pm	$\sigma_{\Delta k}$	Scaling Factor	$\Delta k_{\text{eff}} (1\sigma)$	\pm	$\sigma_{\Delta k_{\text{eff}}}$
± 0.18 wt.% (± 1.35 g)	-0.00092	\pm	0.00005	2	-0.00046	\pm	0.00002

The uncertainty in the ^{234}U and ^{236}U contents is treated as 100% systematic because the isotopic content of ^{234}U and ^{236}U is not recorded for any of the fuel elements in the NRAD core. Increasing or decreasing the total mass of ^{232}U , ^{234}U , or ^{236}U in the fuel effectively decreases or increases the total mass of ^{238}U . The ^{235}U mass and enrichment remains unchanged. Total uranium mass and total fuel mass are conserved.

2.1.2.4 Fuel Element Dimensions

The average fuel element length and outer diameter in the 60-fuel-element core (Table 1.5) are 38.02 ± 0.04 cm (1σ) and 3.4805 ± 0.0003 cm (1σ), respectively. The inner diameter of the fuel is 0.635 cm, with manufacturing tolerance limits of +0.00 and -0.0254 cm.

To find the effect of this uncertainty on the k_{eff} value, the fuel dimensions were individually adjusted by their respective uncertainties. An upper perturbation k_{eff} value was found by simultaneously increasing the average dimension (length, inner diameter, or outer diameter) in all fuel elements and then simultaneously decreasing by the same amount to find a lower perturbation k_{eff} value. Half of the difference between the upper and lower perturbation k_{eff} values was used to represent the variation in k_{eff} due to perturbing the fuel dimensions. The calculated results were then scaled to obtain their 1σ

uncertainty. Results are shown in Tables 2.9, 2.10, and 2.11 for fuel element length, inner diameter, and outer diameter, respectively.

The total mass of the fuel elements is conserved when making adjustments to the fuel dimensions. Because the zirconium rod in the center of the fuel element represents part of the fuel element structure, changes in the length of the fuel element also affect the length of the zirconium rod. The zirconium rod dimensions remain unchanged when the inner and outer diameters of the fuel element are varied. The total number of fuel elements in this configuration is 60; therefore the random component of this uncertainty is divided by $\sqrt{60}$. The calculated uncertainty in all fuel element dimensions is considered negligible (≤ 0.00010).

Table 2.9. Effect of Uncertainty in Fuel Length.

Deviation	Δk	\pm	$\sigma_{\Delta k}$	Scaling Factor	$\Delta k_{\text{eff}} (1\sigma)$	\pm	$\sigma_{\Delta k_{\text{eff}}}$	Δk_{eff} (15% systematic)	Δk_{eff} (85% random)
± 0.12 cm	-0.00035	\pm	0.00005	3	-0.00012	\pm	0.00002	-0.00002	-0.00001

Table 2.10. Effect of Uncertainty in Fuel Inner Diameter.

Deviation	Δk	\pm	$\sigma_{\Delta k}$	Scaling Factor	$\Delta k_{\text{eff}} (1\sigma)$	\pm	$\sigma_{\Delta k_{\text{eff}}}$	Δk_{eff} (15% systematic)	Δk_{eff} (85% random)
-0.0254 cm	-0.00027	\pm	0.00010	$\sqrt{3}$	-0.00016	\pm	0.00006	0.00002	0.00002

Table 2.11. Effect of Uncertainty in Fuel Outer Diameter.

Deviation	Δk	\pm	$\sigma_{\Delta k}$	Scaling Factor	$\Delta k_{\text{eff}} (1\sigma)$	\pm	$\sigma_{\Delta k_{\text{eff}}}$	Δk_{eff} (15% systematic)	Δk_{eff} (85% random)
± 0.0009 cm	-0.00003	\pm	0.00005	3	-0.00001	\pm	0.00002	negligible	negligible

2.1.2.5 Hydride Ratio

The average fuel H/Zr ratio in the 60-fuel-element core (Table 1.5) is 1.58 ± 0.01 (1σ).

To find the effect of this uncertainty on the k_{eff} value, the average fuel hydride ratio was adjusted by the 3σ uncertainty. An upper perturbation k_{eff} value was found by simultaneously increasing the hydride ratio in all fuel elements by 0.03 and then simultaneously decreasing by the same amount to find a lower perturbation k_{eff} value. Half of the difference between the upper and lower perturbation k_{eff} values was used to represent the variation in k_{eff} due to perturbing the average fuel hydride ratio by 0.03. The calculated result was then scaled to obtain the 1σ uncertainty. Results are shown in Table 2.12.

Increasing or decreasing the hydride ratio does not affect the mass of any other fuel constituents. The total number of fuel elements in this configuration is 60; therefore the random component of this uncertainty is divided by $\sqrt{60}$.

Table 2.12. Effect of Uncertainty in Hydride Ratio.

Deviation	Δk	\pm	$\sigma_{\Delta k}$	Scaling Factor	$\Delta k_{\text{eff}} (1\sigma)$	\pm	$\sigma_{\Delta k_{\text{eff}}}$	Δk_{eff} (15% systematic)	Δk_{eff} (85% random)
$\pm 0.03 \text{ H:Zr}$	0.00295	\pm	0.00005	3	0.00098	\pm	0.00002	0.00015	0.00011

2.1.2.6 Hydride Homogeneity

It is unknown how homogeneously throughout the fuel the hydrogen is distributed during the hydriding process. Diffusion of hydrogen in hollow cylinders of zirconium alloy exhibits a fairly flat concentration profile. However, there are slight nonlinear effects due to thermal stresses, such as can be incurred due to impurities in the metal alloy.^a Micrographs of fuel samples from the extra fuel element are in Appendix G. Neither carbon nor uranium has any effect on the hydrogen diffusion process for H/Zr ratios between 1.5 and 1.8. Erbium and uranium can be uniformly melted into a zirconium alloy; there is no reason to believe that erbium would segregate, as it forms a stable hydride and stays uniformly dispersed.^b There is some indication that the distribution of hydrogen has on average a constant profile throughout a sample of hydride discs being used in thermal migration studies of hydrogen in zirconium-uranium-hydrogen alloys. Two discs nominally containing $\text{ZrH}_{1.6}\text{U}_{0.03}$ exhibited hydrogen-to-zirconium ratios of approximately 1.65, bound between 1.60 and 1.70. Another sample of just $\text{ZrH}_{1.6}$ was sampled five times with the following ratios: 1.68, 1.72, 1.69, 1.69, and 1.65.^c The average ratio for the $\text{ZrH}_{1.6}$ sample is $1.69 \pm 0.03 (1\sigma)$. If the bounding limits for the $\text{ZrH}_{1.6}\text{U}_{0.03}$ samples are converted to 1σ by dividing the limit by $\sqrt{3}$, the average ratio is $\sim 1.65 \pm 0.03 (1\sigma)$. It is concluded that the as-built distribution of hydride throughout the fuel matrix is not completely homogenous and has a 1σ uncertainty approximately three times greater than the variation in average ratios between the individual fuel elements. It is unclear how the H/Zr ratio is measured for the fuel; therefore, this uncertainty is treated as an additional uncertainty in the hydride composition of the fuel.

Three methods were utilized to evaluate the uncertainty in the homogeneity of the hydride in the fuel. The first two analysis methods overestimate the actual uncertainty. They are retained in this document as the pathway towards analysis of this uncertainty.

Method 1:

This first method follows the same analysis procedure as described in Section 2.1.2.6, but with a larger uncertainty.

To find the effect of this uncertainty on the k_{eff} value, the average fuel hydride ratio was adjusted by the 1σ uncertainty. An upper perturbation k_{eff} value was found by simultaneously increasing the hydride ratio in all fuel elements by 0.03 and then simultaneously decreasing by the same amount to find a lower perturbation k_{eff} value. Half of the difference between the upper and lower perturbation k_{eff} values was used to represent the variation in k_{eff} due to perturbing the average fuel hydride ratio by 0.03. Results are shown in Table 2.13.

^a N. M. Vlasov and V. A. Zaznoba, "Thermal Diffusion of Hydrogen in Zirconium with Allowance for Thermal Stresses," *Tech. Phys.*, **54**, 651-655 (2009).

^b M. T. Simnad, "The U-ZrH_x Alloy: Its Properties and Use in TRIGA Fuel," E-117-833, GA Project No. 4314, General Atomics (February 1980). [This reference is not available for public release.]

^c U. Merten, J. C. Bokros, D. G. Guggisberg, and A. P. Hatcher, "Thermal Migration of Hydrogen in Zirconium-Uranium-Hydrogen Alloys," *J. Nucl. Mater.*, **10**, 201-208 (1963).

Increasing or decreasing the hydride ratio does not affect the mass of any other fuel constituents. The total number of fuel elements in this configuration is 60; therefore the random component of this uncertainty is divided by $\sqrt{60}$.

This method significantly overestimated the actual uncertainty in hydride homogeneity as it assumed the entire fuel meat was perturbed instead of random variation in localized ratios.

Method 2:

The approach of the second method was to divide the fuel meat radially into thirds (by volume). The average hydrogen-to-zirconium ratio of 1.58 ± 0.03 was preserved but the volumetric ratios were different. The center third of the fuel had a ratio of 1.61 while the other two thirds had a ratio of 1.565. The k_{eff} value was then calculated assuming all fuel rods have this distribution.

To find the effect of this uncertainty on the k_{eff} value, the perturbed k_{eff} value was compared to the unperturbed k_{eff} value; the difference between the two k_{eff} values was used to represent the variation in k_{eff} due to perturbing the average fuel hydride ratio by 0.03. Results are shown in Table 2.13.

Increasing or decreasing the hydride ratio does not affect the mass of any other fuel constituents. The total number of fuel elements in this configuration is 60; therefore the random component of this uncertainty is divided by $\sqrt{60}$.

This method also overestimated the actual uncertainty in hydride homogeneity as it assumed the entire fuel meat was perturbed in large sections instead of by random variation in localized ratios. However, the effective uncertainty in this parameter appears to be negligible.

Method 3:

A final method was developed to confirm whether this uncertainty, as it appears in the analysis of Method 2, is negligible. A cube with dimensions of 0.06 cm on all sides was divided into 27 smaller cubes containing fuel material. Each cube contained fuel material that was identical except for the hydrogen-to-zirconium ratio. The average ratio of 1.58 ± 0.03 was preserved across the cube. The fuel in the model was divided into cubic grids with dimensions of 0.02 cm on all sides. This lattice is larger than the microlattice structure of the actual fuel material (Appendix G); a smaller lattice using this method, however, would have required a significant quantity of computing time that was deemed unnecessary to further refine this uncertainty analysis. The URAN card in MCNP5^a was used to randomly pick material from the larger “cube” of materials to place within the smaller cubic lattice. The average hydrogen-to-zirconium ratio was preserved throughout the calculations.

To find the effect of this uncertainty on the k_{eff} value, the perturbed k_{eff} value was compared to the unperturbed k_{eff} value; the difference between the two k_{eff} values was used to represent the variation in k_{eff} due to perturbing the average fuel hydride ratio by 0.03. Results are shown in Table 2.13.

Increasing or decreasing the hydride ratio does not affect the mass of any other fuel constituents. The total number of fuel elements in this configuration is 60; therefore the random component of this uncertainty is divided by $\sqrt{60}$.

The calculated uncertainty in hydrogen homogeneity is considered negligible (≤ 0.00010).

^a X-5 Monte Carlo Team, “MCNP – A General Monte Carlo N-Particle Transport Code, Version 5, Volume II: User’s Guide,” LA-CP-03-0245, Los Alamos National Laboratory (October 3, 2005).

Table 2.13. Effect of Uncertainty in Hydride Homogeneity.

Method	Deviation	Δk	\pm	$\sigma_{\Delta k}$	Scaling Factor	Δk_{eff} (1 σ)	\pm	$\sigma_{\Delta k_{\text{eff}}}$	Δk_{eff} (15% systematic)	Δk_{eff} (85% random)
1	±0.03 H:Zr	0.00295	±	0.00005	1	0.00295	±	0.00005	0.00044	0.00032
2		0.00024	±	0.00010	1	0.00024	±	0.00010	0.00003	0.00010
3		0.00003	±	0.00010	1	0.00003	±	0.00010	negligible	0.00001

2.1.2.7 Erbium Content

The average fuel erbium content in the 60-fuel-element core (Table 1.5) is 0.90 ± 0.02 wt.% (1 σ).

To find the effect of this uncertainty on the k_{eff} value, the average fuel erbium content was adjusted by the 3 σ uncertainty. An upper perturbation k_{eff} value was found by simultaneously increasing the average erbium content in all fuel elements by 0.06 wt.% and then simultaneously decreasing by the same amount to find a lower perturbation k_{eff} value. Half of the difference between the upper and lower perturbation k_{eff} values was used to represent the variation in k_{eff} due to perturbing the average fuel erbium content by 0.06 wt.%. The calculated result was then scaled to obtain the 1 σ uncertainty. Results are shown in Table 2.14.

Increasing or decreasing the total erbium content in the fuel effectively decreases or increases the total mass of zirconium hydride in the fuel, changing the U/Zr-H ratio. The total number of fuel elements in this configuration is 60; therefore the random component of this uncertainty is divided by $\sqrt{60}$.

Table 2.14. Effect of Uncertainty in Erbium Content.

Deviation	Δk	\pm	$\sigma_{\Delta k}$	Scaling Factor	Δk_{eff} (1 σ)	\pm	$\sigma_{\Delta k_{\text{eff}}}$	Δk_{eff} (15% systematic)	Δk_{eff} (85% random)
±0.06 wt.%	-0.00797	±	0.00005	3	-0.00266	±	0.00002	-0.00040	-0.00029

2.1.2.8 Carbon Content

The average fuel carbon content in the 60-fuel-element core (Table 1.5) is 0.30 ± 0.02 wt.% (1 σ).

To find the effect of this uncertainty on the k_{eff} value, the average fuel carbon content was adjusted by the 3 σ uncertainty. An upper perturbation k_{eff} value was found by simultaneously increasing the average carbon content in all fuel elements by 0.06 wt.% and then simultaneously decreasing by the same amount to find a lower perturbation k_{eff} value. Half of the difference between the upper and lower perturbation k_{eff} values was used to represent the variation in k_{eff} due to perturbing the average fuel carbon content by 0.06 wt.%. The calculated result was then scaled to obtain the 1 σ uncertainty. Results are shown in Table 2.15.

Increasing or decreasing the total carbon content in the fuel effectively decreases or increases the total mass of zirconium hydride in the fuel, changing the U/Zr-H ratio. The total number of fuel elements in this configuration is 60; therefore the random component of this uncertainty is divided by $\sqrt{60}$. The calculated uncertainty in the average fuel carbon content is considered negligible (≤ 0.00010).

Table 2.15. Effect of Uncertainty in Carbon Content.

Deviation	Δk	\pm	$\sigma_{\Delta k}$	Scaling Factor	$\Delta k_{\text{eff}} (1\sigma)$	\pm	$\sigma_{\Delta k_{\text{eff}}}$	Δk_{eff} (15% systematic)	Δk_{eff} (85% random)
± 0.06 wt.%	-0.00003	\pm	0.00005	3	-0.00001	\pm	0.00002	negligible	negligible

2.1.2.9 Additional Impurity Content

The average Hf content in the zirconium of the fuel, based on the discussion of available data in Section 2.1.2, is 50.4 ± 4.5 ppm (wt.%, 1σ). This is the average of three measurements: one from the extra fuel element, one from the extra zirconium rod and one from a CERCA measurement of the zirconium sponge material used to manufacture the fuel and rod.

To find the effect of this uncertainty on the k_{eff} value, the hafnium content of 50.4 ppm (wt.%) was adjusted by a factor of 3 times the 1σ uncertainty. An upper perturbation k_{eff} value was found by simultaneously increasing the hafnium content in all fuel elements by 13.5 ppm (wt.%) and then simultaneously decreasing by the same amount to find a lower perturbation k_{eff} value. Half of the difference between the upper and lower perturbation k_{eff} values was used to represent the variation in k_{eff} due to perturbing the hafnium content by 4.5 ppm (wt.%). The calculated result was then scaled to obtain the 1σ uncertainty. Results are shown in Table 2.16.

The average EBC in the fuel, based on the discussion of available data in Section 2.1.2, is 0.96 ± 0.05 ppm (wt.%, 1σ). This is the average of five CERCA measurements.

To find the effect of this uncertainty on the k_{eff} value, the EBC was adjusted by a factor of 3 times the 1σ uncertainty. An upper perturbation k_{eff} value was found by simultaneously increasing the EBC in all fuel elements by 0.15 ppm and then simultaneously decreasing by the same amount to find a lower perturbation k_{eff} value. Half of the difference between the upper and lower perturbation k_{eff} values was used to represent the variation in k_{eff} due to perturbing the EBC by 0.05 ppm. The calculated result was then scaled to obtain the 1σ uncertainty. Results are shown in Table 2.17.

Table 2.16. Effect of Uncertainty in Hafnium Content.

Deviation	Δk	\pm	$\sigma_{\Delta k}$	Scaling Factor	$\Delta k_{\text{eff}} (1\sigma)$	\pm	$\sigma_{\Delta k_{\text{eff}}}$
± 13.5 ppm (wt.%)	-0.00017	\pm	0.00005	3	-0.00006	\pm	0.00002

Table 2.17. Effect of Uncertainty in Equivalent Boron Content.

Deviation	Δk	\pm	$\sigma_{\Delta k}$	Scaling Factor	$\Delta k_{\text{eff}} (1\sigma)$	\pm	$\sigma_{\Delta k_{\text{eff}}}$
± 0.15 ppm (wt.%)	0.00001	\pm	0.00005	3	negligible	\pm	0.00002

This uncertainty in the Hf content and EBC is treated as 100% systematic because the actual impurity content is not recorded for any of the fuel elements in the NRAD core. Increasing or decreasing the impurity content in the fuel effectively decreases or increases the total mass of zirconium hydride in the fuel, changing the U/Zr-H ratio. The calculated uncertainty in the Hf content and EBC is considered negligible (≤ 0.00010).

2.1.3 Fuel Element – Non-Fuel Properties**2.1.3.1 Zirconium Rod****Composition**

The composition of the zirconium rods (Table 2.18) is obtained by reducing the quantity of zirconium to account for the impurities reported in Table 1.12. For elements that are listed only as detection limits, half of the detection limit is assumed to represent the quantity of that impurity in the zirconium material.

Table 2.18. Composition of Zirconium.

Element	wt.%	Element	wt.%	Element	wt.%
Li	0.00000025	As	0.000004	Sm	0.00000025
Be	0.00000025	Se	0.0000025	Eu	0.00000025
B	0.000005	Br	0.0000025	Gd	0.00000025
F	0.00005	Rb	0.0000025	Tb	0.00000025
Na	0.0000005	Sr	0.0000025	Dy	0.00000025
Mg	0.00000025	Y	0.0000025	Ho	0.00000025
Al	0.004	Zr	99.8169797	Er	0.00000025
Si	0.00071	Nb	0.000061	Tm	0.00000025
P	0.000079	Mo	0.00022	Yb	0.00000025
S	0.000025	Ru	0.0000025	Lu	0.00000025
Cl	0.000023	Rh	0.0000025	Hf	0.0055
K	0.000005	Pd	0.000025	Ta	0.00025
Ca	0.0000025	Ag	0.000025	W	0.000012
Sc	0.00025	Cd	0.000025	Re	0.00000025
Ti	0.00017	In	0.000005	Os	0.00000025
V	0.000043	Sn	0.000049	Ir	0.00000025
Cr	0.012	Sb	0.0000025	Pt	0.00000025
Mn	0.00014	Te	0.0000025	Au	0.0000025
Fe	0.15	I	0.000005	Hg	0.0000025
Co	0.00011	Cs	0.00000025	Tl	0.0000005
Ni	0.0063	Ba	0.00000025	Pb	0.000036
Cu	0.0013	La	0.00000025	Bi	0.000016
Zn	0.000041	Ce	0.00000025	Th	0.00000005
Ga	0.00022	Pr	0.00000025	U	0.000007
Ge	0.0000025	Nd	0.00000025		

Density

The density of the zirconium rods is not specified. Open literature sources report a density of both 6.506 g/cm³ (*Chart of the Nuclides*)^a and 6.52 g/cm³ (*CRC Handbook of Chemistry and Physics*).^b A density of 6.51 ± 0.01 g/cm³ (1σ) was selected.

To find the effect of this uncertainty on the k_{eff} value, the zirconium density was adjusted by the 3σ uncertainty. An upper perturbation k_{eff} value was found by simultaneously increasing the zirconium density by 0.03 g/cm³ and then simultaneously decreasing by the same amount to find a lower perturbation k_{eff} value. Half of the difference between the upper and lower perturbation k_{eff} values was used to represent the variation in k_{eff} due to perturbing the zirconium density by 0.03 g/cm³. The calculated result was then scaled to obtain the 1σ uncertainty. Results are shown in Table 2.19.

This uncertainty is treated as 100% systematic. The calculated uncertainty in the zirconium rod density is considered negligible (≤0.00010).

Table 2.19. Effect of Uncertainty in Zirconium Density.

Deviation	Δk	±	$\sigma_{\Delta k}$	Scaling Factor	$\Delta k_{\text{eff}} (1\sigma)$	±	$\sigma_{\Delta k_{\text{eff}}}$
±0.03 g/cm ³	0.00006	±	0.00005	3	0.00002	±	0.00002

Dimensions

The length of the zirconium rod is nominally equal to the average fuel element length (Table 1.5), which is 38.02 ± 0.04 cm (1σ). The outer diameter of the zirconium rod (Figure 1.26) is 0.5715 cm with manufacturing tolerance limits of +0.00 and -0.0254 cm.

Perturbations of the zirconium rod length were performed in conjunction with the assessment of the uncertainty in fuel element length and inner diameter. To find the effect of the uncertainty on the k_{eff} value due to the zirconium rod outer diameter, the zirconium rod diameter was adjusted by the 3σ uncertainty. A lower perturbation k_{eff} value was found by simultaneously decreasing the zirconium rod diameter in all fuel elements by 0.0762. The difference between the unperturbed and lower perturbation k_{eff} values was used to represent the variation in k_{eff} due to perturbing the zirconium rod diameter by 0.0762 cm. The calculated result was then scaled to obtain the 1σ uncertainty. Results are shown in Table 2.20.

The total number of fuel elements in this configuration is 60; therefore the random component of this uncertainty is divided by $\sqrt{60}$. The calculated uncertainty in the zirconium dimensions is considered negligible (≤0.00010).

^a E. M. Baum, H. D. Knox, and T. R. Miller, *Nuclides and Isotopes: 16th Edition*, Knolls Atomic Power Laboratory (2002).

^b D. R. Lide, ed., *CRC Handbook of Chemistry and Physics, 90th Edition (Internet Version 2010)*, CRC Press/Taylor and Francis, Boca Raton, FL (2010).

Table 2.20. Effect of Uncertainty in Zirconium Rod Outer Diameter.

Deviation	Δk	\pm	$\sigma_{\Delta k}$	Scaling Factor	$\Delta k_{\text{eff}} (1\sigma)$	\pm	$\sigma_{\Delta k_{\text{eff}}}$	Δk_{eff} (15% systematic)	Δk_{eff} (85% random)
-0.0254 cm	-0.00042	\pm	0.00010	$3\sqrt{3}$	-0.00008	\pm	0.00002	0.00001	0.00001

Impurities

The effective bias for removing impurities (Table 2.18) from the zirconium rod was determined to be negligible (Section 3.1.1.1). Therefore, an uncertainty analysis regarding impurities in the zirconium was judged to be unnecessary as the result would also be negligible.

2.1.3.2 Molybdenum Poison Disc

Composition

The composition of the molybdenum poison discs (Table 2.21) is obtained by reducing the quantity of molybdenum to account for the impurities reported in Tables 1.9 and 1.10. The average impurity content from these two tables is used to represent the quantity of materials in the entire molybdenum disc as no information is available regarding the amount of molybdenum carbide material coating present. Additionally, the total carbon content of the molybdenum is assumed to be 0.01 wt.%. For elements that are listed only as detection limits, half of the detection limit is assumed to represent the quantity of that impurity in the molybdenum material.

Table 2.21. Composition of Molybdenum.

Element	wt.%	Element	wt.%	Element	wt.%
Li	0.0000005	Ge	0.000005	Nd	0.0000005
Be	0.0000005	As	0.000035	Sm	0.0000005
B	0.0000005	Se	0.000005	Eu	0.0000005
C	0.01	Br	0.0000005	Gd	0.0000005
F	0.0000005	Rb	0.0000025	Tb	0.0000005
Na	0.0002885	Sr	0.000025	Dy	0.0000005
Mg	0.000037	Y	0.000005	Ho	0.0000005
Al	0.000044	Zr	0.000005	Er	0.0000005
Si	0.0002	Nb	0.000025	Tm	0.0000005
P	0.000051	Mo	99.968464	Yb	0.0000005
S	0.0001945	Ru	0.0000025	Lu	0.0000005
Cl	0.000001	Rh	0.0000025	Hf	0.0000005
K	0.0025	Pd	0.000005	Ta	0.0005
Ca	0.00018	Ag	0.000025	W	0.0125
Sc	0.00000025	Cd	0.0005	Re	0.000013
Ti	0.0005	In	0.0000025	Os	0.0000025
V	0.00011	Sn	0.000019	Ir	0.0000025
Cr	0.00038	Sb	0.00013	Pt	0.0000025
Mn	0.000043	Te	0.0000025	Au	0.0000025
Fe	0.001175	I	0.0000005	Hg	0.0000025
Co	0.000014	Cs	0.0000025	Tl	0.0000025
Ni	0.00012	Ba	0.0015	Pb	0.0000025
Cu	0.00025	La	0.0000945	Bi	0.0000025
Zn	0.0000025	Ce	0.0000025	Th	0.00000025
Ga	0.0000025	Pr	0.0000005	U	0.000004

Density

The density of the molybdenum disc is not specified. Open literature sources report a density of both 10.22 g/cm³ (Chart of the Nuclides)^a and 10.2 g/cm³ (CRC Handbook of Chemistry and Physics).^b A density of 10.22 ± 0.02 g/cm³ (1σ) was selected.

To find the effect of this uncertainty on the k_{eff} value, the molybdenum density was adjusted by the 3σ uncertainty. An upper perturbation k_{eff} value was found by simultaneously increasing the molybdenum density by 0.06 g/cm³ and then simultaneously decreasing by the same amount to find a lower perturbation k_{eff} value. Half of the difference between the upper and lower perturbation k_{eff} values was used to represent the variation in k_{eff} due to perturbing the molybdenum density by 0.06 g/cm³. The calculated result was then scaled to obtain the 1σ uncertainty. Results are shown in Table 2.22.

This uncertainty is treated as 100% systematic. The calculated uncertainty in the molybdenum disc density is considered negligible (≤0.00010).

Table 2.22. Effect of Uncertainty in Molybdenum Density.

Deviation	Δk	±	σ _{Δk}	Scaling Factor	Δk _{eff} (1σ)	±	σ _{Δk_{eff}}
±0.06 g/cm ³	-0.00006	±	0.00005	3	-0.00002	±	0.00002

Dimensions

The molybdenum poison disc (Figure 1.27) thickness and outer diameter are 0.079375 cm (no reported uncertainty) and 3.46964 cm with manufacturing tolerance limits of +0.000 and -0.0127 cm.

To find the effect of this uncertainty on the k_{eff} value, the molybdenum disc dimensions were adjusted by >10σ uncertainty. An upper perturbation k_{eff} value was found by simultaneously doubling the molybdenum disc volume and then simultaneously decreasing by the same amount (i.e. removing it) to find a lower perturbation k_{eff} value. Half of the difference between the upper and lower perturbation k_{eff} values was used to represent the variation in k_{eff} due to perturbing the molybdenum disc dimensions. The calculated result was then scaled to obtain the 1σ uncertainty. Results are shown in Table 2.23.

The total number of fuel elements in this configuration is 60; therefore the random component of this uncertainty is divided by √60. The calculated uncertainty in the molybdenum dimensions is considered negligible (≤0.00010).

Table 2.23. Effect of Uncertainty in Molybdenum Dimensions.

Deviation	Δk	±	σ _{Δk}	Scaling Factor	Δk _{eff} (1σ)	±	σ _{Δk_{eff}}	Δk _{eff} (15% systematic)	Δk _{eff} (85% random)
±100 vol.%	-0.00020	±	0.00005	10	-0.00002	±	0.00001	negligible	negligible

^a E. M. Baum, H. D. Knox, and T. R. Miller, *Nuclides and Isotopes: 16th Edition*, Knolls Atomic Power Laboratory (2002).

^b D. R. Lide, ed., *CRC Handbook of Chemistry and Physics, 90th Edition (Internet Version 2010)*, CRC Press/Taylor and Francis, Boca Raton, FL (2010).

Impurities

The effective bias for removing impurities (Table 2.21) from the molybdenum poison disc was determined to be negligible (Section 3.1.1.1). Therefore, an uncertainty analysis regarding impurities in the molybdenum was judged to be unnecessary as the result would also be negligible.

2.1.3.3 Axial Graphite Reflector**Composition**

The composition of the axial graphite reflectors (Table 2.24) is obtained by reducing the quantity of graphite to account for the impurities reported in Table 1.8. For elements that are listed only as detection limits, half of the detection limit is assumed to represent the quantity of that impurity in the graphite material.

Table 2.24. Composition of Axial Graphite Reflector.

Element	wt.%	Element	wt.%	Element	wt.%
Li	0.0000025	Ge	0.0000025	Nd	0.0000025
Be	0.0000025	As	0.0000025	Sm	0.0000005
B	0.000035	Se	0.0000025	Eu	0.0000005
C	99.994614	Br	0.000005	Gd	0.0000005
F	0.000005	Rb	0.0000025	Tb	0.0000005
Na	0.0000025	Sr	0.0000025	Dy	0.0000005
Mg	0.0000025	Y	0.0000025	Ho	0.0000005
Al	0.0000025	Zr	0.0000025	Er	0.0000005
Si	0.000075	Nb	0.0000025	Tm	0.0000005
P	0.000005	Mo	0.0000025	Yb	0.0000005
S	0.000092	Ru	0.0000025	Lu	0.0000005
Cl	0.000024	Rh	0.0000005	Hf	0.0000005
K	0.00005	Pd	0.0000025	Ta	0.005
Ca	0.0000025	Ag	0.0000025	W	0.0000025
Sc	0.0000005	Cd	0.0000025	Re	0.0000005
Ti	0.0000005	In	0.0000025	Os	0.0000005
V	0.0000005	Sn	0.0000025	Ir	0.0000005
Cr	0.000025	Sb	0.0000025	Pt	0.0000005
Mn	0.0000005	Te	0.0000025	Au	0.000005
Fe	0.0000005	I	0.0000005	Hg	0.000005
Co	0.0000005	Cs	0.0000025	Tl	0.0000025
Ni	0.0000005	Ba	0.0000025	Pb	0.0000025
Cu	0.0000025	La	0.0000025	Bi	0.0000025
Zn	0.0000025	Ce	0.0000025	Th	0.0000025
Ga	0.0000005	Pr	0.0000025	U	0.0000025

Density

The axial graphite reflectors are nuclear grade graphite, either PGX or ECW. The density of these two graphite types is nominally 1.73 or 1.74 g/cm³, respectively.^a General Atomics uses a density of 1.73 g/cm³ to represent the density of the axial graphite reflectors in their TRIGA reactor models.^b A 1 σ uncertainty of ± 0.01 g/cm³ was selected for the density of the axial graphite reflectors.

To find the effect of this uncertainty on the k_{eff} value, the axial graphite reflector density was adjusted by the 3 σ uncertainty. An upper perturbation k_{eff} value was found by simultaneously increasing the graphite density by 0.03 g/cm³ and then simultaneously decreasing by the same amount to find a lower perturbation k_{eff} value. Half of the difference between the upper and lower perturbation k_{eff} values was used to represent the variation in k_{eff} due to perturbing the graphite density by 0.03 g/cm³. The calculated result was then scaled to obtain the 1 σ uncertainty. Results are shown in Table 2.25.

This uncertainty is treated as 100% systematic. The calculated uncertainty in the axial graphite reflector density is considered negligible (≤ 0.00010).

Table 2.25. Effect of Uncertainty in Axial Graphite Reflector Density.

Deviation	Δk	\pm	$\sigma_{\Delta k}$	Scaling Factor	$\Delta k_{\text{eff}} (1\sigma)$	\pm	$\sigma_{\Delta k_{\text{eff}}}$
± 0.03 g/cm ³	0.00026	\pm	0.00005	3	0.00009	\pm	0.00002

Dimensions

The axial graphite reflector (Figure 1.28) length and outer diameter are 8.6868 ± 0.0254 cm (manufacturing tolerance) and 3.27914 cm with manufacturing tolerance limits of +0.00 and -0.0127 cm.

To find the effect of this uncertainty on the k_{eff} value, the axial graphite reflector dimensions were adjusted by three times their respective tolerance limits. An upper perturbation k_{eff} value was found by simultaneously increasing the graphite volume and then simultaneously decreasing by the same amount to find a lower perturbation k_{eff} value. Half of the difference between the upper and lower perturbation k_{eff} values was used to represent the variation in k_{eff} due to perturbing the graphite reflector dimensions. The calculated result was then scaled to obtain the 1 σ uncertainty. Results are shown in Table 2.26.

The axial graphite reflector diameter was increased in this perturbation analysis even though there is no positive manufacturing tolerance for this dimension. The total number of fuel elements in this configuration is 60, each with two axial graphite reflectors; therefore the random component of this uncertainty is divided by $\sqrt{120}$. The calculated uncertainty in the total uranium mass is considered negligible (≤ 0.00010).

Table 2.26. Effect of Uncertainty in Axial Graphite Reflector Dimensions.

Deviation	Δk	\pm	$\sigma_{\Delta k}$	Scaling Factor	$\Delta k_{\text{eff}} (1\sigma)$	\pm	$\sigma_{\Delta k_{\text{eff}}}$	Δk_{eff} (15% systematic)	Δk_{eff} (85% random)
$\pm 3 \times \text{BL}$	0.00006	\pm	0.00005	$3\sqrt{3}$	0.00001	\pm	0.00001	negligible	negligible

^a Personal communication with Victor Leight at GrafTech International (April 5, 2010).

^b Personal communication with John M. Bolin at General Atomics (November 3, 2009).

Impurities

The effective bias for removing impurities (Table 2.24) from the axial graphite reflectors was determined to be negligible (Section 3.1.1.1). Therefore, an uncertainty analysis regarding impurities in the graphite was judged to be unnecessary as the result would also be negligible.

2.1.3.4 Stainless Steel 304 Cladding and End Fittings

Composition

The average stainless steel 304 or 304L composition is shown in Table 2.27. However, a sample of stainless steel material used in the fuel cladding provided additional information regarding impurity content. The composition of the stainless steel cladding (Table 2.28) is obtained by reducing the quantity of iron in the average steel composition (Table 2.27) to account for the impurities reported in Table 1.11. For elements that are listed only as detection limits, half of the detection limit is assumed to represent the quantity of that impurity in the graphite material.

To initially find the effect of the uncertainty in using an average stainless steel composition on the k_{eff} value, the steel composition was adjusted by minimizing or maximizing the iron content by increasing or decreasing the primary alloy constituents within their respective ranges (the impurity content remained unchanged). An upper perturbation k_{eff} value was found by simultaneously maximizing the iron content and then simultaneously minimizing the iron content to find a lower perturbation k_{eff} value. Half of the difference between the upper and lower perturbation k_{eff} values was used to represent the variation in k_{eff} due to perturbing the stainless steel composition. The calculated result was then scaled to obtain the 1σ uncertainty. Results are shown in Table 2.29.

A total of five constituents were perturbed in this analysis: carbon, chromium, iron, manganese, and nickel. Therefore the eigenvalue uncertainty is reduced by the square root of four (N-1). This uncertainty is also treated as a bounding uncertainty with uniform probability distribution. The phosphorus, sulfur, and silicon constituents are included in the impurity analysis later in this section.

This uncertainty was reevaluated by individually perturbing the carbon, chromium, manganese, and nickel constituents between their maximum and minimum value while simultaneously decreasing or increasing, respectively, the iron content in the steel. Results are provided in Table 2.29. Because the uncertainty in the perturbation of the individual constituents is greater than the uncertainty calculated when performing simultaneous perturbations, the individual uncertainties are selected to represent the total uncertainty in the composition of the stainless steel.

Table 2.27 Typical Stainless Steel 304/304L Composition (wt.%).^(a)

Component	SS304	SS304L	Average^(b)
C	0.08 Max	0.03 Max	0.04
Cr	18 – 20	18 – 20	19
Fe	Balance	Balance	69.4225
Mn	2 Max	2 Max	1
Ni	8 – 10.5	8 – 12	10
P	0.045 Max	0.045 Max	0.0225
S	0.03 Max	0.03 Max	0.015
Si	1 Max	1 Max	0.5
Density (g/cm³)	8.00	8.00	8.00

(a) ASM Aerospace Specification Metals, Inc.,
<http://www.aerospacemetals.com/>.

(b) Average based on the maximum range of each component.

Table 2.28. Stainless Steel 304/304L Cladding Composition (wt.%).

Element	wt.%	Element	wt.%	Element	wt.%
Li	0.0000005	Ge	0.002	Nd	0.00000025
Be	0.0000005	As	0.0035	Sm	0.00000025
B	0.00025	Se	0.000005	Eu	0.00000025
C	0.04	Br	0.000005	Gd	0.00000025
F	0.0000005	Rb	0.000025	Tb	0.00000025
Na	0.0000005	Sr	0.00001	Dy	0.00000025
Mg	0.00018	Y	0.0000025	Ho	0.00000025
Al	0.0012	Zr	0.00018	Er	0.00000025
Si	0.4	Nb	0.011	Tm	0.00000025
P	0.026	Mo	0.3	Yb	0.00000025
S	0.0022	Ru	0.000005	Lu	0.00000025
Cl	0.0000025	Rh	0.0000025	Hf	0.0000005
K	0.0000005	Pd	0.0000025	Ta	0.00005
Ca	0.00005	Ag	0.000025	W	0.016
Sc	0.00000025	Cd	0.000005	Re	0.000025
Ti	0.002	In	0.000025	Os	0.000009
V	0.1	Sn	0.0055	Ir	0.000009
Cr	19	Sb	0.00089	Pt	0.000005
Mn	1	Te	0.0000025	Au	0.0000025
Fe	68.70712775	I	0.0000025	Hg	0.000005
Co	0.08	Cs	0.0000005	Tl	0.0000025
Ni	10	Ba	0.0000025	Pb	0.000031
Cu	0.3	La	0.0000005	Bi	0.0000005
Zn	0.00005	Ce	0.00000025	Th	0.00000025
Ga	0.0016	Pr	0.00000025	U	0.00000025

Table 2.29. Effect of Uncertainty in Stainless Steel Composition.

Deviation	Δk	\pm	$\sigma_{\Delta k}$	Scaling Factor	$\Delta k_{\text{eff}} (1\sigma)$	\pm	$\sigma_{\Delta k_{\text{eff}}}$
Simultaneous Perturbation of C, Cr, Mn, and Ni	-0.00159	\pm	0.00005	$\sqrt{4}\sqrt{3}$	-0.00041	\pm	0.00001
Max/Min Carbon Content	-0.00005	\pm	0.00005	$\sqrt{3}$	-0.00003	\pm	0.00003
Max/Min Chromium Content	0.00000	\pm	0.00005	$\sqrt{3}$	negligible	\pm	0.00003
Max/Min Manganese Content	-0.00114	\pm	0.00005	$\sqrt{3}$	-0.00066	\pm	0.00003
Max/Min Nickel Content	-0.00024	\pm	0.00005	$\sqrt{3}$	-0.00014	\pm	0.00003

Density

As listed in Table 2.27, the density of stainless steel 304/304L is 8.00 g/cm^3 . A 1σ uncertainty of 0.01 g/cm^3 is assumed to apply to the stainless steel density.

To find the effect of this uncertainty on the k_{eff} value, the stainless steel density was adjusted by the 3σ uncertainty. An upper perturbation k_{eff} value was found by simultaneously increasing the steel density by 0.03 g/cm^3 and then simultaneously decreasing by the same amount to find a lower perturbation k_{eff} value. Half of the difference between the upper and lower perturbation k_{eff} values was used to represent the variation in k_{eff} due to perturbing the stainless steel density by 0.03 g/cm^3 . The calculated result was then scaled to obtain the 1σ uncertainty. Results are shown in Table 2.30.

This uncertainty is treated as 100% systematic. The calculated uncertainty in the stainless steel density is considered negligible (≤ 0.00010).

Table 2.30. Effect of Uncertainty in Stainless Steel Density.

Deviation	Δk	\pm	$\sigma_{\Delta k}$	Scaling Factor	$\Delta k_{\text{eff}} (1\sigma)$	\pm	$\sigma_{\Delta k_{\text{eff}}}$
$\pm 0.03 \text{ g/cm}^3$	-0.00011	\pm	0.00005	3	-0.00004	\pm	0.00002

Dimensions – Cladding

The average fuel clad inner diameter in the 60-fuel-element core is $3.4894 \pm 0.0005 \text{ cm}$ (1σ). The cladding thickness is nominally 0.0508 cm . The clad outer diameter has a nominal reference dimension of 3.59156 cm . The reference clad tube length is 58.7375 cm (Figure 1.24). No uncertainties are provided for the reference outer diameter and length dimensions.

The effect of varying the nominal length of the fuel cladding is negligible. No perturbation analysis was performed to evaluate this parameter.

The clad inner diameter was adjusted by the 3σ uncertainty. An upper perturbation k_{eff} value was found by simultaneously increasing the clad inner diameter by 0.0015 cm and then simultaneously decreasing by the same amount to find a lower perturbation k_{eff} value. Half of the difference between the upper and lower perturbation k_{eff} values was used to represent the variation in k_{eff} due to perturbing the clad inner diameter by 0.0015 cm . The calculated result was then scaled to obtain the 1σ uncertainty. Results are shown in Table 2.31.

The clad outer diameter was adjusted by the 3σ uncertainty of the clad inner diameter. An upper perturbation k_{eff} value was found by simultaneously increasing the clad outer diameter by 0.0015 cm and then simultaneously decreasing by the same amount to find a lower perturbation k_{eff} value. Half of the difference between the upper and lower perturbation k_{eff} values was used to represent the variation in k_{eff} due to perturbing the clad outer diameter by 0.0015 cm . The calculated result was then scaled to obtain the 1σ uncertainty. Results are shown in Table 2.32.

The total number of fuel elements in this configuration is 60; therefore the random component of this uncertainty is divided by $\sqrt{60}$. The calculated uncertainty in the cladding dimensions is considered negligible (≤ 0.00010).

To evaluate the thickness of the fuel cladding, the inner and outer diameters were independently varied, overestimating the total uncertainty in the cladding thickness. However, the uncertainty in the perturbation of either of these two dimensions is negligible, indicating that the uncertainty in the thickness of the fuel cladding is also negligible.

Table 2.31. Effect of Uncertainty in Clad Inner Diameter.

Deviation	Δk	\pm	$\sigma_{\Delta k}$	Scaling Factor	$\Delta k_{\text{eff}} (1\sigma)$	\pm	$\sigma_{\Delta k_{\text{eff}}}$	Δk_{eff} (15% systematic)	Δk_{eff} (85% random)
± 0.0015 cm	-0.00016	\pm	0.00005	3	-0.00005	\pm	0.00002	-0.00001	-0.00001

Table 2.32. Effect of Uncertainty in Clad Outer Diameter.

Deviation	Δk	\pm	$\sigma_{\Delta k}$	Scaling Factor	$\Delta k_{\text{eff}} (1\sigma)$	\pm	$\sigma_{\Delta k_{\text{eff}}}$	Δk_{eff} (15% systematic)	Δk_{eff} (85% random)
± 0.0015 cm	0.00049	\pm	0.00005	3	0.00016	\pm	0.00002	0.00002	0.00002

Dimensions – End Fittings

There is insufficient information regarding all dimensions and their respective manufacturing tolerances for the stainless steel end fittings (Figures 1.29 and 1.30). The few dimensions not specified in the drawings were estimated based on the other available dimensions and the assumption of proportionality of scale between the known and unknown dimensions.

To find the effect of this uncertainty on the k_{eff} value, the stainless steel end fittings were adjusted by $>10\sigma$ uncertainty. An upper perturbation k_{eff} value was found by simultaneously doubling the end fitting volume and then simultaneously decreasing by the same amount (i.e. removing it) to find a lower perturbation k_{eff} value. Half of the difference between the upper and lower perturbation k_{eff} values was used to represent the variation in k_{eff} due to perturbing the end fitting dimensions. The calculated result was then scaled to obtain the 1σ uncertainty. Results are shown in Table 2.33.

The total number of fuel elements in this configuration is 60, each with two stainless steel end fittings; therefore the random component of this uncertainty is divided by $\sqrt{120}$. The calculated uncertainty in the total uranium mass is considered negligible (≤ 0.00010).

Table 2.33. Effect of Uncertainty in Stainless Steel End Fitting Dimensions.

Deviation	Δk	\pm	$\sigma_{\Delta k}$	Scaling Factor	$\Delta k_{\text{eff}} (1\sigma)$	\pm	$\sigma_{\Delta k_{\text{eff}}}$	Δk_{eff} (15% systematic)	Δk_{eff} (85% random)
± 100 vol.%	-0.00035	\pm	0.00005	10	-0.00004	\pm	0.00001	-0.00001	negligible

Impurities

There is no additional information regarding the uncertainty in the measured stainless steel impurity values in Table 1.11. The impurity content for elements excluding carbon, chromium, manganese, and nickel (Table 2.28) are assumed to have a bounding uncertainty (with uniform probability distribution) of $\pm 100\%$. The iron content in the steel is effectively adjusted to conserve mass while the other four elemental weight fractions mentioned above remain unchanged.

To find the effect of this uncertainty on the k_{eff} value, the impurity content was adjusted by the assumed bounding limit. An upper perturbation k_{eff} value was found by simultaneously increasing the impurity

content in all steel cladding by 100% and then simultaneously decreasing by the same amount to find a lower perturbation k_{eff} value. Half of the difference between the upper and lower perturbation k_{eff} values was used to represent the variation in k_{eff} due to perturbing the impurity content by 100%. The calculated result was then scaled to obtain the 1σ uncertainty. The calculated result was then scaled to obtain the 1σ uncertainty. Results are shown in Table 2.34.

This uncertainty is treated as 100% systematic because the actual impurity content is not recorded for any of the fuel elements in the NRAD core.

Table 2.34. Effect of Uncertainty in Stainless Steel Impurities.

Deviation	Δk	\pm	$\sigma_{\Delta k}$	Scaling Factor	$\Delta k_{\text{eff}} (1\sigma)$	\pm	$\sigma_{\Delta k_{\text{eff}}}$
$\pm 100\%$	-0.00060	\pm	0.00005	$\sqrt{3}$	-0.00035	\pm	0.00003

2.1.3.5 Air in Fuel/Cladding Gap

The reference composition and density of air is shown in Table 2.35. One volume percent of water was added to the composition and the volumetric fractions were renormalized. The computed atomic density of air is provided in Table 2.36.

Table 2.35. Typical Atmospheric Composition^(a)
by Volume, Dry Air.^(b)

Molecular Component	Content (ppm by volume) ^(c)
Nitrogen (N ₂)	780840
Oxygen (O ₂)	209460
Argon (Ar)	9340
Carbon Dioxide (CO ₂)	380
Neon (Ne)	18.18
Helium (He)	5.24
Methane (CH ₄)	1.7
Krypton (Kr)	1.14
Hydrogen (H ₂)	0.55
Surface Density (kg/m³)	1.217

(a) "Earth Fact Sheet," National Space Science Data Center, <http://nssdc.gsfc.nasa.gov/planetary/factsheet/earthfact.html>, (May 20, 2009).

(b) Water typically makes up about 1% of the composition.

(c) Numbers do not add up to exactly 100% due to round off error.

Table 2.36. Air Composition
and Atomic Density.

Element	Atoms/b-cm
H	5.0309E-07
N	3.9268E-05
O	1.0804E-05
Ar	2.3485E-07
C	9.5977E-09
Ne	4.5713E-10
He	1.3176E-10
Kr	2.8665E-11
Total	5.0820E-05

The effective bias for removing air was determined to be negligible (Section 3.1.1.1). Therefore, any uncertainty analyses regarding air were judged to be unnecessary as the results would also be negligible.

2.1.4 Control Rod Properties

2.1.4.1 Boron Carbide Absorber

Density

There is conflicting information regarding the density of the boron carbide absorber material in the control rods. The minimum density specification of 2.415 g/cm³ appears to represent a minimum requirement for NRAD operations^a while the specification of 2.48 g/cm³ represents the manufacturing minimum limit as defined by General Atomics (from design drawings, see Appendix F). The theoretical density of boron carbide is 2.52 g/cm³. The density of 2.48 g/cm³ is selected to represent the nominal density of the control rods in the NRAD reactor. The difference between the nominal and theoretical density values, +0.04 g/cm³, is selected to represent the uncertainty (bounding with uniform probability distribution) in the density of the boron carbide material.

To find the effect of this uncertainty on the k_{eff} value, the control rod absorber density was adjusted by three times the bounding limit. An upper perturbation k_{eff} value was found by simultaneously increasing the absorber density by 0.12 g/cm³ and then simultaneously decreasing by the same amount to find a lower perturbation k_{eff} value. Half of the difference between the upper and lower perturbation k_{eff} values was used to represent the variation in k_{eff} due to perturbing the absorber density by 0.12 g/cm³. The calculated result was then scaled to obtain the 1 σ uncertainty. Results are shown in Table 2.37.

This uncertainty is treated as 100% systematic. The calculated uncertainty in the boron carbide density is considered negligible (≤ 0.00010).

^a "HFEF/N Neutron Radiography Facility System Design Description," W0170-0004-SA rev. 2, Idaho National Laboratory (June 1, 1978). [This reference is not available for public release.]

Table 2.37. Effect of Uncertainty in Boron Carbide Density.

Deviation	Δk	\pm	$\sigma_{\Delta k}$	Scaling Factor	$\Delta k_{\text{eff}} (1\sigma)$	\pm	$\sigma_{\Delta k_{\text{eff}}}$
$\pm 0.12 \text{ g/cm}^3$	-0.00004	\pm	0.00005	$3\sqrt{3}$	-0.00001	\pm	0.00001

Boron Content

The manufacturing tolerance specification of boron content in the B_4C absorber (from design drawings, see Appendix F) is $78.0 \pm 1.0 \text{ wt.}\%$ with the natural occurrence of the isotope ^{10}B ($18.5 \pm 0.2 \text{ wt.}\%$). The 1.0 wt.% uncertainty in the boron content of the absorber is assumed to be a manufacturing tolerance and will be treated as a bounding uncertainty with uniform probability distribution. A boron content of $\sim 78.3 \text{ wt.}\%$ is selected to represent the experiment, based on the stoichiometric ratio of boron to carbon in B_4C .

To find the effect of this uncertainty on the k_{eff} value, the control rod absorber boron content was adjusted by three times the bounding limit. An upper perturbation k_{eff} value was found by simultaneously increasing the boron content by 3 wt.% and then simultaneously decreasing by the same amount to find a lower perturbation k_{eff} value. Half of the difference between the upper and lower perturbation k_{eff} values was used to represent the variation in k_{eff} due to perturbing the boron content by 3 wt.%. The calculated result was then scaled to obtain the 1σ uncertainty. Results are shown in Table 2.38.

This uncertainty is treated as 100% systematic. The calculated uncertainty in the boron content is considered negligible (≤ 0.00010).

Table 2.38. Effect of Uncertainty in Boron Content in Boron Carbide.

Deviation	Δk	\pm	$\sigma_{\Delta k}$	Scaling Factor	$\Delta k_{\text{eff}} (1\sigma)$	\pm	$\sigma_{\Delta k_{\text{eff}}}$
$\pm 3 \text{ wt.}\%$	-0.00004	\pm	0.00005	$3\sqrt{3}$	-0.00001	\pm	0.00001

Boron-10 Abundance

The isotopic abundance of ^{10}B in natural boron is between 19.1 and 20.3 at.% with an average value of 19.9 at.%.^a The manufacturing specification (from design drawings, see Appendix F) of $18.5 \pm 0.2 \text{ wt.}\%$ represents a much tighter requirement. The atomic abundance of 19.9 at.% ($\sim 18.43 \text{ wt.}\%$) is selected to represent the nominal isotopic abundance of ^{10}B . The $\pm 0.2 \text{ wt.}\%$ uncertainty in the isotopic abundance of ^{10}B is assumed to be bounding with uniform probability distribution.

To find the effect of this uncertainty on the k_{eff} value, the control rod absorber ^{10}B abundance was adjusted by three times the bounding limit. An upper perturbation k_{eff} value was found by simultaneously increasing the ^{10}B content by 0.6 wt.% and then simultaneously decreasing by the same amount to find a lower perturbation k_{eff} value. Half of the difference between the upper and lower perturbation k_{eff} values was used to represent the variation in k_{eff} due to perturbing the ^{10}B isotopic abundance by 0.6 wt.%. The calculated result was then scaled to obtain the 1σ uncertainty. Results are shown in Table 2.39.

This uncertainty is treated as 100% systematic. The calculated uncertainty in the isotopic abundance of ^{10}B is considered negligible (≤ 0.00010).

^a E. M. Baum, H. D. Knox, and T. R. Miller, *Nuclides and Isotopes: 16th Edition*, Knolls Atomic Power Laboratory (2002).

Table 2.39. Effect of Uncertainty in ^{10}B Abundance in Boron Carbide.

Deviation	Δk	\pm	$\sigma_{\Delta k}$	Scaling Factor	$\Delta k_{\text{eff}} (1\sigma)$	\pm	$\sigma_{\Delta k_{\text{eff}}}$
± 0.6 wt. %	-0.00004	\pm	0.00005	$3\sqrt{3}$	-0.00001	\pm	0.00001

Dimensions

The control rod absorber (Figure 1.31) length and outer diameter are 38.1 cm (no reported uncertainty) and 3.01498 cm with manufacturing tolerance limits of +0.000 and -0.0762 cm.

The effect of varying the nominal length of the control rod absorber is negligible. The manufacturing tolerance is most likely small and any uncertainty is within the uncertainty of the control rod positions (Section 2.1.1.2). No perturbation analysis was performed to evaluate this parameter.

The absorber diameter was adjusted by the twice the bounding limit. A lower perturbation k_{eff} value was found by simultaneously decreasing the clad inner diameter by 0.1524 cm. The difference between the unperturbed and lower perturbation k_{eff} values was used to represent the variation in k_{eff} due to perturbing the absorber diameter by 0.1524 cm. The calculated result was then scaled to obtain the 1σ uncertainty. Results are shown in Table 2.40.

This uncertainty is treated as 100% systematic because two of the three control rods are fully withdrawn.

Table 2.40. Effect of Uncertainty in Absorber Diameter.

Deviation	Δk	\pm	$\sigma_{\Delta k}$	Scaling Factor	$\Delta k_{\text{eff}} (1\sigma)$	\pm	$\sigma_{\Delta k_{\text{eff}}}$
± 0.1524 cm	0.00036	\pm	0.00010	$2\sqrt{3}$	0.00010	\pm	0.00003

Impurities

No impurities were reported for the boron carbide absorber in the control rods. Impurity quantities in sintered boron carbide material used elsewhere in control rods, which have an equivalent boron content, Table 2.41, were used to evaluate the effective uncertainty due to impurities in the boron carbide.

The impurities reported in Table 2.41 were added to the composition of the absorber material. The difference between the unperturbed and perturbed k_{eff} values was used to represent the variation in k_{eff} due the inclusion of impurities in the boron carbide material. Results are shown in Table 2.42.

This uncertainty is treated as a 1σ uncertainty and 100% systematic. Because the effect is practically negligible, the statistical uncertainty of 0.00010 is taken to represent the uncertainty in impurity content in the boron carbide absorber.

Table 2.41. Impurity in Sintered B₄C Pellets.^(a)

Boron Content (wt.%)	78
Impurity	Quantity (ppm wt.%)
Na	~10
Al	~1000
Si	~1000
Ca	~100
Ti	~1000
Mn	~10

(a) K. Fujii, S. Nomura, H. Imai, and M. Shindo, "Corrosion Behavior of Sintered Pellet of Graphite and Boron Carbide in Helium Containing Water Vapor," IAEA-TECDOC-690, International Atomic Energy Agency, Vienna, pp. 169-176 (February 2003).

Table 2.42. Effect of Uncertainty in Boron Carbide Impurities.

Deviation	Δk	\pm	$\sigma_{\Delta k}$	Scaling Factor	$\Delta k_{\text{eff}} (1\sigma)$	\pm	$\sigma_{\Delta k_{\text{eff}}}$
Added impurities	0.00003	\pm	0.00010	1	0.00003	\pm	0.00010

Burnup

Evaluation of the effect of the reported burnup on the control rods would require additional information such as operation history, location of the rods within the core, neutron flux, and temperature. Without this information, the next best procedure would be to use rod worth measurements to adjust the rod composition.^a There is no information available to evaluate the burnup history of the control rods during their use at PRNC. Some information is available regarding total core operation of the NRAD reactor, but insufficient to provide a complete evaluation of control rod burnup. Essentially the PRNC core history included 0.5 MW-yr on 95 fuel pins and the HEU NRAD core history included 0.25 MW-yr on 61 (and later just 60 when the water irradiation position was installed) fuel pins. Because the uncertainty in the boron content and density of the control rods is negligible, it is assumed that changes in absorber composition due to burnup would also be negligible.

2.1.4.2 Aluminum 6061 Components

Composition

The typical composition of aluminum 6061 is reported in Table 2.43. An average value for each element is selected to represent the nominal composition of aluminum, with elemental aluminum representing the balance.

^a Personal communication with Javier Ortensi at INL (April 13, 2010).

Table 2.43. Aluminum 6061-T6 Composition (wt.%).^(a)

Component	Content	Average ^(b)
Al	Balance	97.23
Cr	0.04 – 0.35	0.195
Cu	0.15 – 0.4	0.275
Fe	0.7 Max	0.35
Mg	0.8 – 1.2	1
Mn	0.15 Max	0.075
Si	0.4 – 0.8	0.6
Ti	0.15 Max	0.075
Zn	0.25 Max	0.125
Co ^(c)	0.05 Max	0.025
Ni ^(c)	0.05 Max	0.025
Sn ^(c)	0.05 Max	0.025
Density (g/cm³)	2.70	2.70

(a) ASM Aerospace Specification Metals, Inc.,
<http://www.aerospacemetals.com/>.

(b) Average based on the maximum range of each component.

(c) Reported “Other” components have a maximum of 0.15 wt.% total with no more than 0.05 wt.% per component. Co, Ni, and Sn were selected to represent impurities in Al6061.

The effective bias for removing non-aluminum elements (Table 2.43) from aluminum was determined to be negligible (Section 3.1.1.1). Therefore, any uncertainty analyses regarding the variation in composition of non-aluminum elements were judged to be unnecessary as the results would also be negligible.

Density

As listed in Table 2.43, the density of aluminum 6061 is 2.70 g/cm³. A 1 σ uncertainty of 0.01 g/cm³ is assumed to apply to the aluminum density.

To find the effect of this uncertainty on the k_{eff} value, the aluminum density was adjusted by the 3 σ uncertainty. An upper perturbation k_{eff} value was found by simultaneously increasing the aluminum density by 0.03 g/cm³ and then simultaneously decreasing by the same amount to find a lower perturbation k_{eff} value. Half of the difference between the upper and lower perturbation k_{eff} values was used to represent the variation in k_{eff} due to perturbing the aluminum density by 0.03 g/cm³. The calculated result was then scaled to obtain the 1 σ uncertainty. Results are shown in Table 2.44.

This uncertainty is treated as 100% systematic. The calculated uncertainty in the aluminum density is considered negligible (≤ 0.00010).

Table 2.44. Effect of Uncertainty in Aluminum Density.

Deviation	Δk	\pm	$\sigma_{\Delta k}$	Scaling Factor	$\Delta k_{\text{eff}} (1\sigma)$	\pm	$\sigma_{\Delta k_{\text{eff}}}$
$\pm 0.03 \text{ g/cm}^3$	0.00004	\pm	0.00005	3	0.00001	\pm	0.00002

Dimensions – Cladding

The length of the aluminum cladding is between 59.055 and 59.436 cm, with a total control rod reference length that includes end fittings of 60.96 cm. The clad tube has an outer diameter of 3.175 cm and a wall thickness of 0.07112 cm. No uncertainties are reported for the control rod cladding dimensions.

The effect of varying the nominal length of the control rod cladding is negligible, as any uncertainty is within the uncertainty of the control rod positions (Section 2.1.1.2). No perturbation analysis was performed to evaluate this parameter. The effect of varying the dimensions of the control rod aluminum end fittings would also be negligible.

The cladding thickness was adjusted by $>10\sigma$ uncertainty. An upper perturbation k_{eff} value was found by simultaneously doubling the clad thickness and then simultaneously decreasing by the same amount (i.e. removing it) to find a lower perturbation k_{eff} value. Half of the difference between the upper and lower perturbation k_{eff} values was used to represent the variation in k_{eff} due to perturbing the cladding thickness. The calculated result was then scaled to obtain the 1σ uncertainty. Results are shown in Table 2.45.

This uncertainty is treated as 100% systematic because two of the three control rods are fully withdrawn.

Table 2.45. Effect of Uncertainty in Clad Thickness.

Deviation	Δk	\pm	$\sigma_{\Delta k}$	Scaling Factor	$\Delta k_{\text{eff}} (1\sigma)$	\pm	$\sigma_{\Delta k_{\text{eff}}}$
$\pm 0.07112 \text{ cm}$	-0.00007	\pm	0.00005	10	-0.00001	\pm	0.00001

Dimensions – Guide Tubes

Guide tube dimensions are in Figure 1.35. There is insufficient information regarding manufacturing tolerances in all parts of the guide tube. A 30 vol.% (1σ) uncertainty was assumed.

To find the effect of this uncertainty on the k_{eff} value, the guide tube volume was adjusted by the 1σ uncertainty. An upper perturbation k_{eff} value was found by simultaneously increasing the guide tube volume by 30 vol.% and then simultaneously decreasing by the same amount to find a lower perturbation k_{eff} value. Half of the difference between the upper and lower perturbation k_{eff} values was used to represent the variation in k_{eff} due to perturbing the guide tube volume by 30 vol.%. Results are shown in Table 2.46.

The total number of guide tubes in this configuration is 4; therefore the random component of this uncertainty is divided by $\sqrt{4}$. The calculated uncertainty in the guide tube dimensions is considered negligible (≤ 0.00010).

Table 2.46. Effect of Uncertainty in Guide Tube Dimensions.

Deviation	Δk	\pm	$\sigma_{\Delta k}$	Scaling Factor	$\Delta k_{\text{eff}} (1\sigma)$	\pm	$\sigma_{\Delta k_{\text{eff}}}$	Δk_{eff} (15% systematic)	Δk_{eff} (85% random)
± 30 vol.%	-0.00007	\pm	0.00005	1	-0.00007	\pm	0.00005	-0.00001	-0.00003

Dimensions – End Fittings

The perturbation in the guide tube end fitting parameters was included as part of the uncertainty in the stainless steel end fittings evaluated for the fuel elements (Section 2.1.3.4), as their effective component of uncertainty is negligible.

Dimensions – Other Fittings, Parts, and Fixtures

The effective bias for removing the control rod extension rods, attachments, and internal rod fittings was determined to be negligible (Section 3.1.1.1). Therefore, any uncertainty analyses regarding these auxiliary aluminum components were judged to be unnecessary as the results would also be negligible.

Impurities

The effective bias for removing non-aluminum elements (Table 2.43) from aluminum was determined to be negligible (Section 3.1.1.1). Therefore, any uncertainty analyses regarding aluminum impurities were judged to be unnecessary as the results would also be negligible.

2.1.5 Fuel Cluster Properties

2.1.5.1 Fuel Element Pitch in Assembly

The square pitch between fuel elements within an assembly is 3.8862 cm (Figure 1.10). No uncertainty is reported for this pitch. However, the manufacturing specifications for the upper assembly components indicate a range for hole placement between 3.87604 and 3.90144 cm. There is no uncertainty reported for the tolerance of the threaded end fitting at the bottom of each fuel element. However, the tolerance should be within the manufacturing specifications provided for the assembly components, as they were designed to accommodate fuel elements with a standard threaded end fitting.

To find the effect of this uncertainty on the k_{eff} value, the fuel element pitch was adjusted by the 1σ uncertainty. An upper perturbation k_{eff} value was found by simultaneously increasing the fuel element pitch by 0.01524 cm and then simultaneously decreasing by 0.01016 cm to find a lower perturbation k_{eff} value. Half of the difference between the upper and lower perturbation k_{eff} values was used to represent the variation in k_{eff} due to perturbing the fuel element pitch within an assembly. Results are shown in Table 2.47.

The total number of fuel elements in this configuration is 60; therefore the random component of this uncertainty is divided by $\sqrt{60}$. The calculated uncertainty in the fuel element pitch within an assembly is considered negligible (≤ 0.00010).

Table 2.47. Effect of Uncertainty in Fuel Element Pitch in Assembly.

Deviation	Δk	\pm	$\sigma_{\Delta k}$	Scaling Factor	$\Delta k_{\text{eff}} (1\sigma)$	\pm	$\sigma_{\Delta k_{\text{eff}}}$	Δk_{eff} (15% systematic)	Δk_{eff} (85% random)
+0.01524 cm -0.01016 cm	0.00022	\pm	0.00005	1	0.00022	\pm	0.00005	0.00003	0.00002

This uncertainty was also evaluated using the URAN card in MCNP5.^a This card allows for the stochastic sampling of components with random locations in a lattice. The fuel elements and control rods in each assembly were simulated with random placement within ± 0.01524 cm of their nominal (x, y) placement in the cluster assemblies. The eigenvalue calculated using this method was within the statistical 1σ uncertainty of MCNP and considered negligible (≤ 0.00010).

2.1.5.2 Fuel Cluster Auxiliary Components

Steel Components

The stainless steel 304/304L average composition and density described in Table 2.27 is used to represent the material properties of the steel assembly end fittings that attach the fuel elements and control rods to the fuel cluster assemblies.

The effective bias for removing the steel end fittings was determined to be very small (Section 3.1.1.1). Therefore, any uncertainty analyses regarding the assembly components were judged to be unnecessary as the results would also be negligible.

Aluminum Components

The aluminum 6061 composition and density described in Section 2.1.4.2 is used to represent the material properties of the aluminum assembly components of the fuel cluster assemblies.

The effective bias for removing top and bottom assemblies (Figures 1.14 through 1.23) was determined to be negligible (Section 3.1.1.1). Therefore, any uncertainty analyses regarding the assembly components were judged to be unnecessary as the results would also be negligible.

2.1.6 Graphite Reflector Assembly Properties

2.1.6.1 Graphite Reflector Blocks

Composition

The composition of the graphite block reflectors (Table 2.48) is obtained by reducing the quantity of graphite to account for the impurities reported in Table 1.14. For elements that are listed only as detection limits, half of the detection limit is assumed to represent the quantity of that impurity in the graphite material.

^a X-5 Monte Carlo Team, "MCNP – A General Monte Carlo N-Particle Transport Code, Version 5, Volume II: User's Guide," LA-CP-03-0245, Los Alamos National Laboratory (October 3, 2005).

Table 2.48. Composition of Graphite Reflector Blocks.

Element	wt. %	Element	wt. %	Element	wt. %
Li	0.0000025	Ge	0.0000025	Nd	0.0000025
Be	0.0000025	As	0.0000025	Sm	0.0000005
B	0.000075	Se	0.0000025	Eu	0.0000005
C	99.968029	Br	0.000005	Gd	0.0000005
F	0.000005	Rb	0.0000025	Tb	0.0000005
Na	0.000015	Sr	0.000051	Dy	0.0000005
Mg	0.00014	Y	0.0000025	Ho	0.0000005
Al	0.00013	Zr	0.000044	Er	0.0000005
Si	0.0081	Nb	0.0000025	Tm	0.0000005
P	0.00018	Mo	0.0000025	Yb	0.0000005
S	0.005	Ru	0.0000025	Lu	0.0000005
Cl	0.00023	Rh	0.0000005	Hf	0.0000005
K	0.000005	Pd	0.0000025	Ta	0.005
Ca	0.0023	Ag	0.0000025	W	0.0000025
Sc	0.000007	Cd	0.0000025	Re	0.0000005
Ti	0.0018	In	0.0000025	Os	0.0000005
V	0.0029	Sn	0.0000025	Ir	0.0000005
Cr	0.000025	Sb	0.0000025	Pt	0.0000005
Mn	0.000012	Te	0.0000025	Au	0.000005
Fe	0.0055	I	0.0000005	Hg	0.000005
Co	0.0000005	Cs	0.0000025	Tl	0.0000025
Ni	0.00035	Ba	0.0000025	Pb	0.0000025
Cu	0.0000025	La	0.0000025	Bi	0.0000025
Zn	0.0000025	Ce	0.0000025	Th	0.0000025
Ga	0.0000005	Pr	0.0000025	U	0.0000025

Density

The average measured density of the graphite reflector blocks (Table 1.13) is $1.570 \pm 0.009 \text{ g/cm}^3$ (1σ). According to ASTM C838-96 (2005),^a the within-laboratory variation on density is 0.28% with a between-laboratory variation of 0.81%, indicating a possible, but unconfirmed, bias for the method used to determine the density of graphite. These percentages represent density uncertainties of ± 0.004 and $\pm 0.013 \text{ g/cm}^3$, respectively.

To find the effect of this uncertainty on the k_{eff} value, the graphite reflector block density was adjusted by the 3σ uncertainty. An upper perturbation k_{eff} value was found by simultaneously increasing the graphite density by 0.027 g/cm^3 and then simultaneously decreasing by the same amount to find a lower

^a ASTM C838-96, Standard Test Method for Bulk Density of As-Manufactured Carbon and Graphite Shapes.

perturbation k_{eff} value. Half of the difference between the upper and lower perturbation k_{eff} values was used to represent the variation in k_{eff} due to perturbing the graphite density by 0.027 g/cm^3 . The calculated result was then scaled to obtain the 1σ uncertainty. Results are shown in Table 2.49.

This uncertainty is treated as 100% systematic instead of $\sim 50\%$ because it is not completely clear how much of a systematic uncertainty to expect when using this method. Furthermore, six samples were taken from a single block and it is assumed that all graphite blocks have the same density as the sampled block. Variation in density between blocks is unknown.

Table 2.49. Effect of Uncertainty in Graphite Block Density.

Deviation	Δk	\pm	$\sigma_{\Delta k}$	Scaling Factor	$\Delta k_{\text{eff}} (1\sigma)$	\pm	$\sigma_{\Delta k_{\text{eff}}}$
$\pm 0.027 \text{ g/cm}^3$	0.00060	\pm	0.00005	3	0.00020	\pm	0.00002

Dimensions

The length of the graphite portion of the graphite reflector blocks (Figure 1.37) is $65.7225 \pm 0.3175 \text{ cm}$ (manufacturing tolerance). The square cross section of the block (Figure 1.37) is 7.366 cm with manufacturing tolerance limits of $+0.000$ and -0.254 cm . The four corners are chamfered: $0.9525 \pm 0.0762 \text{ cm} \times 45 \pm 5^\circ$.

The graphite block length was adjusted by the manufacturing tolerance. An upper perturbation k_{eff} value was found by simultaneously increasing the length of all graphite blocks by 0.3175 cm and then simultaneously decreasing by the same amount to find a lower perturbation k_{eff} value. Half of the difference between the upper and lower perturbation k_{eff} values was used to represent the variation in k_{eff} due to perturbing the graphite block length by 0.3175 cm . The calculated result was then scaled to obtain the 1σ uncertainty. Results are shown in Table 2.50.

The graphite block cross sectional area was adjusted by the manufacturing tolerance. A lower perturbation k_{eff} value was found by simultaneously decreasing the square area by 0.254 cm and increasing the chamfer depth by 0.0762 cm for all graphite blocks. Half of the difference between the unperturbed and lower perturbation k_{eff} values was used to represent the variation in k_{eff} due to perturbing the graphite block cross sectional area. The calculated result was then scaled to obtain the 1σ uncertainty. Results are shown in Table 2.51.

The total number of graphite blocks in this configuration is 12; therefore the random component of this uncertainty is divided by $\sqrt{12}$. The uncertainty in the cross sectional area of the graphite blocks is divided by $\sqrt{2}$ to represent the two main sides of the block as being independently cut. No correction was implemented for the adjustment in chamfer dimensions. The angle of the chamfers was unchanged.

Table 2.50. Effect of Uncertainty in Graphite Block Length.

Deviation	Δk	\pm	$\sigma_{\Delta k}$	Scaling Factor	$\Delta k_{\text{eff}} (1\sigma)$	\pm	$\sigma_{\Delta k_{\text{eff}}}$	Δk_{eff} (15% systematic)	Δk_{eff} (85% random)
$\pm 0.3175 \text{ cm}$	0.00001	\pm	0.00010	$\sqrt{3}$	0.00001	\pm	0.00006	0.00001	0.00001

Table 2.51. Effect of Uncertainty in Graphite Block Area.

Deviation	Δk	\pm	$\sigma_{\Delta k}$	Scaling Factor	$\Delta k_{\text{eff}} (1\sigma)$	\pm	$\sigma_{\Delta k_{\text{eff}}}$	Δk_{eff} (15% systematic)	Δk_{eff} (85% random)
\pm BL	-0.00143	\pm	0.00010	$\sqrt{2}\sqrt{3}$	-0.00058	\pm	0.00004	-0.00009	-0.00014

The effective bias for removing aluminum 2011 parts, the AmBe source, and their respective holes was determined to be negligible (Section 3.1.1.1). Therefore, any uncertainty analyses regarding the holes in the graphite were judged to be unnecessary as the results would also be negligible.

Impurities

The effective bias for removing impurities from the graphite reflector (Table 1.48) was determined to be negligible (Section 3.1.1.1). Therefore, any uncertainty analyses regarding the impurities in the graphite were judged to be unnecessary as the results would also be negligible.

Water Saturation Effects

Many of the graphite blocks have been underwater since the original installation of the NRAD reactor (>30 years) and a few others were added in 1981 and 1989 (>20 years). The blocks were each removed once to exchange the top and bottom assembly adapters with newer components before being placed back into the tank.^a It is currently unknown whether there is any saturation of water within the graphite matrix. The maximum possible amount of water saturation is ~30 vol.%. This was estimated by dividing the mass density of the graphite reflector blocks, 1.57 g/cm³, by the theoretical mass density of graphite, ~2.25 g/cm³, and subtracting the volume fraction from 100% to get the maximum theoretical void fraction. Calculations were performed with volumetric additions of water homogeneously dispersed in the graphite reflector block matrix up to 30 vol.%. The effective increase in core reactivity is shown in Table 2.52 and Figure 2.1.

Because it is uncertain how much water saturation, if any, exists in the graphite blocks, the maximum difference at 30 vol.% is assumed to represent a bounding uncertainty with uniform probability distribution. This uncertainty is treated as 100% systematic because it is believed all graphite blocks would exhibit the same quantity of saturation. The effective uncertainty due to water saturation in the graphite blocks is shown in Table 2.53.

Table 2.52. Effect of Water Saturation of Graphite.

Deviation	Δk	\pm	$\sigma_{\Delta k}$
+5 vol.% H ₂ O	0.00083	\pm	0.00010
+10 vol.% H ₂ O	0.00194	\pm	0.00010
+15 vol.% H ₂ O	0.00253	\pm	0.00010
+20 vol.% H ₂ O	0.00294	\pm	0.00010
+25 vol.% H ₂ O	0.00322	\pm	0.00010
+30 vol.% H ₂ O	0.00359	\pm	0.00010

^a Personal communication with Ken Schreck at HFEF (September 2, 2010).

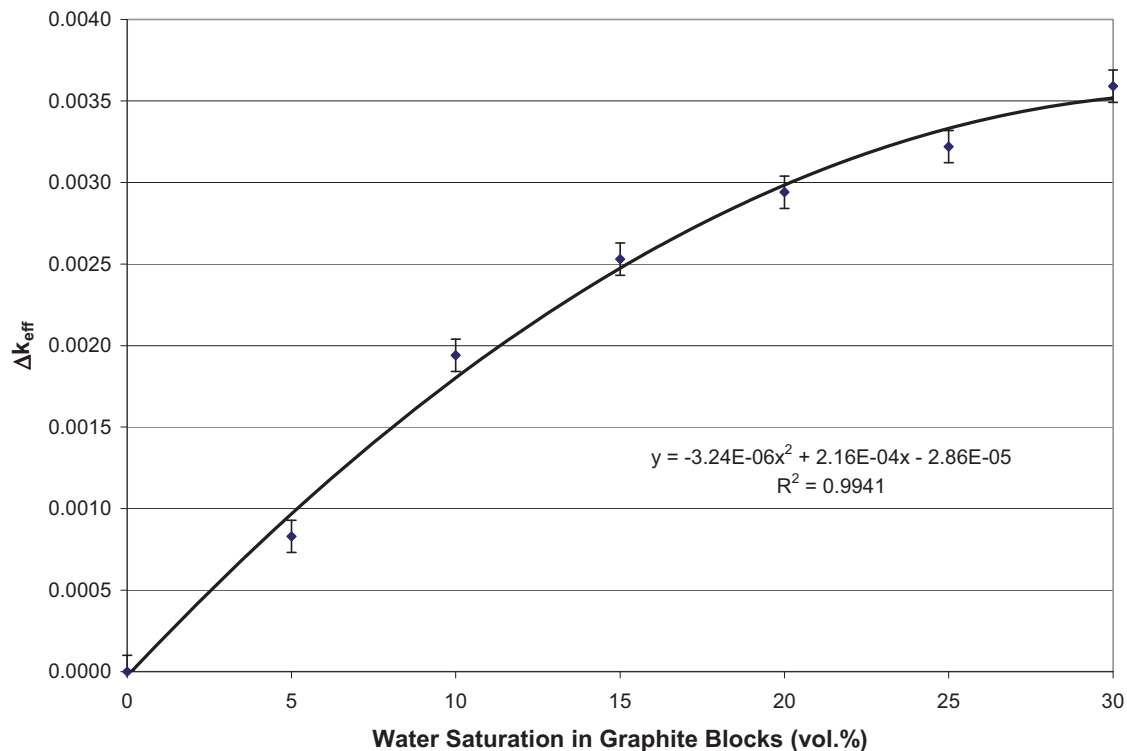

Figure 2.1. Effect of Water Saturation of Graphite.

Table 2.53. Effect of Uncertainty in Water Saturation of Graphite.

Deviation	Δk	\pm	$\sigma_{\Delta k}$	Scaling Factor	$\Delta k_{\text{eff}} (1\sigma)$	\pm	$\sigma_{\Delta k_{\text{eff}}}$
+30 vol.% H ₂ O	0.00359	\pm	0.00010	$\sqrt{3}$	0.00207	\pm	0.00006

2.1.6.2 Graphite Reflector Assembly Auxiliary Components

Aluminum 2011-T3 Components

The composition and density of aluminum 2011-T3 is reported in Table 2.54. An average composition was selected to represent the tie rod, dowel, and screw components in the graphite reflector block assemblies.

Table 2.54. Aluminum 2011-T3 Composition (wt.%).

Component	Content 1 ^(a)	Content 2 ^(b)	Average ^(c)
Al	93.7	Balance	92.925
Bi	0.20 – 0.60	0.2 – 0.6	0.4
Cu	5.0 – 6.0	5 – 6	5.5
Fe	0.70 Max	0.7 Max	0.35
Si	0.40 Max	0.4 Max	0.2
Pb	0.20 – 0.60	0.2 – 0.6	0.4
Zn	0.30 Max	0.3 Max	0.15
Co ^(d)	--	0.05 Max	0.025
Ni ^(d)	--	0.05 Max	0.025
Sn ^(d)	--	0.05 Max	0.025
Density (g/cm³)	2.82	2.83	2.82

(a) Alcoa Toolrite 2011®-T3 Aluminum, MatWeb Material Property Data, <http://www.matweb.com/>.

(b) Metal Suppliers Online, <http://www.metalsuppliersonline.com/>.

(c) Average based on the maximum range of each component.

Values of 0.25 wt.% are selected for Fe and Si to satisfy the combined maximum requirement of <0.95 wt.% and an Al content of >99 wt.%.

(d) Reported "Other" components have a maximum of 0.15 wt.% total with no more than 0.05 wt.% per component. Co, Ni, and Sn were selected to represent impurities in Al6061.

The effective bias for removing aluminum 2011 parts (Figure 1.36) and their respective holes was determined to be negligible (Section 3.1.1.1). Therefore, any uncertainty analyses regarding the aluminum 2011 parts were judged to be unnecessary as the results would also be negligible.

Aluminum 6061 Components

The aluminum 6061 composition and density described in Section 2.1.4.2 is used to represent the material properties of the aluminum assembly components of the graphite reflector block assemblies.

The effective bias for removing top and bottom assemblies (Figures 1.14, 1.36, and 1.38) was determined to be negligible (Section 3.1.1.1). Therefore, any uncertainty analyses regarding the assembly components were judged to be unnecessary as the results would also be negligible.

2.1.6.3 Americium-Beryllium Source and Tube

AmBe Source and Steel Cladding

The only information available regarding the source (Figure 1.51) is the source strength of 5 Ci ($\sim 1 \times 10^7$ neutrons/sec) on 5/10/1968 and a stainless steel container that is 3.302 cm long and 2.032 cm in outer diameter. In the design drawing for the graphite reflector assembly containing the source, the container is 3.50266 cm long with an outer diameter of 2.0955 cm. It is assumed that the stainless steel cladding is SS304/304L material with the average composition and density found in Table 2.27. The cladding is assumed to be one-sixteenth inches thick (0.15875 cm) on all sides and the source container is a right cylinder with no additional features. Therefore the approximate volume of the source and cladding is 12.08 cm³ and the approximate volume of just the source region within the clad is 7.91 cm³.

The activity of the source was evaluated by decaying the 5 Ci source from the initial date to 3/30/2010 (41.92 years) with an americium half-life of 432.7 years. The source had, at the time of the initial experiments, a strength of ~4.7 Ci (1.73×10^{11} alphas/s). This is equivalent to a neutron emission rate of approximately 5.2×10^6 neutrons/s assuming 30 neutrons are emitted per one million alpha particles in an AmBe source.^a

The exact chemical composition of the AmBe source is unknown. A different 5 Ci source of unspecified origin (purchased in 1986) was dismantled, sampled (sub-sampled), and analyzed using inductively coupled plasma mass spectrometry (ICP-MS) at the Idaho National Laboratory. The source was comprised of three separate pellets of varying thickness and mass. Each pellet was sub-sampled to provide 10 samples ranging in size from 6 to 15 mg.^b The results of the analyses are in Table 2.55.

Table 2.55. Example AmBe Source Properties.^(a)

Be:Am Ratio	$6.30 \pm 52\% (1\sigma)$
%Pu in ²⁴¹Am	0.157
%²³⁹Pu	$72.7 \pm 0.4\%$
%²⁴⁰Pu	$27.3 \pm 2\%$
U:Pu Ratio	$0.177 \pm 120\%$
²³⁸U Isotopic Content^(b)	$90 \pm 1\%$
Impurities^(c)	ng/mg ²⁴¹Am (or ppm) $\pm 10\% (2\sigma)$
Sc	1470
Sr	1590
Y	1480
Zr	1610
Mo	1830
Ba	1830
W	313

(a) J. Sommers, M. Jimenez, M. Adamic, J. Giglio, and K. Carney, "Characterization of a Sealed Americium-Beryllium (AmBe) Source by Inductively Coupled Plasma Mass Spectrometry," *J. Radioanal. Nucl. Chem.*, **282**, 929-932 (2009).

(b) This value represents a variance weighted average of the original data: $98 \pm 2\%$, $84 \pm 3\%$, $95 \pm 3\%$, and $88 \pm 1\%$.

(c) Only the impurities of significant measurable content were reported.

Assuming the AmBe source is homogeneously distributed under vacuum conditions within the interior volume of the source cladding, the atomic density of the americium can be calculated directly from the current activity of the source at the time of the experiments. The additional data provided in Table 2.55

^a D. R. Lide, ed., *CRC Handbook of Chemistry and Physics, 90th Edition (Internet Version 2010)*, CRC Press/Taylor and Francis, Boca Raton, FL (2010).

^b J. Sommers, M. Jimenez, M. Adamic, J. Giglio, and K. Carney, "Characterization of a Sealed Americium-Beryllium (AmBe) Source by Inductively Coupled Plasma Mass Spectrometry," *J. Radioanal. Nucl. Chem.*, **282**, 929-932 (2009).

can be used to estimate the approximate composition of the AmBe source material. There is assumed to be no ^{237}Np in the initial source, and that all ^{237}Np is obtained via the decay of ^{241}Am with no decay of any other radioisotopes in the source. It is assumed that all actinides are in the dioxide form such that an approximate content of oxygen can be included in the material composition. The estimated composition of the AmBe source is shown in Table 2.56. The approximate mass density of this homogenized source is 0.251 g/cm^3 .

Table 2.56. Smearred AmBe Source
Composition and Atomic Density.

Isotope/Element	Atoms/b-cm
^{241}Am	4.3062E-04
Be	2.7129E-03
^{237}Np	2.9906E-05
^{239}Pu	4.9228E-07
^{240}Pu	1.8486E-07
^{235}U	1.1985E-08
^{238}U	1.0787E-07
O	9.2265E-04
Sc	3.3943E-06
Sr	1.8837E-06
Y	1.7280E-06
Zr	1.8320E-06
Mo	1.9800E-06
Ba	1.3833E-06
W	1.7672E-07
Total	4.1093E-03

The effective bias for removing the encapsulated AmBe source (Figure 1.51), source tube (Figure 1.52), and cap (Figure 1.53) was determined to be negligible (Section 3.1.1.1). Therefore, any uncertainty analyses regarding the AmBe source were judged to be unnecessary as the results would also be negligible.

Source Tube and Cap

The composition of the source tube and source tube cap is aluminum 6061 with the composition and density as described in Table 2.43.

The effective bias for removing the encapsulated AmBe source (Figure 1.51), source tube (Figure 1.52), and cap (Figure 1.53) was determined to be negligible (Section 3.1.1.1). Therefore, any uncertainty analyses regarding the source tube and cap were judged to be unnecessary as the results would also be negligible.

2.1.7 Grid Plate Properties

2.1.7.1 Aluminum 1100

The composition and density of aluminum 1100 is reported in Table 2.57. An average composition was selected to represent the core grid plate material properties.

Table 2.57. Aluminum 1100 Composition (wt.%).

Component	Content 1 ^(a)	Content 2 ^(b)	Average ^(c)
Al	99.00 Min	99 Min	99.225
Cu	0.05 – 0.20	0.05 – 0.2	0.125
Fe	1.0 Max	--	0.25
Mn	0.05 Max	0.05 Max	0.025
Si	1.0 Max	--	0.25
Zn	0.10 Max	0.1 Max	0.05
Fe + Si	--	0.95 Max	0.5
Co ^(d)	0.05	0.05	0.025
Ni ^(d)	0.05	0.05	0.025
Sn ^(d)	0.05	0.05	0.025
Density (g/cm³)	--	2.71	2.71

(a) All Metals & Forge, <http://www.steelforge.com/>.

(b) Metal Suppliers Online,
<http://www.metalsuppliersonline.com/>.

(c) Average based on the maximum range of each component. Values of 0.25 wt.% are selected for Fe and Si to satisfy the combined maximum requirement of <0.95 wt.% and an Al content of >99 wt.%.

(d) Reported “Other” components have a maximum of 0.15 wt.% total with no more than 0.05 wt.% per component. Co, Ni, and Sn were selected to represent impurities in Al6061.

The effective bias for removing the grid plate (Figure 1.10) was determined to be negligible (Section 3.1.1.1). Therefore, any uncertainty analyses regarding the grid plate itself were judged to be unnecessary as the results would also be negligible.

2.1.7.2 Assembly Pitch in Grid Plate

The square pitch between fuel elements within an assembly is 8.10006 cm in the East-West direction and 7.7089 cm in the North-South direction (Figure 1.11). No uncertainty is reported for this pitch. However, the manufacturing specifications for the grid plate assembly indicate a manufacturing tolerance of ± 0.0127 cm in the location of the center of each hole (Figure 1.10). The assembly hole diameter in the grid plate is 6.1722 cm with manufacturing tolerance limits of +0.01778 and -0.00508 cm (Figure 1.10). The bottom assembly adapters (Figure 1.14) have a diameter of 6.0706 ± 0.0254 cm (manufacturing limit).

To find the effect of this uncertainty on the k_{eff} value, the assembly pitch in the grid plate was adjusted by the bounding limit of ± 0.1016 cm, which represents the difference between the nominal diameters of the

bottom assembly adapters and the assembly holes in the grid plate. An upper perturbation k_{eff} value was found by simultaneously increasing the assembly pitch by 0.1016 cm and then simultaneously decreasing by the same amount to find a lower perturbation k_{eff} value. Half of the difference between the upper and lower perturbation k_{eff} values was used to represent the variation in k_{eff} due to perturbing the assembly pitch by 0.1016 cm. The calculated result was then scaled to obtain the 1σ uncertainty. Results are shown in Table 2.58.

The calculated uncertainty in the nominal pitch is then scaled to account for uncertainties in the location of the holes drilled into the grid plate, the diameter of the assembly holes in the grid plate, and the diameter of the bottom assembly adapters. The uncertainty in the location of the drilled holes is accounted for twice because it is assumed that the location of one hole is independent from the location of an adjacent hole. All uncertainties related to the assembly pitch are believed to exhibit some randomness. However, the uncertainty in the diameter of the holes in the grid plate is assumed to be 100% systematic, as a single drill bit would have been used to make them.

The total number of assemblies in this configuration is 28 (16 fuel clusters and 12 graphite blocks); therefore the random component of this uncertainty is divided by $\sqrt{28}$. The calculated uncertainty in the assembly pitch is considered negligible (≤ 0.00010) except for that due to the difference in assembly adapter and hole dimensions and the drilled diameter of the holes in the grid plate.

Table 2.58. Effect of Uncertainty in Fuel Assembly Pitch.

Deviation	Δk	\pm	$\sigma_{\Delta k}$	Scaling Factor	$\Delta k_{\text{eff}} (1\sigma)$	\pm	$\sigma_{\Delta k_{\text{eff}}}$	Δk_{eff} (15% systematic)	Δk_{eff} (85% random)
± 0.1016 cm	0.00278	\pm	0.00005	$2\sqrt{3}^{(a)}$	0.00080	\pm	0.00001	0.00012	0.00013
				$8\sqrt{3}^{(b)}$	0.00020	\pm	0.00000	0.00003	0.00003
				$8\sqrt{3}^{(b)}$	0.00020	\pm	0.00000	0.00003	0.00003
				$5.7 \times 2\sqrt{3}^{(c)}$	0.00014	\pm	0.00000	--	--
				$4 \times 2\sqrt{3}^{(d)}$	0.00019	\pm	0.00000	0.00003	0.00003

- (a) This scaling factor represents adjustment of the perturbed quantity to the uncertainty in assembly placement due to the difference in assembly bottom diameter and grid plate hole diameter.
- (b) This scaling factor represents adjustment of the perturbed quantity to the uncertainty in the location of the grid position in the grid plate.
- (c) This scaling factor represents adjustment of the perturbed quantity to the uncertainty in the diameter of assembly holes drilled into the grid plate.
- (d) This scaling factor represents adjustment of the perturbed quantity to the uncertainty in the diameter of the bottom assembly adapter.

This uncertainty was also evaluated using the URAN card in MCNP5.^a This card allows for the stochastic sampling of components with random locations in a lattice. The fuel and graphite assemblies in the core were simulated with random placement within ± 0.01016 cm of their nominal (x, y) placement in the grid plate. The effect calculated using this method was $0.00005 \pm 0.00003 \Delta k_{\text{eff}} (1\sigma)$, which is negligible (≤ 0.00010). Analysis using this method indicates that the method employed to obtain the results in Table 2.58 may overestimate the total effective uncertainty in the assembly pitch. However, the calculated uncertainty in the assembly pitch is still quite small compared to other uncertainties in this reactor configuration.

^a X-5 Monte Carlo Team, "MCNP – A General Monte Carlo N-Particle Transport Code, Version 5, Volume II: User's Guide," LA-CP-03-0245, Los Alamos National Laboratory (October 3, 2005).

2.1.8 Ex-Core Structural Support Properties

2.1.8.1 Grid Support Structure

The aluminum 6061 composition and density described in Section 2.1.4.2 is used to represent the material properties of the aluminum grid support structure.

The effective bias for removing the grid support structure (Figure 1.8) was determined to be negligible (Section 3.1.1.1). Therefore, any uncertainty analyses regarding the support structure were judged to be unnecessary as the results would also be negligible.

2.1.8.2 Mounting Pad

The aluminum 6061 composition and density described in Section 2.1.4.2 are used to represent the material properties of the aluminum mounting pad.

The effective bias for removing the mounting pad (Figures 1.5 and 1.9) was determined to be negligible (Section 3.1.1.1). Therefore, any uncertainty analyses regarding the mounting pad were judged to be unnecessary as the results would also be negligible.

2.1.8.3 Reactor Tank

The aluminum 6061 composition and density described in Section 2.1.4.2 is used to represent the material properties of the aluminum reactor tank.

The effective bias for removing the reactor tank (Figures 1.5 and 1.9) was determined to be negligible (Section 3.1.1.1). Therefore, any uncertainty analyses regarding the mounting pad were judged to be unnecessary as the results would also be negligible.

2.1.9 Tank Water Properties

Composition

The tank water composition is assumed to be pure with the stoichiometric ratio of hydrogen to oxygen. 2:1.

Density

The density of water, at a given temperature in degrees Celsius, can be obtained by interpolation of data tables provided in the 90th edition of the *CRC Handbook of Chemistry and Physics*,^a or calculated using an equation provided in the 70th edition of the handbook:^b

$$\rho \left(\frac{\text{kg}}{\text{m}^3} \right) = \frac{\left(999.83952 + 16.945176 \cdot T - 7.9870401 \cdot 10^{-3} \cdot T^2 - 46.170461 \cdot 10^{-6} \cdot T^3 \right) + 105.56302 \cdot 10^{-9} \cdot T^4 - 280.54253 \cdot 10^{-12} \cdot T^5}{\left(1 + 16.879850 \cdot 10^{-3} \cdot T \right)}$$

^a D. R. Lide, ed., *CRC Handbook of Chemistry and Physics, 90th Edition (Internet Version 2010)*, CRC Press/Taylor and Francis, Boca Raton, FL (2010).

^b R. C. Weast and D. R. Lide, eds., *CRC Handbook of Chemistry and Physics, 70th Edition*, CRC Press, Boca Raton, FL (1990).

Use of either method provides a density within less than 0.0006% of the density obtained using the other method. The density of water at the temperature of 27.2°C is 0.9965 g/cm³. The uncertainty in water density is evaluated and discussed as the uncertainty in the experiment temperature (Section 2.1.1.1). Any additional uncertainty incurred through use of the handbook data or equation for water density is assumed to be negligible.

Impurities

The tank water in the Advanced Test Reactor (ATR, [ATR-FUND-RESR-001](#)) is considered “dirtier” than the NRAD tank water. The reported impurity concentration for the ATR is found in Table 2.59.

The impurities reported in Table 2.59 were added to the composition of the tank water. The difference between the unperturbed and perturbed k_{eff} values was used to represent the variation in k_{eff} due to the inclusion of impurities in the water. Results are shown in Table 2.60.

This uncertainty is treated as a 1σ uncertainty and 100% systematic. Because the effect is practically negligible, the statistical uncertainty of 0.00010 is taken to represent the uncertainty in impurity content in the water.

Table 2.59. Impurities in ATR Tank Water.^(a)

Element	Concentration (ppb)
Fe	0.84
Al	2.02
Ca	49.00
Mg	5.30
Mb	0.37
Si	29.40
Na	36.10
Cu	0.33
Pb	0.20
Be	0.23
Cr	54.50
Sr	0.35
Ni	175.00
Co	0.30

(a) [ATR-FUND-RESR-001](#).

Table 2.60. Effect of Uncertainty in Water Impurities.

Deviation	Δk	\pm	$\sigma_{\Delta k}$	Scaling Factor	$\Delta k_{\text{eff}} (1\sigma)$	\pm	$\sigma_{\Delta k_{\text{eff}}}$
Added impurities	0.00003	\pm	0.00010	1	0.00003	\pm	0.00010

2.1.10 Beam Tube Properties

2.1.10.1 Aluminum 6061

Composition and Density

The aluminum 6061 composition and density described in Section 2.1.4.2 is used to represent the material properties of the aluminum reactor tank.

Dimensions – Beam Filter Tube

The outer height of the East and North beam filter tubes (Figure 1.42) is 16.51 cm with a manufacturing tolerance for the East tube is +0.000 and -0.0254 cm, and ± 0.0762 cm for the North tube. The top and bottom aluminum walls are manufactured from 0.635-cm-thick stock material. The width of both tubes is 13.97 cm with a manufacturing tolerance of +0.000 and -0.0254 cm, with the side aluminum walls manufactured from 0.3175-cm-thick stock material. The front face aluminum plate, placed near the core, is manufactured from 0.2286-cm-thick stock material. No tolerances are available for the stock material thicknesses. It is assumed that all beam filter tube dimensions are bound, with uniform probability distribution, within a tolerance of ± 0.0762 cm, which is the largest manufacturing uncertainty tolerance for the aluminum parts comprising the beam filter tubes.

The beam tube aluminum volume was adjusted by the maximum manufacturing tolerance. An upper perturbation k_{eff} value was found by simultaneously increasing the outside dimensions (and decreasing the inside dimensions) by 0.0762 cm and then simultaneously decreasing (increasing) by the same amount to find a lower perturbation k_{eff} value. Half of the difference between the upper and lower perturbation k_{eff} values was used to represent the variation in k_{eff} due to perturbing the beam tube volume by 0.0762 cm. The calculated result was then scaled to obtain the 1σ uncertainty. Results are shown in Table 2.61.

The total number of beam tubes in this configuration is 2; therefore the random component of this uncertainty is divided by $\sqrt{2}$. The uncertainty in the beam tube dimensions is divided by $\sqrt{4}$ to correct for the thickness of four main sides of each tube being perturbed simultaneously. The uncertainty in the placement of the beam tube in relation to the core face is assessed in Section 2.1.10.4. The calculated uncertainty in the beam tube aluminum dimensions is negligible (≤ 0.00010).

Table 2.61. Effect of Uncertainty in Aluminum Thickness.

Deviation	Δk	\pm	$\sigma_{\Delta k}$	Scaling Factor	$\Delta k_{\text{eff}} (1\sigma)$	\pm	$\sigma_{\Delta k_{\text{eff}}}$	Δk_{eff} (15% systematic)	Δk_{eff} (85% random)
± 0.0762 cm	0.00006	\pm	0.00005	$\sqrt{4}\sqrt{3}$	0.00002	\pm	0.00001	negligible	0.00002

Dimensions – Other Aluminum Beam Tube Components

The effective bias for removing the beam tube aluminum (Figures 1.40 through 1.49), excluding the beam filter tube, was determined to be negligible (Section 3.1.1.1). Therefore, any uncertainty analyses regarding aluminum dimensions of the beam tube components (excluding the beam filter tube) were judged to be unnecessary as the results would also be negligible.

Impurities

The effective bias for removing non-aluminum elements (Table 2.43) from aluminum was determined to be negligible (Section 3.1.1.1). Therefore, any uncertainty analyses regarding aluminum impurities were judged to be unnecessary as the results would also be negligible.

2.1.10.2 Gas Content in Beam Filter Tubes

The gas content in the East beam filter tube is air with a composition and density as described in Section 2.1.3.5. The gas content in the North beam filter tube and both beam line aperture mechanism housing and beam tubes is helium with a pressure of approximately 0.2 atm at 300.35 K. The helium is assumed to be pure gas with a calculated atomic density of 1.2209×10^{-6} atoms/b-cm (mass density of 8.1149×10^{-6} g/cm³).

$$\frac{n}{V} = \frac{P \cdot N_A}{R \cdot T} = \frac{(0.2 \text{ atm}) \cdot \left(0.60221 \frac{\text{atoms} \cdot \text{cm}^2}{\text{mol} \cdot \text{b}}\right)}{\left(82.05746 \frac{\text{cm}^3 \cdot \text{atm}}{\text{mol} \cdot \text{K}}\right) \cdot (300.35 \text{ K})} = 1.2209 \cdot 10^{-6} \frac{\text{atoms}}{\text{b} \cdot \text{cm}}$$

$$\rho = \frac{n}{V} \cdot \frac{M}{N_A} = 1.2209 \cdot 10^{-6} \frac{\text{atoms}}{\text{b} \cdot \text{cm}} \cdot \frac{4.0026 \frac{\text{g}}{\text{mol}}}{\left(0.60221 \frac{\text{atoms} \cdot \text{cm}^2}{\text{mol} \cdot \text{b}}\right)} = 8.1149 \cdot 10^{-6} \frac{\text{g}}{\text{cm}^3}$$

The effective bias for removing air and helium was determined to be negligible (Section 3.1.1.1). Therefore, any uncertainty analyses regarding air were judged to be unnecessary as the results would also be negligible.

2.1.10.3 Boron Nitride Apertures

The aperture blocks are Combat Grade A boron nitride from the graphite products division of The Carborundum Co., which is now Saint-Gobain.^a Typical impurities and the physical density for this material is provided in Table 2.62.

^a Saint-Gobain Advanced Ceramics, Boron Nitride Products, 168 Creekside Drive, Amherst, New York 14228, <http://www.bn.saint-gobain.com>.

Table 2.62. Composition of Combat
Grade A Boron Nitride.^(a)

Component	Average ppm (wt.%)
Al	14.6
Au	1
Be	1
Ca	620.8
Cr	22.8
Cu	1
Fe	1
K	23
Mg	1
Mn	1.4
Mo	1
Na	20
Ni	1
Pb	1
Si	2410.6
Sn	1
Ti	1
V	1
W	1
Zn	1
Zr	1
B ₂ O ₃ ^(b)	4.56 wt.%
O ₂ ^(b)	4.30 wt.%
BN	Balance
Density (g/cm ³)	2.09 ^(c)

(a) Personal communication with Steve Lyle at Saint-Gobain Boron Nitride (April 21, 2010).

(b) The oxygen quantities overlap some between these two measurements.

(c) Density in a single billet can vary as much as 7-8% from this average value within the billet.

The effective bias for removing the boron nitride apertures (Figures 1.43 and 1.44) was determined to be negligible (Section 3.1.1.1). Therefore, any uncertainty analyses regarding boron nitride were judged to be unnecessary as the results would also be negligible.

2.1.10.4 Placement of Beam Lines Relative to Core Fuel Elements

The front face of the beam line filter tubes (Figures 1.41 and 1.42) was approximately 2.032 cm from the outside clad face of the outermost fuel elements in the core. There is no reported uncertainty in this parameter. This distance is a function of core properties such as fuel element pitch within an assembly, fuel assembly pitch, and fuel element outer diameter and beam line properties such as total beam filter tube length, thickness of the beam filter tube attachment region, total thickness of the beam aperture mechanism region, alignment accuracy of the beam mechanism region to the beam tube support stand, and alignment accuracy of the beam line support stand attached to the floor with respect to the location of the core.

The uncertainties due to core parameters are already included with the evaluation of their respective uncertainties in previous sections. The uncertainty in the length of the beam filter tube is ± 0.0381 cm. The uncertainty in the thickness of the beam filter tube attachment plate is ± 0.00762 cm. The uncertainty in the thickness of the front face aluminum sheet of the aperture mechanism region is assumed to be ± 0.0762 cm. The uncertainty in the thickness of the beam aperture mechanism region is assumed to be half of the tolerance value: $\pm 0.0381/2$ (0.01905) cm. The uncertainty in the alignment accuracy of the attachment of the aperture mechanism region to the support stand and the support stand to the tank floor, with respect to the core, are both assumed to be ± 0.0762 cm. All of these uncertainties are treated as bounding uncertainties with uniform probability distribution. The total maximum position uncertainty for the distance between the core face and the face of the beam filter tube is ± 0.29337 cm. Assuming that each aspect of the beam line hardware manufacture and placement is independent, this maximum value is divided by the square-root of the number of components, six (6), and the actual bounding uncertainty in the distance between the core and beam filter tube is approximately ± 0.12 cm. This uncertainty is equivalent to assuming a 0.05 in. uncertainty in the original 0.8 in. approximate distance.

To find the effect of this uncertainty on the k_{eff} value, the locations of the beam lines were adjusted by their estimated bounding limit. An upper perturbation k_{eff} value was found by simultaneously increasing the distance by 0.12 cm and then simultaneously decreasing by the same amount to find a lower perturbation k_{eff} value. Half of the difference between the upper and lower perturbation k_{eff} values was used to represent the variation in k_{eff} due to perturbing the locations of the beam lines. The calculated result was then scaled to obtain the 1σ uncertainty. Results are shown in Table 2.63.

The total number of beam tubes in this configuration is 2; therefore the random component of this uncertainty is divided by $\sqrt{2}$.

Table 2.63. Effect of Uncertainty in Beam Line Placement.

Deviation	Δk	\pm	$\sigma_{\Delta k}$	Scaling Factor	$\Delta k_{\text{eff}} (1\sigma)$	\pm	$\sigma_{\Delta k_{\text{eff}}}$	Δk_{eff} (15% systematic)	Δk_{eff} (85% random)
± 0.12 cm	0.00040	\pm	0.00005	$\sqrt{3}$	0.00023	\pm	0.00003	0.00003	0.00014

Uncertainty in the centerline alignment of the beam line with the core fuel is expected to be small and have a negligible effect on the total k_{eff} uncertainty. Any uncertainty due to centerline alignment of the beam tube would already be included in the dimensional analysis of the beam filter tube aluminum walls.

2.1.11 Instrumentation and Detector Properties

2.1.11.1 Dry Tubes, Detectors, etc.

Dry tubes were not installed during the initial critical measurements of the NRAD core; uncertainty analyses were therefore not performed.

The effective bias for removing the detectors and their housings from the benchmark model was not performed because they are beyond the water reflector boundaries determined in Section 3.1.1.1. The detectors are sufficiently distanced from the core so as to not directly influence criticality. Therefore, any uncertainty analyses regarding the detectors were judged to be unnecessary as the results would be negligible.

2.1.12 Total Experimental Uncertainty

2.1.12.1 60-Fuel-Element Core Critical Configuration

A compilation of the total evaluated uncertainty in the 60-fuel-element core critical configuration of the NRAD reactor is shown in Table 2.64. As discussed earlier, uncertainties that are not treated as 100% systematic because perturbation analyses were simultaneously applied to multiple components are treated as 15% systematic (to preserve some uncertainty due to possible, yet unknown, systematic effects) and 85% random. In the case of the ^{235}U enrichment, the systematic component of the uncertainty was determined to be 25%. The random portion of the uncertainty is then divided by the square root of the number of perturbed components. The root-mean square of each subcomponent is taken to determine the uncertainty in either the random or systematic components of the total evaluated uncertainty. The total evaluated uncertainty is then the root-mean square of the random and systematic uncertainties.

Uncertainties ≤ 0.00010 are reported as negligible (neg) and those with no evaluated random component of the total uncertainty are noted with "--". The most significant contribution to the overall uncertainty is the degree of water saturation in the graphite reflector blocks. All uncertainties providing at least 0.04 % Δk_{eff} are highlighted in gray.

Table 2.64. Total Experimental Uncertainty of the 60-Fuel-Element NRAD Core.

Perturbed Parameter	Parameter Value	1 σ Uncertainty	$\pm\Delta k_{\text{eff}}$ (1 σ) Systematic	$\pm\Delta k_{\text{eff}}$ (1 σ) Random
Temperature (°C)	26	±2	neg	--
Control Rod Positions (cm)	38.1, 38.1, 20.4216	±0.0508	neg	--
Total Fuel Element Mass (g)	2506.5	±0.1	neg	neg
Uranium Mass (g)	749.9	±0.1	neg	neg
²³⁵ U Mass (g)	148.0	±0.43	0.00014	0.00012
²³² U Content (wt.%)	~0	--	neg	--
²³⁴ U Content (wt.%)	0.18	±0.02	0.00031	--
²³⁶ U Content (wt.%)	0.22	±0.09	0.00046	--
Fuel Element Length (cm)	38.02	±0.04	neg	neg
Fuel Element ID (cm)	0.635	+0, -0.0254/ $\sqrt{3}$	neg	neg
Fuel Element OD (cm)	3.4805	±0.0003	neg	neg
Hydrogen/Zirconium Ratio	1.58	±0.01	0.00015	0.00011
Hydride Homogeneity	1.58	±0.03	neg	neg
Erbium Content in Fuel (wt.%)	0.90	±0.02	0.00040	0.00029
Carbon Content in Fuel (wt.%)	0.30	±0.02	neg	neg
Hafnium Content in Fuel (wt.%)	0.008	±0.008/ $\sqrt{3}$	neg	--
EBC in Fuel (wt.%)	0.000104	0.000015	neg	--
Zirconium Density (g/cm ³)	6.51	±0.01	neg	--
Zirconium Rod Diameter (cm)	0.5715	+0, -0.0254/ $\sqrt{3}$	neg	neg
Zirconium Impurities	Table 2.18	-100%	neg	--
Molybdenum Density (g/cm ³)	10.22	±0.02	neg	--
Molybdenum Volume	Figure 1.27	--	neg	neg
Molybdenum Impurities	Table 2.21	-100%	neg	--
Axial Graphite Density (g/cm ³)	1.73	±0.01	neg	--
Axial Graphite Volume	Figure 1.28	--	neg	neg
Axial Graphite Impurities	Table 2.24	-100%	neg	--
Stainless Steel Carbon Content	Table 2.27	Table 2.27	neg	--
Stainless Steel Chromium Content	Table 2.27	Table 2.27	neg	--
Stainless Steel Manganese Content	Table 2.27	Table 2.27	0.00066	--
Stainless Steel Nickel Content	Table 2.27	Table 2.27	0.00014	--
Stainless Steel Density (g/cm ³)	8.00	±0.01	neg	--
Steel Cladding Length (cm)	58.7375	--	neg	neg
Steel Cladding ID (cm)	3.4894	±0.0005/ $\sqrt{3}$	neg	neg
Steel Cladding OD (cm)	3.59156	±0.0005/ $\sqrt{3}$	neg	neg
Steel End Fitting Volume	Figures 1.29 and 1.30	±100%	neg	neg

Table 2.64 (cont'd.). Total Experimental Uncertainty of the 60-Fuel-Element NRAD Core.

Perturbed Parameter	Parameter Value	1 σ Uncertainty	$\pm\Delta k_{\text{eff}}$ (1 σ) Systematic	$\pm\Delta k_{\text{eff}}$ (1 σ) Random
Stainless Steel Impurities	Table 2.28	$\pm 100\%$	0.00035	--
Air Composition and Density	Tables 2.35 and 2.36	--	neg	--
Boron Carbide Density (g/cm ³)	2.48	$+0.04/\sqrt{3}$	neg	--
B ₄ C Boron Content (wt.%)	78.3	$\pm 1.0/\sqrt{3}$	neg	neg
¹⁰ B Abundance (wt.%)	18.43	$\pm 0.2/\sqrt{3}$	neg	--
Absorber Length (cm)	38.1	--	neg	neg
Absorber Diameter (cm)	3.01498	+0, - $0.0762/\sqrt{3}$	neg	--
B ₄ C Impurities	none	Table 2.41	0.00010	neg
Control Rod Burnup	--	--	neg	--
Aluminum 6061 Composition	Table 2.43	--	neg	--
Aluminum 6061 Density (g/cm ³)	2.70	± 0.01	neg	--
Aluminum Clad Length (cm)	60.96	--	neg	neg
Aluminum Clad Thickness (cm)	0.07112	$\pm 100\%$	neg	--
Guide Tube Volume (vol.%)	Figure 1.35	$\pm 30\%$	neg	neg
Guide Tube End Fitting Volume	Figure 1.35	$\pm 100\%$	neg	neg
Auxiliary Control Rod Parts	Figures 1.31 and 1.33	-100%	neg	--
Aluminum 6061 Impurities	Table 2.43	-100%	neg	--
Fuel Element Pitch in Assembly (cm)	3.8862	$+0.01524/\sqrt{3}$ $-0.01016/\sqrt{3}$	neg	neg
Fuel Cluster Assembly Parts	Figures 1.14 through 1.18	-100%	neg	neg
Graphite Block Density (g/cm ³)	1.570	± 0.009	0.00020	--
Graphite Block Length (cm)	65.7225	$\pm 0.3175/\sqrt{3}$	neg	neg
Graphite Block Cross Section (cm ²)	Figure 1.37	Figure 1.37	neg	0.00014
Graphite Block Impurities	Table 2.48	-100%	neg	neg
Water Saturation of Graphite (vol.%)	0	$+30\%/\sqrt{3}$	0.00207	--
Aluminum 2011 Components	Figure 1.36 and Table 2.54	-100%	neg	--
Graphite Assembly Parts	Figures 1.14 and 1.38	-100%	neg	--
AmBe Source Properties	Figure 1.51 and Table 2.56	-100%	neg	--
Source Tube and Cap Properties	Figures 1.52 and 1.53 and Table 2.43	-100%	neg	--

Table 2.64 (cont'd.). Total Experimental Uncertainty of the 60-Fuel-Element NRAD Core.

Perturbed Parameter	Parameter Value	1σ Uncertainty	$\pm\Delta k_{\text{eff}}$ (1σ) Systematic	$\pm\Delta k_{\text{eff}}$ (1σ) Random
Aluminum 1100 Grid Plate	Figure 1.9 and Table 2.57	-100%	neg	--
Assembly Pitch in Grid Plate (cm)	8.10006 E-W 7.7089 N-S	$\pm 0.0508/\sqrt{3}$	0.00012	0.00013
Location of Holes in Grid Plate (cm)	Figure 1.10	$\pm 0.0127/\sqrt{3}$	neg	neg
Assembly Hole Diameter (cm)	6.1722	$+0.01778/\sqrt{3}$ $-0.00508/\sqrt{3}$	0.00014	--
Bottom Assembly Diameter (cm)	6.0706	$\pm 0.0254/\sqrt{3}$	neg	neg
Grid Plate Support Structure	Figure 1.8	-100%	neg	--
Mounting Pad	Figure 1.5	-100%	neg	--
Reactor Tank	Figure 1.5	-100%	neg	--
Water Impurities	None	Table 2.59	0.00010	--
Beam Tube Aluminum Properties	Table 2.43	--	neg	--
Beam Filter Tube Dimensions (cm)	Figure 1.42	$\pm 0.0762/\sqrt{4}/\sqrt{3}$	neg	neg
Other Beam Tube Aluminum Parts	Figures 1.41	--	neg	--
Beam Tube Aluminum Impurities	Table 2.43	--	neg	--
Gas Content in Beam Tubes	--	-100%	neg	--
Boron Nitride Apertures	Figures 1.43 and 1.44 and Table 2.62	-100%	neg	--
Placement of Beam Lines (cm)	2.032	$\pm 0.12/\sqrt{3}$	neg	0.00014
Instrumentation and Detectors	Figures 1.55 and 1.56	--	neg	neg
Uncertainty by Type	--	--	0.00234	0.00041
Total Experimental Uncertainty	--	--	0.00238	--

2.1.12.2 56-Fuel-Element Core Critical Configuration

Evaluation of the uncertainty in the 56-fuel-element core critical configuration was performed after the comprehensive analysis of the 60-fuel-element core. Because most of the uncertainties evaluated for the 60-fuel-element core were negligible (see Table 2.64) only a small selection of uncertainties were evaluated for the 56-fuel-element core. The uncertainties for the 56-fuel-element core were evaluated in an identical manner as discussed in their respective subsections above. A summary of the total evaluated uncertainty in the 56-fuel-element core critical configuration of the NRAD reactor is provided in Table 2.65. The discussion provided in Section 2.1.12.1 in regards to the uncertainties in Table 2.64 also apply in Table 2.65. Most of the uncertainties between the two core configurations are comparable within statistical uncertainties. The notable difference is the increased worth of water saturation in the graphite blocks. The 56-fuel-element core has a smaller, tighter core that is more sensitive to water content in the reflector region.

Table 2.65. Total Experimental Uncertainty of the 56-Fuel-Element NRAD Core.

Perturbed Parameter	Parameter Value	1σ Uncertainty	$\pm\Delta k_{\text{eff}}$ (1σ) Systematic	$\pm\Delta k_{\text{eff}}$ (1σ) Random
²³⁵ U Mass (g)	147.9	± 0.43	0.00014	0.00012
²³⁴ U Content (wt.%)	0.18	± 0.02	0.00029	--
²³⁶ U Content (wt.%)	0.22	± 0.09	0.00043	--
Hydrogen/Zirconium Ratio	1.58	± 0.01	0.00015	0.00011
Erbium Content in Fuel (wt.%)	0.90	± 0.02	0.00040	0.00030
Stainless Steel Manganese Content	Table 2.27	Table 2.27	0.00073	--
Stainless Steel Nickel Content	Table 2.27	Table 2.27	0.00017	--
Stainless Steel Impurities	Table 2.28	$\pm 100\%$	0.00036	--
B ₄ C Impurities	None	Table 2.41	0.00019	neg
Graphite Block Density (g/cm ³)	1.570	± 0.009	0.00023	--
Graphite Block Cross Section (cm ²)	Figure 1.37	Figure 1.37	neg	0.00014
Water Saturation of Graphite (vol.%)	0	$+30\%/\sqrt{3}$	0.00248	--
Assembly Pitch in Grid Plate (cm)	8.10006 E-W 7.7089 N-S	$\pm 0.0508/\sqrt{3}$	0.00011	0.00012
Assembly Hole Diameter (cm)	6.1722	$+0.01778/\sqrt{3}$ $-0.00508/\sqrt{3}$	0.00013	--
Water Impurities	None	Table 2.59	0.00026	--
Placement of Beam Lines (cm)	2.032	$\pm 0.12/\sqrt{3}$	neg	0.00011
Uncertainty by Type	--	--	0.00274	0.00041
Total Experimental Uncertainty	--	--	0.00277	--

2.2 Evaluation of Buckling and Extrapolation Length Data

Buckling and extrapolation length measurements were not made.

2.3 Evaluation of Spectral Characteristics Data

Spectral characteristics measurements were not made.

2.4 Evaluation of Reactivity Effects Data

Benchmark models provided in Section 3.1, for the 56- and 60-fuel-element core configurations, were utilized with model perturbations simulating control rod movements, as discussed in Section 3.4, to calculate the worths reported in Section 1.4. Calculations were also performed using the detailed models provided in Appendix C to evaluate simplification biases. As discussed in Section 3.4.1, the bias simplifications in the benchmark models (Section 3.1.1.1) had a negligible impact on the calculated worths.

Measurements reported in Table 1.15 were not evaluated because detailed information regarding the additional detectors placed in the core during start-up was not available. As the start-up measurements were repeated for a cleaner core without the extra detectors, the values reported in Table 1.16 are instead used in this benchmark.

Measurements reported in Tables 1.18 and 1.19 are repeated measurements for some of the data reported in Table 1.17. As these are duplicate measurements, and very nearly identical to the original set of measurements, they are not evaluated. Instead they are used to demonstrate the low uncertainty in measurement reproducibility (see Section 2.4.2).

Reactivity effects measurements evaluated include a total of fifteen measurements (six control rod worths, two shutdown margins, two core excess reactivities, four graphite reflector block worths, and the worth of the experiment dry tube); they are determined to be acceptable benchmark experiments.

Uncertainties in the measured data were not provided and have been evaluated in this section. Worths measured during the start-up measurements were typically reported in absolute values. The convention taken in this report is the use of negative values for reporting measurements that reduce the neutron population via absorption (control rods, shutdown margins, reflector block removal, and insertion of the dry tube) and positive values for effects that increase the population (positive period measurements and excess reactivities).

2.4.1 Delayed Neutron Fraction, β_{eff}

Reactivity worths for NRAD measurements are typically reported in \$ or ϕ . Staff historically use a β_{eff} value of 0.0071 to convert reactivity measurements to and from Δk . General Atomics utilizes a β_{eff} value of 0.0078 in their design analysis of the NRAD reactor.^a Reported values for the delayed neutron fraction in TRIGA-type reactors have been known to range between 0.0070 and 0.0080.^{b,c,d,e} The delayed neutron fraction is typically insensitive to reflector material.^c

Calculations were performed to assess the variability in β_{eff} for the NRAD reactor (see Appendix I). A median value of 0.0075 ± 0.000375 was selected for all reactivity measurements in both core configurations. Because all reported reactivity measurement worths were reported in units of \$ using a β_{eff} value of 0.0071, they will be adjusted for the selected β_{eff} value of 0.0075 for comparison with calculations and for use as benchmark measurements.

2.4.2 Uncertainties in Rod Worth Measurements

Typically the uncertainty in the measurement method is much greater than any uncertainties obtained via computational analysis of geometry and composition perturbations in the benchmark models, such as the comprehensive evaluation performed in Section 2.1 for the critical configurations.

As evaluated in Section 2.1.1.2, and discussed elsewhere in a separate analysis of a TRIGA reactor,^f the slight vertical movements and changes in position of the control rods is minor for most worth calculations, $<1 \phi$. The uncertainty in the control rod positions is assumed to be included within the uncertainty in the method.

Comparison of Tables 1.17 through 1.19 for the three sets of measurements to determine the regulating rod worth (partial rod drop combined with positive period measurements), core excess reactivity, and shutdown margin of the 60-fuel-element core, demonstrate that the uncertainty in measurement repeatability in the NRAD reactor is also very small, $<1 \phi$.

2.4.2.1 Rod Drop Method

The excitation of a multiplying system, such as a critical reactor, by a rapid change of state, such as a rod drop, will generate short-lived flux modes that are not characteristic of the fundamental mode of the system. However, on the time scales of minutes, the typical period over which rod drop measurements are performed and measured, these harmonics are generally negligible.^g

^a "LEU Upgrade of the NRAD Reactor, Final Report," 911193 rev. 0, GA Project 39296, TRIGA Reactor Division of General Atomics (August 27, 2010). [This reference is not available for public release.]

^b A. Trkov, M. Ravnik, H. Boeck, and B. Glumac, "Reactivity Measurements in a Close-to-Critical TRIGA Reactor Using a Digital Reactivity Meter," *Kerntechnik*, **57**, 296-300 (1992).

^c M. T. Simnad, F. C. Foushee, and G. B. West, "Fuel Elements for Pulsed TRIGA[®] Research Reactors," *Nucl. Technol.*, **28**, 31-56 (1976).

^d L. Snoj, A. Kavčič, G. Žerovnik, and M. Ravnik, "Calculation of Kinetic Parameters for Mixed TRIGA Cores with Monte Carlo," *Ann. Nucl. Energy*, **37**, 223-229 (2010).

^e T. Matsumoto, "Benchmark Analysis of Criticality Experiments in the TRIGA Mark II Using a Continuous Energy Monte Carlo Code MCNP," *J. Nucl. Sci. Technol.*, **35**, 662-670 (1998).

^f I. Mele, M. Ravnik, and A. Trkov, "TRIGA Mark II Benchmark Experiment, Part I: Steady-State Operation," *Nucl. Technol.*, **105**, 37-51 (1994).

^g T. Williams, M. Rosselet, and W. Scherer (eds.), "Critical Experiments and Reactor Physics Calculations for Low-Enriched High Temperature Gas Cooled Reactors," IAEA-TEC-DOC-1249, International Atomic Energy Agency, Vienna, Austria (2001).

The prompt rod drop method is the easiest way to estimate the reactivity change in a reactor core; this method is based on the prompt flux adjustment that occurs directly after a perturbation, and assumes that the delayed neutron source is constant compared to the initial state. This method is sensitive to spatial effects and less accurate than other methods. Typical uncertainties are on the order of 5-6 % for a TRIGA reactor.^a

Uncertainties in the rod drop technique on the order of 5-6 % in the MASURCA reactor^b and HTR-PROTEUS critical assembly^c have also been reported. The dominant systematic uncertainty is in the kinetic constants and flux perturbations with the statistical component of the uncertainty <1 %.

Common uncertainties for the rod insertion method include uncertainties in the delayed neutron data, which is systematic and common to all measuring methods. Another uncertainty source is in the flux redistribution in the subcritical core. As mentioned previously, the changes in flux is dominated by the long-lived delayed neutron precursors, whose distribution closely resembled that of the critical reactor shortly after the perturbation of the core. The most significant uncertainty source is the flux redistribution in the presence of control rods, i.e., rod shadowing effects. The positions of the control rods in the reactor impact the worth of the rod being measured. The uncertainty in this method is reported to be 3-5 % for individual control rod worths, with a statistical error of <0.2 %. However, the impact of the interference due to the presence of other control rods increases the estimated uncertainty to ~10 %.^d

The rod insertion method is very similar to the rod drop method, except that the control rods are driven into the core instead of dropped. It has been shown that flux perturbation effects due to control rods present in the core (rod shadowing) can impact the measured worth of a control rod by more than 30 %. On average, however, the reported values for this analysis of a TRIGA reactor varied ~8 % and the core operated with most of the control rods partially inserted into the core,^e unlike the NRAD reactor. Comparison of the full regulating rod drop worth with the regulating rod worth obtained from the measured partial drop and partial period measurements gives a difference of ~7 %.

An uncertainty of 10 % is selected to represent the uncertainty in the rod drop measurement method for this benchmark analysis.

^a C. Jammes, B. Geslot, R. Rosa, G. Imel, and P. Fougeras, "Comparison of Reactivity Estimations Obtained from Rod-Drop and Pulsed Neutron Source Experiments," *Ann. Nucl. Energy*, **32**, 1131-1145 (2005).

^b G. Perret, C. Jammes, G. Imel, C. Destouches, P. Chaussonnet, J. M. Laurens, R. Soule, G. M. Thomas, W. Assal, P. Fougeras, P. Blaise, J-P. Hudelot, H. Philibert, and G. Bignan, "Determination of Reactivity by a Revised Rod-Drop Technique in the MUSE-4 Programme – Comparison with Dynamic Measurements," *7th Information Exchange Meeting on Actinide and Fission Product Partitioning and Transmutation*, Juja, Korea, October 14-16 (2002).

^c M. Rosselet and R. Chawla, "Epithermal Inverse Kinetic Measurements and Their Interpretation Using a Two-Group Point-Kinetic Model," *Nucl. Sci. Eng.*, **135**, 33-47 (2000).

^d I. Mele, M. Ravnik, and A. Trkov, "TRIGA Mark II Benchmark Experiment, Part II: Pulse Operation," *Nucl. Technol.*, **105**, 52-58 (1994).

^e A. Trkov, M. Ravnik, H. Wimmer, B. Glumac, and H. Böck, "Application of the Rod-Insertion Method for Control Rod Worth Measurements in Research Reactors," *Kerntechnik*, **60**, 255-261 (1995).

2.4.2.2 Positive Period Method

The positive period method is also referred to as the rod exchange method, where the rod worth is measured relative to another, calibrated, control rod, or stepwise movements of the rod are measured with a reactivity meter. Calibration curve measurements in a TRIGA reactor have shown that the uncertainty in rod exchange measurements are slightly <10 %. The uncertainty includes uncertainties in control rod positions, interference effects from other control rods during the measurement (rod shadowing), and statistical errors from reactivity calculated by the reactivity meter; the latter of which are negligible.^a

Due to the severe local flux distribution deformation in rod exchange measurements, simulations need to model the effects correctly for each measurement step. An uncertainty of 10 % is typical for this type of measurement,^b and has become the standard for treating the uncertainty in reactivity measurements in other TRIGA reactors.^c

An uncertainty of 10 % is selected to represent the uncertainty in the positive period measurement method for this benchmark analysis.

2.4.2.3 Combined and Difference Worth Measurements

The total worth of the regulating control rod is typically obtained by combining the measured worths for a partial rod drop and positive period measurements. The worth of the graphite reflector blocks and the experiment dry tube were obtained by comparing the difference in core excess reactivity of two core configurations using positive period measurements. Uncertainties in these measured worths were obtained by propagating the uncertainties in the individual measurements used to determine the given worths. As discussed elsewhere, the exact core configuration, including control rod positions, typically needs to be modeled to reproduce the fission source distribution in the experiment in order to perform calculations that more precisely simulate the measured conditions.^c This effectively reduces biases and uncertainties introduced by incorrectly evaluating the measured experimental data.

2.4.3 Control Rod Worths

Control rod withdrawn positions reported in Tables 1.16 through 1.20 are converted from their reported location in units into centimeters, where one “unit” represents 0.0381 cm (0.015 in.) of rod travel. Rods reported to have been withdrawn 999 or 1000 units are considered fully withdrawn at a position of 38.1 cm. Reported worth values are multiplied by 10 % to obtain their measurement uncertainty, as discussed in Section 2.4.2. As stated in Section 2.4.1, all reported worths are converted from worths obtained with a β_{eff} value of 0.0071 to worths obtained with a value of 0.00750 ± 0.000375 (5 %, 1σ) by multiplying the given values by the ratio 0.0071/0.0075. The uncertainties in the measured worths and β_{eff} are combined (via root-mean square) to obtain the total uncertainty in the adjusted experimental worth data. The adjusted values are provided in the following subsections.

^a I. Mele, M. Ravnik, and A. Trkov, “TRIGA Mark II Benchmark Experiment, Part II: Pulse Operation,” *Nucl. Technol.*, **105**, 52-58 (1994).

^b R. Jeraj, B. Glumac, and M. Maučec, “Monte Carlo Simulation of the TRIGA Mark II Benchmark Experiment,” *Nucl. Technol.*, **120**, 179-187 (1997).

^c T. Matsumoto and N. Hayakawa, “Benchmark Analysis of TRIGA Mark II Reactivity Experiment Using a Continuous Energy Monte Carlo Code MCNP,” *J. Nucl. Sci. Technol.*, **37**, 1082-1087 (2000).

2.4.3.1 Rod Drop Measurements

Partial and full rod worth measurements were performed for the 56-fuel-element core (Table 1.16), 60-fuel-element core (Table 1.17), and variations of the 60-fuel-element core with graphite reflector blocks removed (Table 1.20). The adjusted control rod worths, their positions, and their 1σ uncertainties are shown in Table 2.66.

Table 2.66. Adjusted Control Rod Worths Obtained via Rod Drop Measurements.

Core Description	Shim 1 Position (cm)	Shim 2 Position (cm)	Reg Start Position (cm)	Reg End Position (cm)	Measurement Type	Adjusted Worth		
						$\rho\%$	\pm	1σ
56 Fuel Elements	38.1	38.1	29.5656	--	Shim 1 Drop	-2.76	\pm	0.31
				--	Shim 2 Drop	-2.72	\pm	0.30
				0.0	Partial Reg Drop	-2.06	\pm	0.23
60 Fuel Elements	38.1	38.1	20.4216	--	Shim 1 Drop	-2.68	\pm	0.30
				--	Shim 2 Drop	-2.75	\pm	0.33
				0.0	Partial Reg Drop	-1.21	\pm	0.14
	26.8224	26.8224	38.1	0.0	Full Reg Drop	-2.50	\pm	0.28
60 Fuel Elements (Block A-5 Out)	38.1	38.1	22.0599	0.0	Partial Reg Drop	-1.38	\pm	0.15
60 Fuel Elements (Block C-1 Out)	38.1	38.1	24.9936	0.0	Partial Reg Drop	-1.67	\pm	0.19
60 Fuel Elements (Block D-1 Out)	38.1	38.1	25.1460	0.0	Partial Reg Drop	-1.69	\pm	0.19
60 Fuel Elements (Block F-4 Out)	38.1	38.1	24.6507	0.0	Partial Reg Drop	-1.51	\pm	0.17

2.4.3.2 Positive Period Measurements

Positive period measurements were performed for the 56-fuel-element core (Table 1.16), 60-fuel-element core (Table 1.17), and variations of the 60-fuel-element core with graphite reflector blocks removed (Table 1.20). Positive period measurements are performed in a series of steps to obtain the total core excess reactivity. Individual steps are only reported in Tables 1.16 and 1.17 for the 56- and 60-fuel-element cores, respectively, and not for the variations of the core with graphite reflector blocks removed. The latter core measurements only report the sum of the positive period measurements. The sum of the positive period measurements is evaluated as an excess reactivity measurement in Section 2.4.5. The adjusted positive period measurements, their positions, and their 1σ uncertainties are shown in Table 2.67.

Table 2.67. Adjusted Positive Period Measurements.

Core Description	Shim 1 Position (cm)	Shim 2 Position (cm)	Reg Start Position (cm)	Reg End Position (cm)	Measurement Type	Adjusted Worth		
						$\rho\%$	\pm	1σ
56 Fuel Elements	38.1	38.1	29.4513	31.6992	Positive Period	0.14	\pm	0.02
	35.6616	35.6616	31.6992	34.4043		0.13	\pm	0.01
	34.0614	34.0614	34.4043	38.1		0.11	\pm	0.01
60 Fuel Elements	38.1	38.1	20.4216	21.9837	Positive Period	0.15	\pm	0.02
	35.3568	35.3568	21.9837	23.8125		0.17	\pm	0.02
	33.2994	33.2994	23.8125	25.6794		0.17	\pm	0.02
	31.6230	31.6230	25.6794	27.6987		0.16	\pm	0.02
	30.2133	30.2133	27.6987	30.0228		0.16	\pm	0.02
	28.9941	28.9941	30.0228	32.5755		0.14	\pm	0.02
	27.9273	27.9273	32.5755	34.6329		0.08	\pm	0.01
	27.3939	27.3939	34.6329	38.1		0.09	\pm	0.01

2.4.3.3 Combined Worth Measurements

The partial rod drop measurements for the regulating rod are combined with the sum of the positive period measurements (evaluated in the previous two subsections) to obtain the total worth of the regulating control rod. The adjusted regulating rod worths and their 1σ uncertainties are shown in Table 2.68. The worth of the regulating rod obtained using this combination of methods is less than the worth obtained by performing a full rod drop measurement (Table 2.67); this discrepancy is most likely due to flux redistribution effects due to control rod movements in the two methods. The regulating rod worth is practically the same using either method when the magnitude in the measurement uncertainties are accounted for. An average regulating rod worth for the 60-fuel-element core is obtained using these two measurements (Table 2.69).

Whereas the results for the individual steps performed for the positive period measurements were not available for the cases where graphite reflector blocks were removed from the core, the uncertainty of ± 0.05 \$, obtained for the sum of the positive period measurements in the 60-fuel-element core with all reflector blocks in-core, was used to represent the uncertainty. The core configurations are very similar and the method to obtain these measurements was identical.

Table 2.68. Adjusted Regulating Rod Combined Worth Measurements.

Core Description	Partial Rod Drop Worth			Total Positive Period Worth			Adjusted Worth		
	$\rho\text{\$}$	\pm	1σ	$\rho\text{\$}$	\pm	1σ	$\rho\text{\$}$	\pm	1σ
56 Fuel Elements	-2.06	\pm	0.23	0.37	\pm	0.02	-2.43	\pm	0.23
60 Fuel Elements	-1.21	\pm	0.14	1.12	\pm	0.05	-2.33	\pm	0.14
60 Fuel Elements (Block A-5 Out)	-1.38	\pm	0.16	0.95	\pm	0.05	-2.34	\pm	0.16
60 Fuel Elements (Block C-1 Out)	-1.67	\pm	0.19	0.71	\pm	0.05	-2.38	\pm	0.19
60 Fuel Elements (Block D-1 Out)	-1.69	\pm	0.19	0.69	\pm	0.05	-2.38	\pm	0.19
60 Fuel Elements (Block F-4 Out)	-1.51	\pm	0.17	0.67	\pm	0.05	-2.18	\pm	0.17

Table 2.69. Average Regulating Rod Worth for the 60-Fuel-Element Core.

Measurement Description	Adjusted Worth		
	$\rho\text{\$}$	\pm	1σ
Full Rod Drop	-2.50	\pm	0.28
Partial Rod Drop with Positive Period Measurements	-2.33	\pm	0.14
Average Value	-2.42	\pm	0.16

2.4.4 Shutdown Margin

The shutdown margin (SDM) is defined as the negative reactivity of the core present when all control elements have been fully inserted to achieve minimum core multiplication.^a It can be simply calculated as the worth of the control rods withdrawn from the core or the total worth of all control rods minus the remaining core excess reactivity. The adjusted shutdown margins and their 1σ uncertainties are shown in Table 2.70. The shutdown margin for the 56-fuel-element core is obtained by summing the worth of the two fully dropped shim rods and the partial worth of the partially drop regulating rod; the worth of each rod was measured separately. The shutdown margin for the 60-fuel-element core was obtained via two methods: 1) the method described for the 56-fuel-element core and 2) the summation of all three fully dropped rods minus the core excess reactivity. The two SDMs measured for the 60-fuel-element core are similar within their respective uncertainties; therefore, an average value was calculated.

Table 2.70. Adjusted Shutdown Margins ($\rho\beta \pm 1\sigma$).

Core Description	56 Fuel Elements		60 Fuel Elements	
	Method 1	Shim 1	-2.76 \pm 0.31	Shim 1
Shim 2		-2.72 \pm 0.30	Shim 2	-2.75 \pm 0.33
Partial Reg		-2.06 \pm 0.23	Partial Reg	-1.21 \pm 0.14
SDM		-7.54 \pm 0.49	SDM	-6.65 \pm 0.46
Method 2	--	--	Shim 1	-2.68 \pm 0.30
	--	--	Shim 2	-2.75 \pm 0.33
	--	--	Reg	-2.50 \pm 0.28
	--	--	ER	1.12 \pm 0.13
	--	--	SDM	-6.81 \pm 0.53
--	--	Average	-6.73 \pm 0.47	

^a J. J. Duderstadt and L. J. Hamilton, *Nuclear Reactor Analysis*, John Wiley & Sons, Ann Arbor, Michigan (1976).

2.4.5 Excess Reactivity

Excess reactivity (ER) is defined as the core reactivity present with all control elements withdrawn from the core.^a It can be simply calculated as the worth of the control rods remaining in the core when the core is in a critical state or the total worth of all control rods minus the core shutdown margin. Core excess reactivity is obtained by summing the positive period measurements (Section 2.4.3.2); the adjusted excess reactivity values and their 1σ uncertainties are shown in Table 2.71. The total uncertainty is obtained by propagating the uncertainties from the individual positive period measurements and not by taking a 10 % uncertainty in the total measured excess reactivity worth, which would overestimate the total uncertainty. As discussed in Section 2.4.3.3, the individual positive period measurements were not available for the cases where graphite reflector blocks were removed from the core; the uncertainty in these cases is expected to be identical to the uncertainty determined for the 60-fuel-element core.

Table 2.71. Adjusted Excess Reactivities.

Core Description	Excess Reactivity		
	$\rho\%$	\pm	1σ
56 Fuel Elements	0.37	\pm	0.02
60 Fuel Elements	1.12	\pm	0.05
60 Fuel Elements (Block A-5 Out)	0.95	\pm	0.05
60 Fuel Elements (Block C-1 Out)	0.71	\pm	0.05
60 Fuel Elements (Block D-1 Out)	0.69	\pm	0.05
60 Fuel Elements (Block F-4 Out)	0.67	\pm	0.05

2.4.6 Graphite Reflector Block Worths

The worths of the graphite blocks were obtained by comparing the excess reactivity of the 60-fuel-element core, with all blocks included, with the excess reactivity for a nearly identical core configuration with a single graphite block removed. The withdrawn position of the regulating rod changes and positive period measurements are performed to determine the core excess reactivity. The adjusted graphite reflector block worths and their 1σ uncertainties are shown in Table 2.72.

Table 2.72. Adjusted Graphite Reflector Block Worths.

Block	Block Worth		
	$\rho\%$	\pm	1σ
A-5	-0.17	\pm	0.06
C-1	-0.41	\pm	0.06
D-1	-0.43	\pm	0.06
F-4	-0.45	\pm	0.06

^a J. J. Duderstadt and L. J. Hamilton, *Nuclear Reactor Analysis*, John Wiley & Sons, Ann Arbor, Michigan (1976).

2.4.7 Dry Tube Worth

Control rod positions and worths were not available for the measurement of the experiment dry tube worth. The adjusted worth, including a 10 % uncertainty in the measurement and 5 % uncertainty in β_{eff} is $-\$0.06 \pm 0.01$ (1σ).

2.4.8 Summary of Reactivity Effects Measurements

As seen in Sections 1.4 and 2.4, numerous measurements were performed to experimentally measure the worth of various core components in both the 56- and 60-fuel-element cores. Whereas the purpose of the measurements was to obtain specific core parameters, only the desired parameters were evaluated as benchmark experiment measurements. The evaluated worths to be utilized as benchmark measurements include six control rod worths, two shutdown margins, two core excess reactivities, four graphite reflector block worths, and the worth of the experiment dry tube; these reactivity effects are summarized in Table 2.73.

Table 2.73. Select Reactivity Effects Measurements.

Case #	Core Description	Measurement	Worth		
			$\rho\$\$	\pm	1σ
1	56 Fuel Elements	Shim 1 Worth	-2.76	\pm	0.31
2	56 Fuel Elements	Shim 2 Worth	-2.72	\pm	0.30
3	56 Fuel Elements	Reg Worth	-2.43	\pm	0.23
4	60 Fuel Elements	Shim 1 Worth	-2.68	\pm	0.30
5	60 Fuel Elements	Shim 2 Worth	-2.75	\pm	0.33
6	60 Fuel Elements	Reg Worth	-2.42	\pm	0.16
7	56 Fuel Elements	Shutdown Margin	-7.54	\pm	0.49
8	60 Fuel Elements	Shutdown Margin	-6.73	\pm	0.47
9	56 Fuel Elements	Excess Reactivity	0.37	\pm	0.02
10	60 Fuel Elements	Excess Reactivity	1.12	\pm	0.05
11	60 Fuel Elements	Block A-5 Worth	-0.17	\pm	0.06
12	60 Fuel Elements	Block C-1 Worth	-0.41	\pm	0.06
13	60 Fuel Elements	Block D-1 Worth	-0.43	\pm	0.06
14	60 Fuel Elements	Block F-4 Worth	-0.45	\pm	0.06
15	60 Fuel Elements	Dry Tube Worth	-0.06	\pm	0.01

2.5 Evaluation of Reactivity Coefficient Data

Reactivity coefficient measurements have not been evaluated.

2.6 Evaluation of Kinetics Measurements Data

Kinetics measurements were not made.

2.7 Evaluation of Reaction-Rate Distributions

Reaction-rate distribution measurements were not made.

2.8 Evaluation of Power Distribution Data

Power distribution measurements were not made.

2.9 Evaluation of Isotopic Measurements

Isotopic measurements were not made.

2.10 Evaluation of Other Miscellaneous Types of Measurements

Other miscellaneous types of measurements were not made.

3.0 BENCHMARK SPECIFICATIONS

3.1 Benchmark-Model Specifications for Critical and / or Subcritical Measurements

The 60-fuel-element operational core configuration of the NRAD reactor has been evaluated as a benchmark experiment. The initial core critical configuration created during fuel loading, which contains 56 fuel elements, has also been evaluated; it is very similar to the operational core configuration. Besides having four less fuel elements and a different regulating rod position, the graphite block in position A-5 in the 60-fuel-element core is located in position B-5 in the 56-fuel-element core (see Figure 3.8). The 56- and 60-fuel-element configurations will be noted as Cases 1 and 2, respectively.

Additional critical configurations were recorded during the start-up measurements; the initial critical configuration for the 56-fuel-element core with additional detectors, a second critical configuration for the 60-fuel-element operational core with the regulating rod fully withdrawn and the shim rods partially inserted, four configurations with one of the graphite reflector blocks removed from the core, and multiple critical positions for both core configurations during the positive period measurements (see Section 1.4). These configurations are considered very similar to the benchmark experiment configurations and were not evaluated as criticality experiment benchmarks but used to evaluate worth measurements (see Section 3.4).

3.1.1 Description of the Benchmark Model Simplifications

Detailed models (see Appendix C) of the NRAD reactor core configurations were prepared to evaluate biases in the benchmark models. Because the effects of many of the model simplifications produced small or otherwise negligible biases in the benchmark models, a description of detailed benchmark models was unnecessary. Many of the detailed model components, such as assembly fittings, grid plate, and support structures, were homogenized in the detailed model to facilitate computational analyses. Removal of these homogenized components from the model produced negligible bias effects; detailed analysis regarding homogenization effects, biases, and their associated uncertainties was judged to be unnecessary.

3.1.1.1 Evaluation of Benchmark Model Biases

The 60-fuel-element core configuration (Case 2) was used to perform a comprehensive analysis of the model biases as the 56-fuel-element core configuration (Case 1) was not initially evaluated. This benchmark report was later revised to include the 56-fuel-element core. Only a total simplification bias was computed for Case 1 as the individual biases are expected to be similar to those evaluated for Case 2.

Various simplifications were individually evaluated to determine their effective contribution as a model bias to the Case 2 benchmark model. A summary of evaluated biases is listed in Table 3.1. The effective bias for the reduction in tank water moderator thickness surrounding the core both radially (Figure 3.1) and axially (Figure 3.2) was also evaluated for Case 2.

Figure 3.1 shows the bias in reducing the effective radial reflector boundary. A tank water diameter ≥ 90 cm is sufficient for modeling the reactor without incurring any additional bias. The uncertainty is negligible as it is the statistical uncertainty in the MCNP calculations. Figure 3.2 shows the bias in reducing the effective axial reflector thickness as a function of top and bottom reflector thickness with respect to the bottom surface of the bottom axial graphite reflector in the fuel elements and the top surface of the top axial graphite reflector. The effective bias is negligible as all calculations are approximately within the statistical noise. An axial distance of approximately 25 cm from these two surfaces is selected for the benchmark model. Because the NRAD reactor core is contained within a large quantity of reflecting material, room return calculations were unnecessary.

Some possible benchmark biases were evaluated as uncertainties due to a lack of information. They include the following: water saturation of graphite (Section 2.1.6.1), impurities in the tank water (2.1.9), and impurities in the boron carbide absorber (Section 2.1.4.1).

The AmBe source remains in the reactor core during operations. It emits neutrons at the rate of $\sim 1 \times 10^7$ neutrons/sec. The fission rate in the core at 50 W is $\sim 1 \times 10^{12}$ neutrons/sec. Because there are five orders of magnitude difference between the total fission rate and the AmBe source strength, the contribution of the AmBe source neutrons to the total neutron population is judged to be negligible and no additional bias or uncertainty was evaluated.

Evaluated biases with an absolute value ≤ 0.00010 , the 1σ statistical MCNP uncertainty, are considered negligible. Biases with absolute values > 0.00010 and ≤ 0.00030 (3σ) are considered negligible as a bias but treated instead as additional simplification uncertainty. Biases > 0.00030 are treated as a bias with an uncertainty equivalent to one-third of the magnitude of the calculated bias.

Detailed discussion of the evaluated biases are as follows:

- Full Model
 1. All locations in the core (fuel elements and beam lines) containing air were replaced with void.
 2. All locations in the core (control rods, assembly attachments, core structure, beam lines, etc.) containing aluminum (1100, 2011, or 6061) had all non-aluminum elements replaced with void.
- Fuel Assemblies
 3. All lower fuel assembly adapters were replaced with water.
 4. All upper fuel assembly adapters were replaced with water.
 5. All bottom fuel end fittings protruding from the fuel clad were replaced with water.
 6. All top fuel end fittings protruding from the fuel clad were replaced with water.
 7. The impurities in all stainless steel fuel clad and end fittings were replaced with void.
 8. Individual fuel compositions were replaced with an average fuel composition for the core.
 9. The impurities in all axial graphite reflectors were replaced with void.
 10. The impurities in all molybdenum poison discs were replaced with void.
 11. The impurities in all zirconium rods were replaced with void.
- Control Rods
 12. All control rod extension rods and associated attachments were replaced with water.
 13. All control rod guide tubes, and the guide tube in the empty irradiation position, were replaced with water.
 14. All internal aluminum parts in the control rods were replaced with void.
- Graphite Reflector Block Assemblies
 15. All lower graphite assembly adapters were replaced with water.
 16. All upper graphite assembly adapters were replaced with water.
 17. Tie rods, dowels, and screws (Al-2011 parts) in the graphite reflector blocks
 - A. All Al-2011 parts external to the graphite blocks were replaced with water.
 - B. All Al-2011 parts internal to the graphite blocks, and their affiliated orifices, were replaced with graphite block material.
 18. AmBe source, source tube, and source tube cap
 - A. The AmBe source and its affiliated hardware external to the graphite block are replaced with water.
 - B. The AmBe source and its affiliated hardware internal to the graphite block, and the affiliated orifice, were replaced with graphite block material.
 19. All impurities in the graphite block reflectors were replaced with void.
- Core/Tank Structure
 20. The core grid plate was replaced with water.
 21. The core grid support structure was replaced with water.

22. The mounting pad was replaced with water.
23. The reactor tank was replaced with water.
- Neutron Beam Lines
 24. All helium in the beam lines was replaced with void.
 25. All boron nitride apertures were replaced with void.
 26. All beam line supports in the core were replaced with water.
 27. Beam line aluminum structure
 - A. All beam line aluminum structural material was replaced with void.
 - B. All beam line aluminum structural materials, excluding the beam filter tubes, were replaced with void.
 - C. The aluminum structural material of both beam filter tubes was replaced with void.
- Comprehensive Benchmark Simplification
 28. The simplifications outlined in Table 3.1 were applied to the benchmark models. The effective tank water boundary was also reduced radially and axially. The diameter of the tank water in the benchmark model is 90 cm and the effective water height above and below the axial graphite reflectors in the fuel elements is 25 cm.
 - A. The effective bias for incorporating all of these simplifications into the benchmark model for Case 1 was calculated to be 0.00141 ± 0.00010 .
 - B. The effective bias for incorporating all of these simplifications into the benchmark model for Case 2 was calculated to be 0.00095 ± 0.00010 .

Individual biases may be positive or negative and many are comparable to the statistical uncertainties. Correlating effects in bias analysis simplifications may also contribute to the difference between the summation of the individual biases and the bias calculated for the benchmark model when all simplifications are performed simultaneously. This difference, however, is within the estimated 1σ bias uncertainty. The bias computed with all simplifications included together is the best representative of the true bias. The uncertainty in that bias is obtained from the individual analysis of each simplification.

Table 3.1. Evaluated Benchmark Model Simplification Biases.^(a)

No.	Evaluated Simplifications	Calculated Bias			Benchmark Bias		
		Δk_{eff}	\pm	1σ	Δk_{eff}	\pm	1σ
Full Model							
1	Replace air with void	0.00001	\pm	0.00010	neg		
2	Replace non-aluminum elements in aluminum materials with void	0.00004	\pm	0.00010	neg		
Fuel Assemblies							
3	Replace lower fuel assembly adapters with water	0.00026	\pm	0.00010	\pm 0.00026		
4	Replace upper fuel assembly adapters with water	-0.00007	\pm	0.00010	neg		
5	Replace fuel bottom end fittings (external to cladding) with water	0.00056	\pm	0.00010	0.00056	\pm	0.00019
6	Replace fuel top end fittings (external of cladding) with water	0.00038	\pm	0.00010	0.00038	\pm	0.00013
7	Replace stainless steel clad and end fitting impurities with void	0.00079	\pm	0.00010	0.00079	\pm	0.00026
8	Replace individual fuel compositions with average fuel composition	-0.00061	\pm	0.00010	-0.00061	\pm	0.00020
9	Replace axial graphite reflector impurities with void	0.00006	\pm	0.00010	neg		
10	Replace molybdenum poison disc impurities with void	-0.00001	\pm	0.00010	neg		
11	Replace zirconium rod impurities with void	0.00006	\pm	0.00010	neg		
Control Rods							
12	Replace control rod extension rods and attachments with water	0.00000	\pm	0.00010	neg		
13	Replace guide tubes with water	0.00148	\pm	0.00010	0.00148	\pm	0.00049
14	Replace internal fittings within control rods with void	0.00011	\pm	0.00010	\pm 0.00011		
Graphite Reflector Block Assemblies							
15	Replace lower graphite assembly adapters with water	-0.00005	\pm	0.00010	neg		
16	Replace upper graphite assembly adapters with water	0.00016	\pm	0.00010	\pm 0.00016		
17A	Replace graphite assembly Al-2011 parts with water	0.00014	\pm	0.00010	\pm 0.00014		
17B	Replace graphite assembly Al-2011 parts and holes with graphite	-0.00001	\pm	0.000010	neg		
18A	Replace AmBe source and steel source tube with water	0.00024	\pm	0.00010	\pm 0.00024		
18B	Replace AmBe graphite reflector block with normal block	0.00026	\pm	0.00010	\pm 0.00026		
19	Replace graphite reflector block impurities with void	-0.00004	\pm	0.00010	neg		

Table 3.1 (cont'd.). Evaluated Benchmark Model Simplification Biases.

No.	Evaluated Simplifications	Calculated Bias		Benchmark Bias	
		Δk_{eff}	$\pm 1\sigma$	Δk_{eff}	$\pm 1\sigma$
Core/Tank Structure					
20	Replace grid plate with water	0.00008	± 0.00010	neg	
21	Replace grid support structure with water	-0.00008	± 0.00010	neg	
22	Replace mounting pad with water	0.00000	± 0.00010	neg	
23	Replace reactor tank with water	-0.00015	± 0.00010		± 0.00015
Neutron Beam Lines					
24	Replace helium with void	0.00014	± 0.00010		± 0.00014
25	Replace boron nitride apertures with void	-0.00010	± 0.00010	neg	
26	Replace beam line supports with water	-0.00020	± 0.00010		± 0.00020
27A	Replace beam line aluminum structure with void	-0.00085	± 0.00010	-0.00085	± 0.00028
27B	Replace beam line aluminum (excluding beam filter tube) with void	-0.00008	± 0.00010	--	
27C	Replace beam filter tube aluminum with void	-0.00070	± 0.00010	--	
--	Summation of Individual Biases ^(a)	--		0.00175	± 0.00090
28	Complete Benchmark Model Simplification (Case 1)^(b)	0.00141	± 0.00010	0.00141	\pm 0.00090
	Complete Benchmark Model Simplification (Case 2)	0.00095	± 0.00010	0.00095	\pm 0.00090

(a) Individual bias simplifications were only evaluated for Case 2.

(b) The evaluated bias uncertainty for Case 2 was also applied as the bias uncertainty for Case 1.

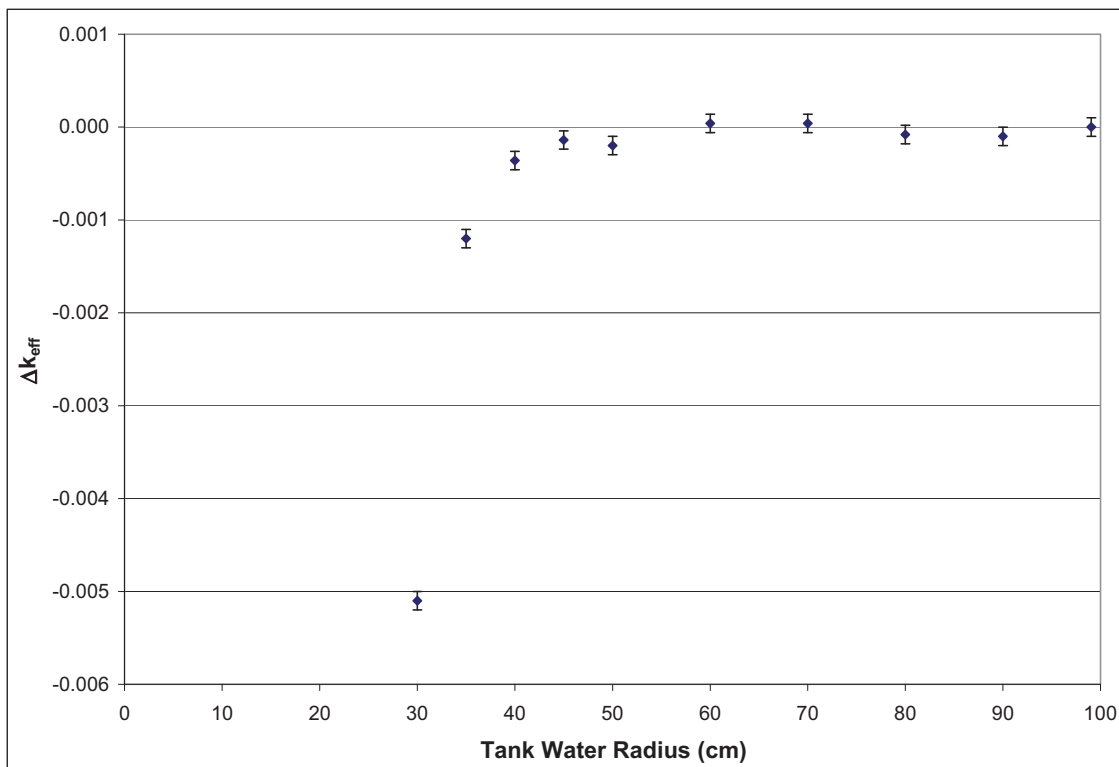

Figure 3.1. Effective Bias Due to Tank Water Radial Boundary (Case 2).

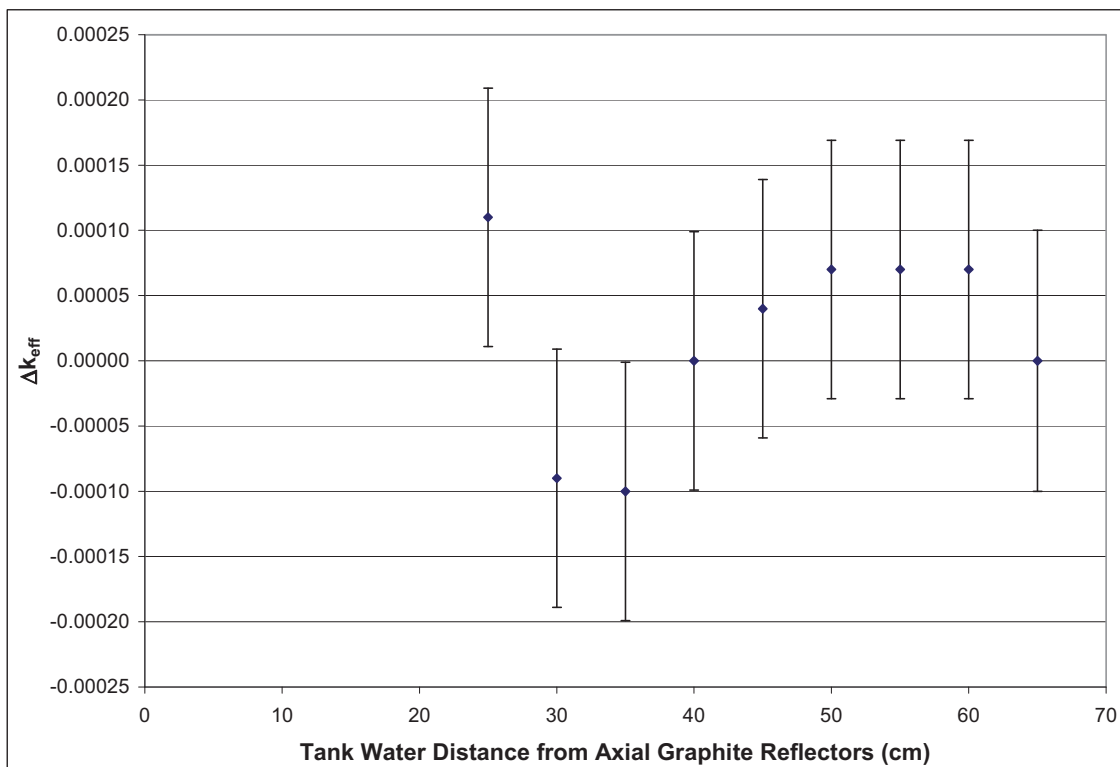

Figure 3.2. Effective Bias Due to Tank Water Axial Boundary (Case 2).

3.1.2 Dimensions

The NRAD reactor is a square-pitched TRIGA conversion reactor with various assemblies. The primary assemblies are four-fuel-element clusters and graphite reflector blocks. A three-fuel-element cluster assembly replaces the empty fuel position with either a control rod or water. Empty core positions contain water and two void regions extend from the core on the East and North ends, representative of beam lines used in neutron radiography experiments.

3.1.2.1 Graphite Reflector Block

The graphite reflector block assembly consists of high purity graphite with overall block dimensions shown in Figure 3.3.

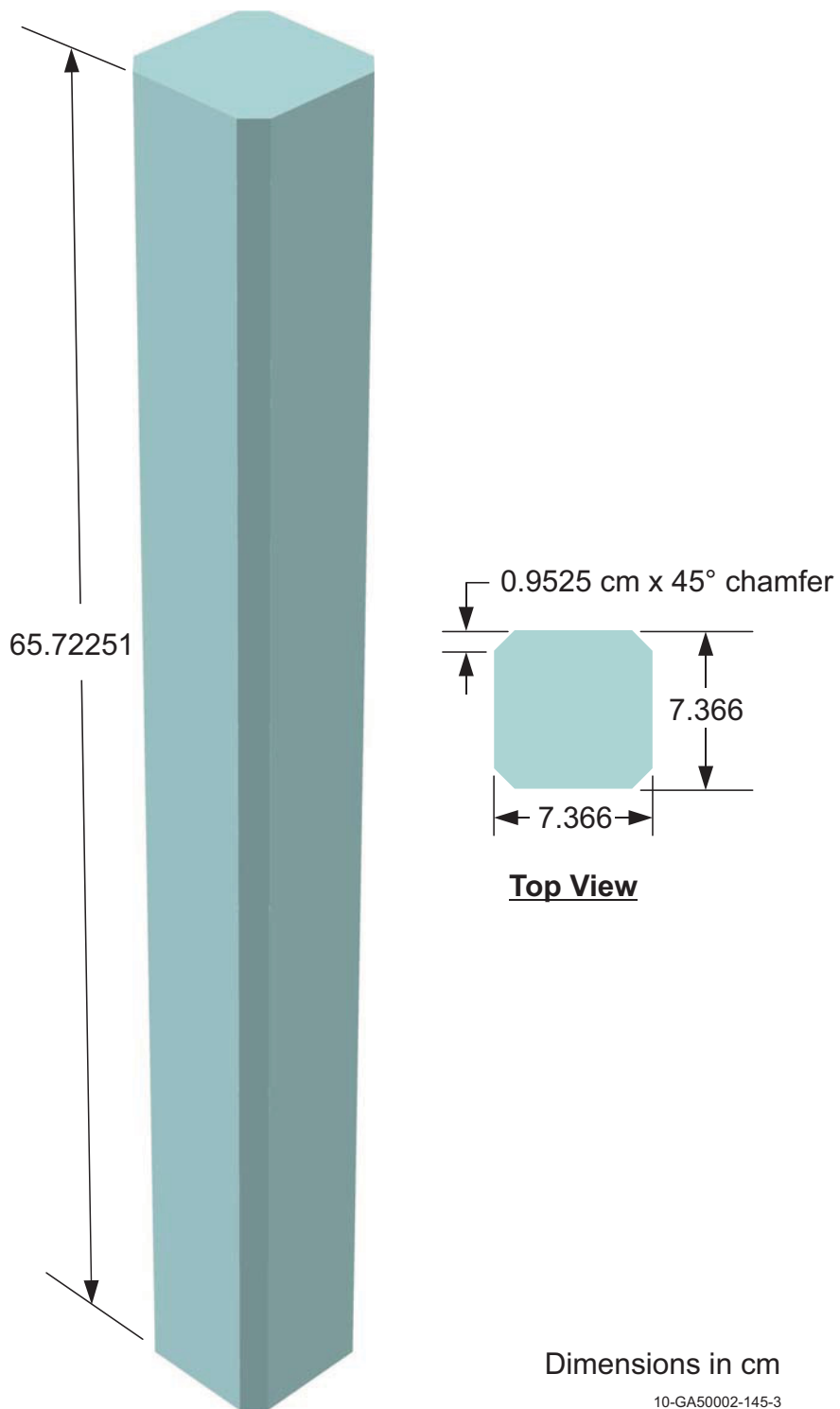

Figure 3.3. Graphite Reflector Block.

3.1.2.2 Fuel Element

The TRIGA fuel element (Figure 3.4) consists of uranium-erbium-zirconium-hydride fuel with axial high-purity graphite reflectors above and below the fuel. A thin molybdenum poison disc is located between the fuel and the bottom axial reflector. A zirconium rod is located coaxially within the fuel meat. The components are contained within stainless steel cladding with end fixtures. The regions surrounding the fuel element components and within the steel cladding is void.

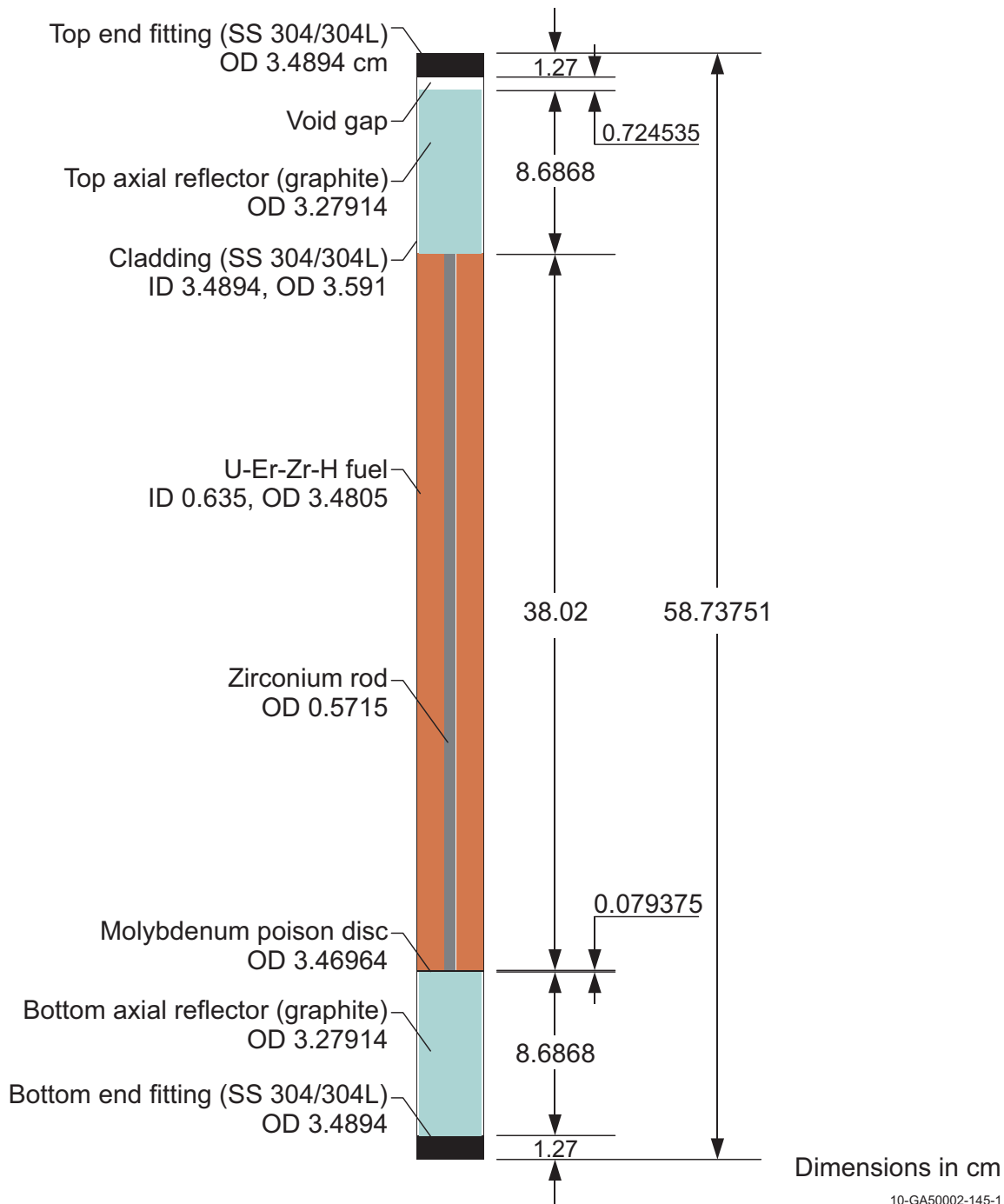

Figure 3.4. TRIGA Fuel Element.

3.1.2.3 Control Rod

The TRIGA control rod (Figure 3.5) consists of a boron carbide, B_4C , absorber rod contained within aluminum cladding with end fixtures. The region surrounding the absorber rod and within the aluminum cladding is void.

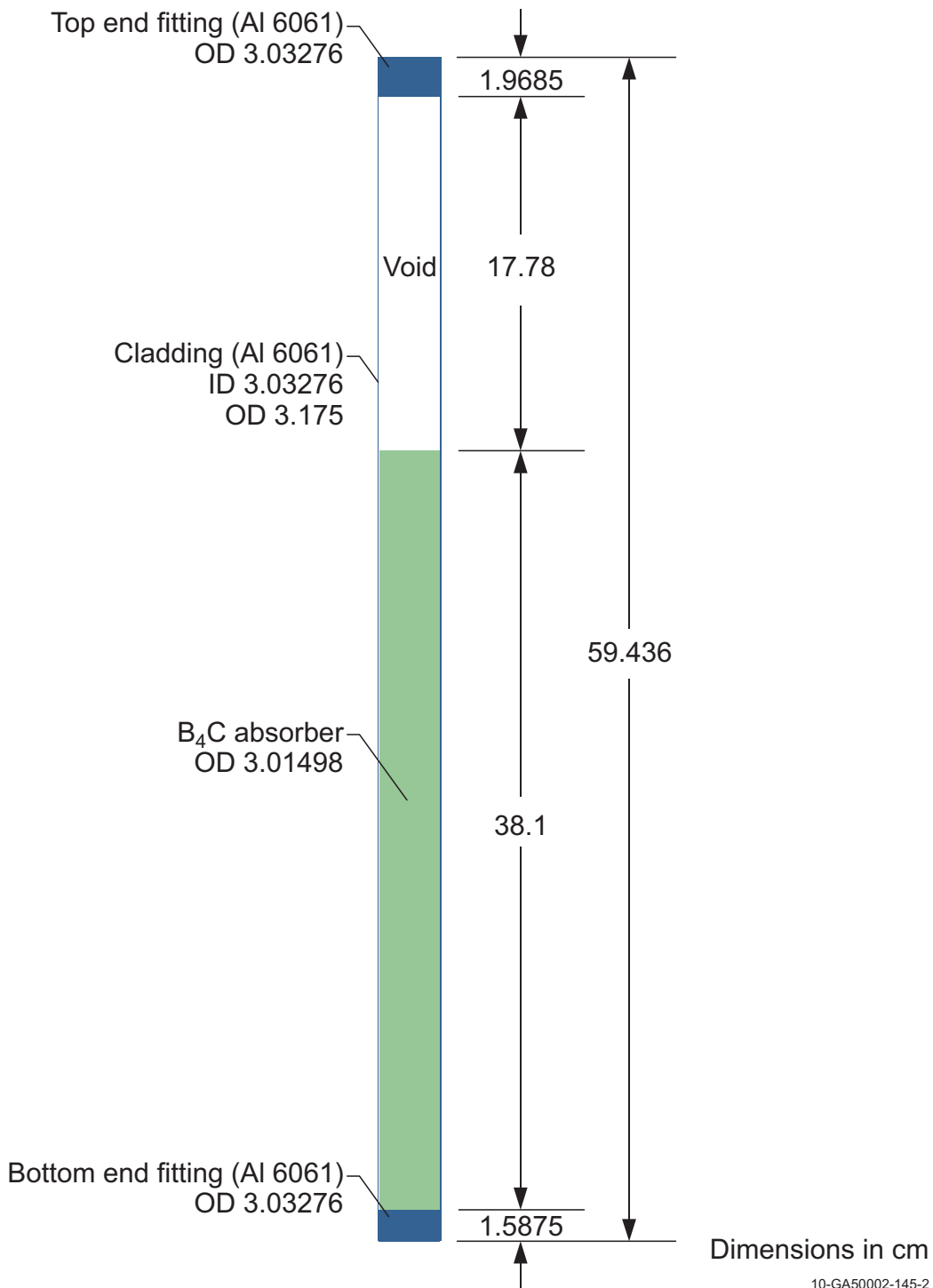

Figure 3.5. TRIGA Control Rod.

3.1.2.4 Four-Element Fuel Cluster

A four-element fuel cluster assembly consists of four fuel elements, as described in Section 3.1.2.2, placed in the configuration shown in Figure 3.6.

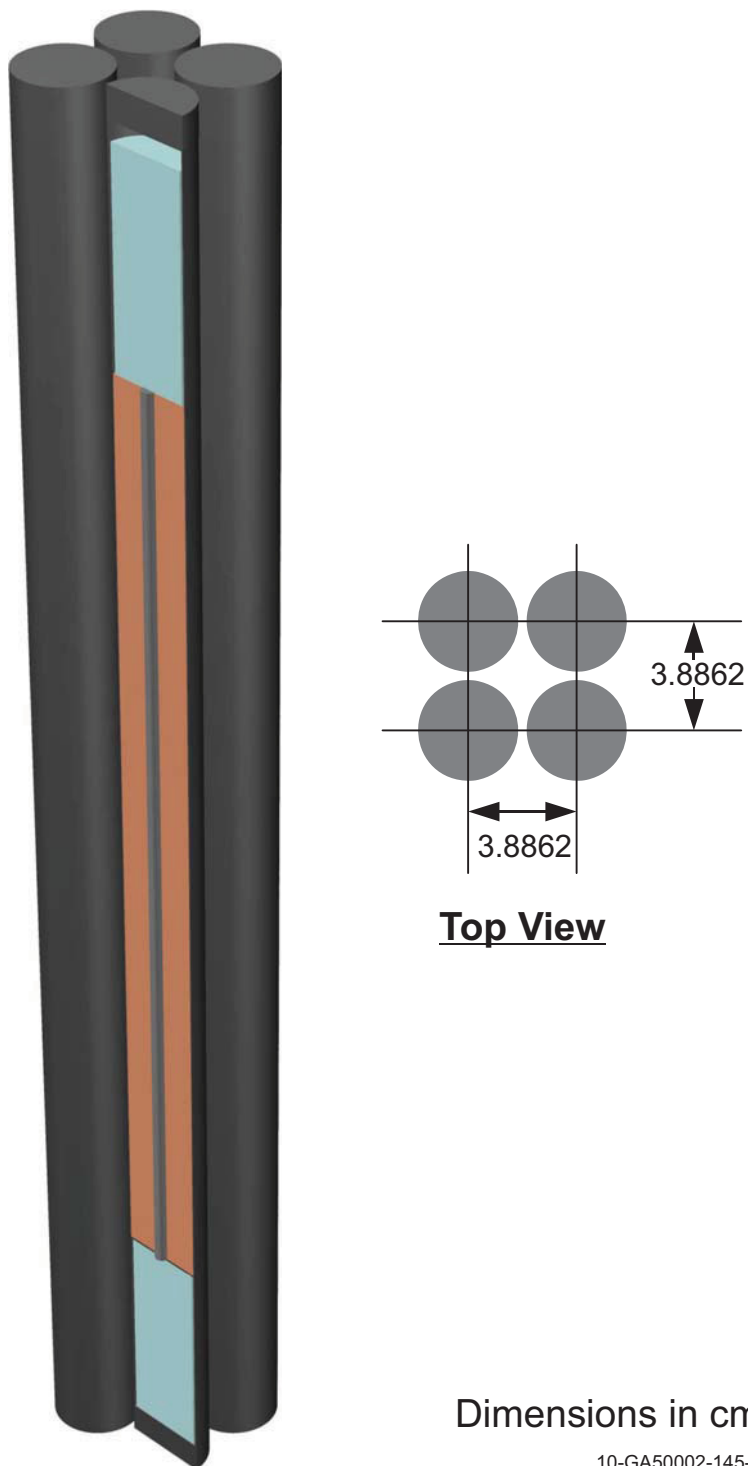

Figure 3.6. Four-Element Fuel Cluster.

3.1.2.5 Three-Element Fuel Cluster

A three-element fuel cluster is identical in configuration to the four-element fuel cluster described in Section 3.1.2.4. However, one of the fuel elements is removed and replaced by either a control rod or water (experiment irradiation position). For the locations of three-element fuel clusters in the NRAD reactor core, see Figure 3.8.

3.1.2.6 Assembly Pitch

The pitch between assemblies, whether graphite reflector blocks, four-element fuel clusters, or three-element fuel clusters, is shown in Figure 3.7. The pitch is shorter in the North-South direction than in the East-West direction.

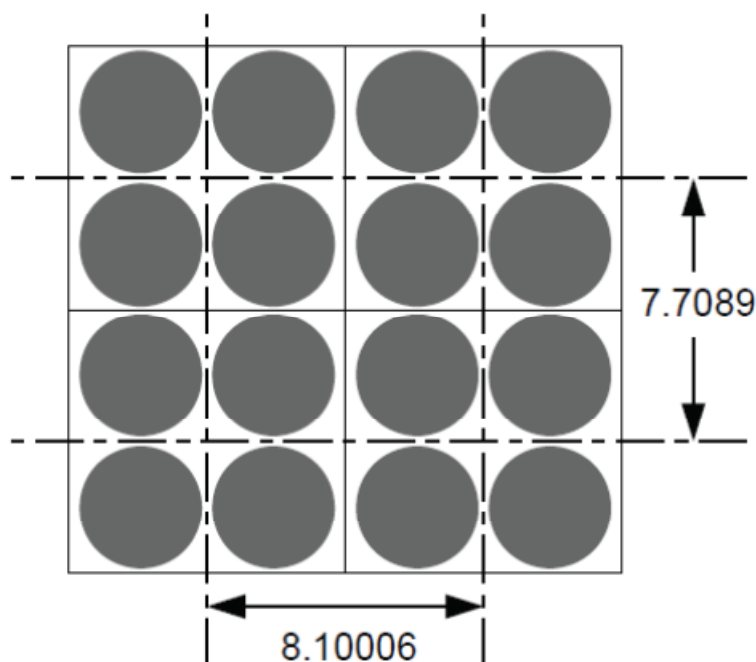

Dimensions in cm

10-GA50002-145-5

Figure 3.7. NRAD Core Assembly Pitch.

3.1.2.7 Core Configuration

The NRAD reactor core configurations are shown in Figures 3.8 and 3.9. The cores contain three control rods (two shims and a regulating rod), 12 graphite reflector blocks, one empty fuel position, and four empty assembly positions. Cases 1 and 2 have 56 and 60 fuel elements, respectively (see Figures 3.8a and 3.8b, respectively). Beam lines extend from the East and North faces of the core (Figure 3.10) and are centered along the core fuel midplane. The beams are represented as voids in the benchmark model and extend to the model radial boundary. All model locations not containing fuel elements, control rods, graphite, or void, as previously described in this section, contain water. A comparison of the vertical placement of different reactor components is shown in Figure 3.11.

The shim 1, shim 2, and regulating control rods are withdrawn 38.1, 38.1, and 29.5275 cm, respectively (use Figure 3.8 for placement in the core and Figure 3.11 for reference vertical placement), for Case 1.

The shim 1, shim 2, and regulating control rods are withdrawn 38.1, 38.1, and 20.4216 cm, respectively (use Figure 3.8 for placement in the core and Figure 3.11 for reference vertical placement), for Case 2.

The measurement of 2.032 cm in Figures 3.9 and 3.10 represents the distance between the outer cladding surface of the fuel elements closest to the beam filter tube and the face of the beam filter tube adjacent to the core.

The measurement of 0.123825 cm in Figure 3.11 represents the difference between the bottom of the fuel meat (top of the molybdenum poison disc) in the fuel elements and the bottom of the control rod absorber material when the control rod is fully inserted into the core. The bottom of the fully-inserted control rod absorber material is positioned slightly above the bottom of the fuel meat.

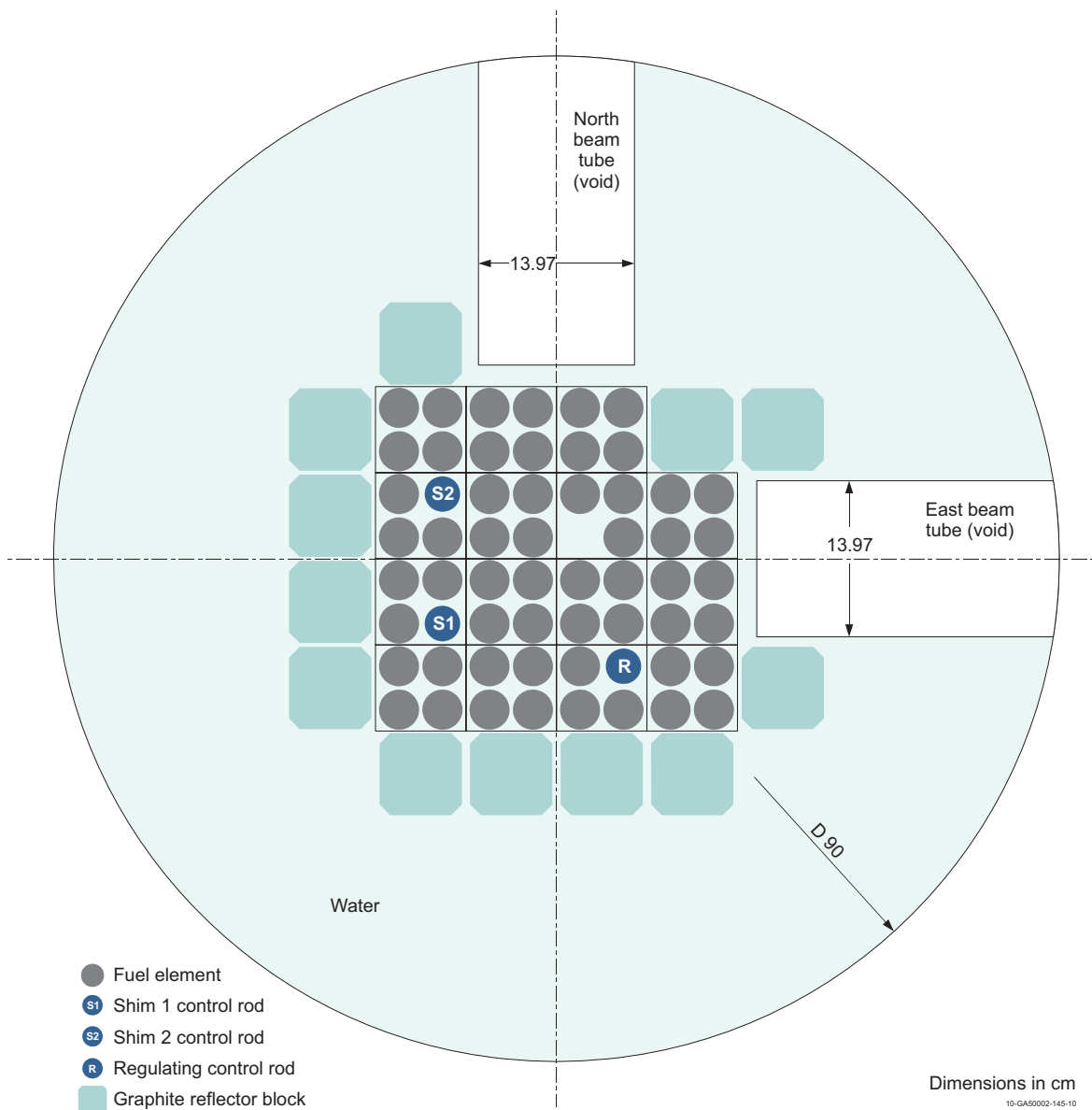

Figure 3.8a. Midplane Cross Section View of NRAD Reactor Core (Case 1).

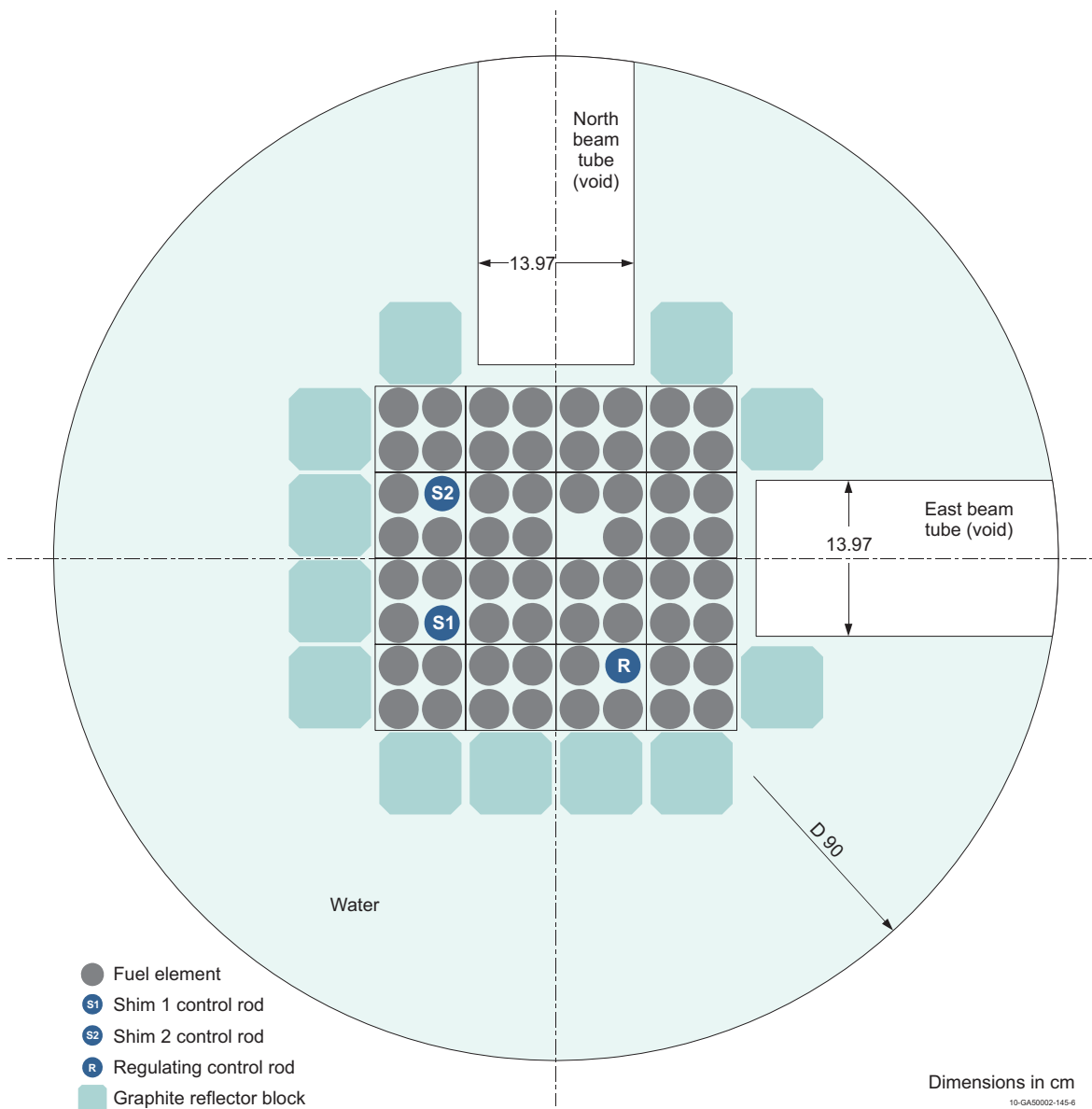

Figure 3.8b. Midplane Cross Section View of NRAD Reactor Core (Case 2).

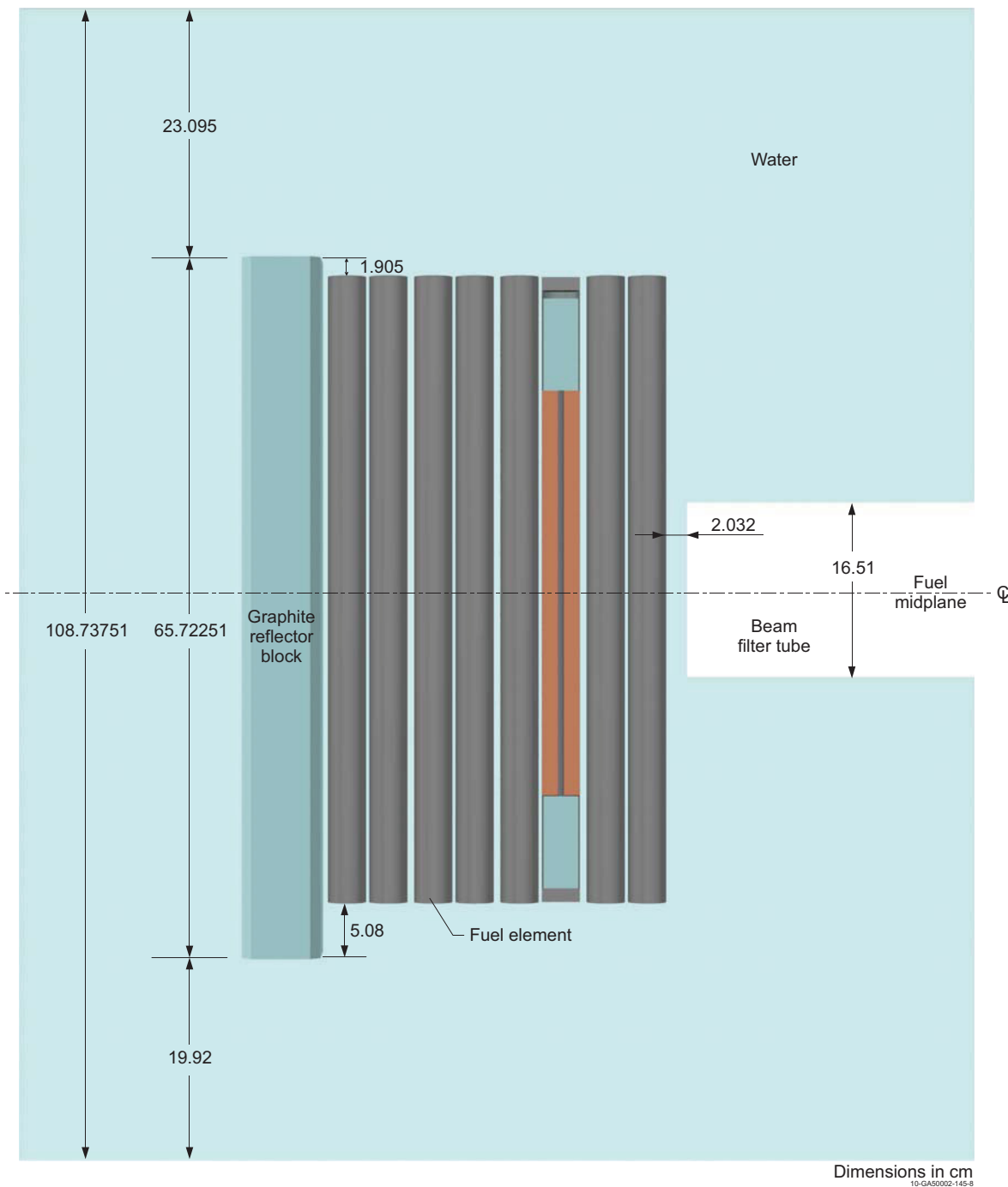
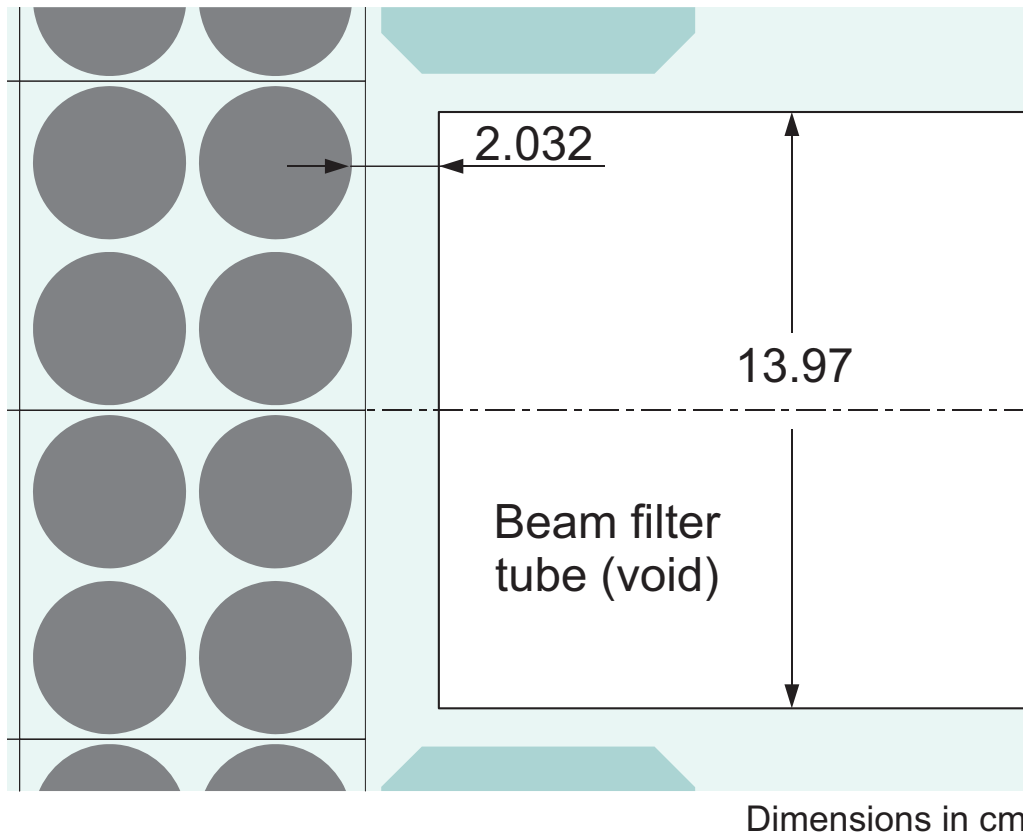

Figure 3.9. Vertical Cross Section View of NRAD Reactor Core through the Centerline of the Fuel Elements Located in the North Half of the Third Row (from the Top) of Fueled Assemblies.



10-GA50002-145-7

Figure 3.10. Beam Filter Tube Placement.

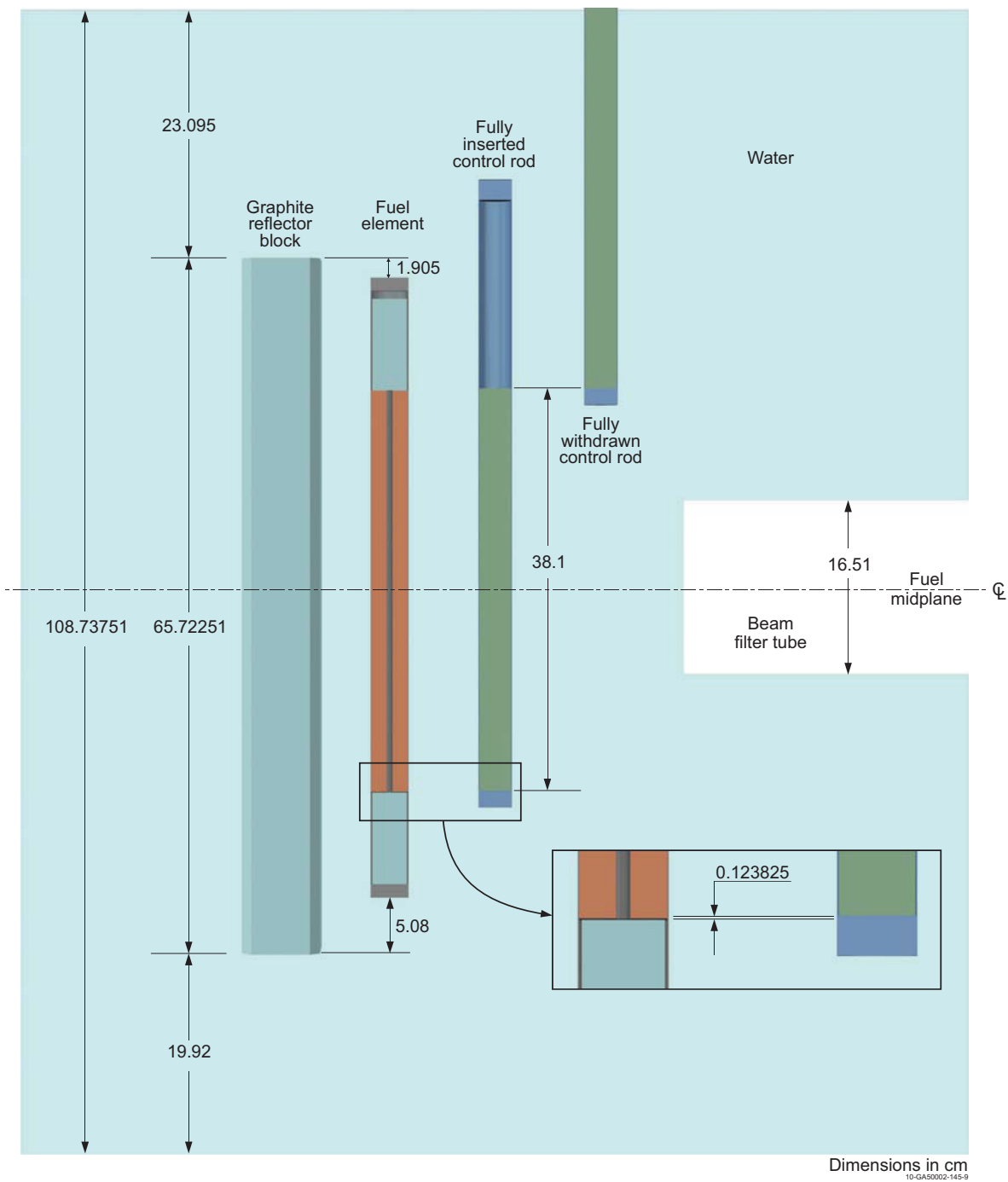

Figure 3.11. NRAD Reactor Core Reference Vertical Placement.

3.1.3 Material Data**3.1.3.1 Graphite Reflector Block**

The graphite reflector block consists of high purity graphite with a mass density of 1.570 g/cm³. Impurities in the graphite have been removed from the benchmark model (Section 2.1.6.1 and 3.1.1.1). The atomic density and composition of the graphite are shown in Table 3.2.

Table 3.2. Graphite Reflector Block Density.

Isotope/Element	Composition (wt.%)	Atoms/barn-cm
C	99.968029	7.8692E-02
Total	99.968029 ^(a)	7.8692E-02

(a) Total weight fraction has been reduced due to the removal of material impurities.

3.1.3.2 Uranium-Erbium-Zirconium-Hydride Fuel

The uranium-erbium-zirconium-hydride fuel has a mass density of 7.167492 and 7.167778 g/cm³ for Cases 1 and 2, respectively. Evaluation of the average fuel composition for use in benchmark model is discussed in Section 2.1.2. The atomic density and composition of the fuel are shown in Table 3.3.

Table 3.3a. Uranium-Erbium-Zirconium-Hydride Fuel Atomic Density (Case 1).

Isotope/Element	Composition (wt.%)	Atoms/barn-cm
H	1.182010	5.0620E-02
B	0.000096	3.8328E-07
C	0.3	1.0781E-03
Zr	67.707044	3.2036E-02
Er	0.9	2.3226E-04
Hf	0.003413	8.2525E-07
²³⁴ U	0.053833	9.9283E-06
²³⁵ U	5.900894	1.0836E-03
²³⁶ U	0.065796	1.2032E-05
²³⁸ U	23.886914	4.3312E-03
Total	100.0	8.9404E-02

Table 3.3b. Uranium-Erbium-Zirconium-Hydride Fuel Atomic Density (Case 2).

Isotope/Element	Composition (wt.%)	Atoms/barn-cm
H	1.181825	5.0614E-02
B	0.000096	3.8330E-07
C	0.3	1.0781E-03
Zr	67.696454	3.2032E-02
Er	0.9	2.3226E-04
Hf	0.003412	8.2516E-07
²³⁴ U	0.053853	9.9323E-06
²³⁵ U	5.904648	1.0844E-03
²³⁶ U	0.065820	1.2036E-05
²³⁸ U	23.893892	4.3326E-03
Total	100.0	8.9397E-02

3.1.3.3 Axial Graphite Reflector

The axial graphite reflector consists of high purity graphite with a mass density of 1.73 g/cm³. Impurities in the graphite have been removed from the benchmark model (Section 2.1.3.3 and 3.1.1.1). The atomic density and composition of the graphite are shown in Table 3.4.

Table 3.4. Axial Graphite Reflector Atomic Density.

Isotope/Element	Composition (wt.%)	Atoms/barn-cm
C	99.994614	8.6734E-02
Total	99.994614 ^(a)	8.6734E-02

(a) Total weight fraction has been reduced due to the removal of material impurities.

3.1.3.4 Molybdenum Poison Disc

The molybdenum poison disc has a mass density of 10.22 g/cm³. Impurities in the molybdenum have been removed from the benchmark model (Section 2.1.3.2 and 3.1.1.1). The atomic density and composition of the molybdenum are shown in Table 3.5.

Table 3.5. Molybdenum Poison Disc Atomic Density.

Isotope/Element	Composition (wt.%)	Atoms/barn-cm
Mo	99.968464	6.4130E-02
Total	99.968464 ^(a)	6.4130E-02

(a) Total weight fraction has been reduced due to the removal of material impurities.

3.1.3.5 Zirconium Rod

The zirconium rod has a mass density of 6.51 g/cm³. Impurities in the zirconium have been removed from the benchmark model (Section 2.1.3.1 and 3.1.1.1). The atomic density and composition of the zirconium are shown in Table 3.6.

Table 3.6. Zirconium Rod Atomic Density.

Isotope/Element	Composition (wt.%)	Atoms/barn-cm
Zr	91.817	4.2897E-02
Total	91.817 ^(a)	4.2897E-02

(a) Total weight fraction has been reduced due to the removal of material impurities.

3.1.3.6 Stainless Steel

The stainless steel 304/304L cladding and end fittings have a mass density of 8.00 g/cm³. Impurities in the stainless steel have been removed from the benchmark model (Section 2.1.3.4 and 3.1.1.1). The atomic density and composition of the stainless steel are shown in Table 3.7.

Table 3.7. Stainless Steel Atomic Density.

Isotope/Element	Composition (wt.%)	Atoms/barn-cm
C	0.04	1.6044E-04
Si	0.4	6.8614E-04
P	0.026	4.0441E-05
S	0.0022	3.3049E-06
Cr	19	1.7604E-02
Mn	1	8.7693E-04
Fe	68.70712775	5.9271E-02
Ni	10	8.2087E-03
Total	99.17532775 ^(a)	8.6851E-02

(a) Total weight fraction has been reduced due to the removal of material impurities.

3.1.3.7 Boron Carbide Absorber

The boron carbide absorber has a mass density of 2.48 g/cm³. The atomic density and composition of the boron carbide are shown in Table 3.8.

Table 3.8. Boron Carbide Absorber Atomic Density.

Isotope/Element	Composition (wt.%)	Atoms/barn-cm
¹⁰ B	78.2626	2.1515E-02
¹¹ B		8.6601E-02
C	21.7374	2.7029E-02
Total	100.0000	1.3514E-01

3.1.3.8 Aluminum

The aluminum 6061 cladding and end fittings have a mass density of 2.70 g/cm³. Non-aluminum elements in the aluminum material have been removed from the benchmark model (Section 2.1.4.2 and 3.1.1.1). The atomic density and composition of the aluminum are shown in Table 3.9.

Table 3.9. Aluminum Atomic Density.

Isotope/Element	Composition (wt.%)	Atoms/barn-cm
Al	97.23	5.8593E-02
Total	97.23 ^(a)	5.8593E-02

(a) Total weight fraction has been reduced due to the removal of material impurities.

3.1.3.9 Water

The water has a mass density of 0.9968 and 0.9965 g/cm³ for Cases 1 and 2, respectively. The atomic density and composition of the water are shown in Table 3.10.

Table 3.10a. Water Atomic Density (Case 1).

Isotope/Element	Composition (wt.%)	Atoms/barn-cm
H	11.1894	6.6641E-02
O	88.8106	3.3320E-02
Total	100.0000	9.9961E-02

Table 3.10b. Water Atomic Density (Case 2).

Isotope/Element	Composition (wt.%)	Atoms/barn-cm
H	11.1894	6.6619E-02
O	88.8106	3.3309E-02
Total	100.0000	9.9928E-02

3.1.4 Temperature Data

The benchmark model temperature is 300 K.

3.1.5 Experimental and Benchmark-Model k_{eff} and / or Subcritical Parameters

The experimental k_{eff} values were approximately at unity, made to delayed critical, with respective 1 σ uncertainties as reported in Section 2.1.12 for each configuration. Simplification biases and uncertainties, as discussed in Section 3.1.1.1 were applied to the benchmark models. The benchmark k_{eff} values are shown in Table 3.11 for each case. The uncertainty in the benchmark k_{eff} values is obtained by summing under quadrature the total experimental uncertainty (Tables 2.65 and 2.64 for Cases 1 and 2, respectively) and the estimated bias uncertainty (Table 3.1).

Table 3.11. Experimental and Benchmark Eigenvalues.

Case	# Fuel Elements	Experimental			Bias			Benchmark		
		k_{eff}	\pm	σ	Δk	\pm	σ	k_{eff}	\pm	σ
1	56	1.0000	\pm	0.0028	0.0014	\pm	0.0009	1.0014	\pm	0.0029
2	60	1.0000	\pm	0.0024	0.0010	\pm	0.0009	1.0010	\pm	0.0025

3.2 Benchmark-Model Specifications for Buckling and Extrapolation-Length Measurements

Buckling and extrapolation length measurements were not made.

3.3 Benchmark-Model Specifications for Spectral Characteristics Measurements

Spectral characteristics measurements were not made.

3.4 Benchmark-Model Specifications for Reactivity Effects Measurements

Numerous measurements were performed to experimentally measure the worths of various core components in both the 56- and 60-fuel-element cores (see Sections 1.4 and 2.4). Whereas the purposes of the measurements were to obtain specific core parameters, only the desired parameters were evaluated as benchmark experiment measurements. Reactivity effects measurements evaluated include a total fifteen measurements: six control rod worths (Cases 1 through 6), two shutdown margins (Cases 7 and 8), two core excess reactivities (Cases 9 and 10), four graphite reflector block worths (Cases 11 through 14), and the worth of the experiment dry tube (Case 15), as summarized in Table 2.73.

3.4.1 Description of the Benchmark Model Simplifications

Detailed models (see Appendix C) of the NRAD reactor core configurations were prepared to evaluate biases in the benchmark models. Calculations performed using the benchmark models provided in Section 3.1 with the model simplifications described in Section 3.1.1.1 yielded results similar to, within the statistical uncertainty, results calculated using the detailed models. Therefore, no bias is applied to the benchmark values.

The reactivity effects measurements were reported in units of $\$$ using a β_{eff} value of 0.0071; they will be adjusted for the selected β_{eff} value of 0.0075 for comparison with calculations and for use as benchmark measurements. For further discussion regarding the selection of β_{eff} , please see Section 2.4.1.

As discussed in Section 2.4, control rod worths are sensitive to perturbations in the core flux. Therefore, in order to avoid incurring additional biases and bias uncertainties, the benchmark models are developed to reflect the actual measurement methods used to obtain the experimental data.

3.4.2 Dimensions

The dimensions of the benchmark models for determination of the reactivity effects measurements in the NRAD reactor are identical to those of the critical core configurations described in Section 3.1.2, with exceptions discussed below. The position of the assemblies in the 56- and 60-fuel-element core configurations are shown in Figures 3.8a and 3.8b, respectively.

3.4.2.1 Control Rod Worths

The worth of the shim rods is obtained by comparing the critical configuration of each core with one in which a single shim rod has been fully inserted. A summary of the rod positions is provided in Table 3.12.

The worth of the regulating rod is obtained by first comparing the critical configuration of each core with one in which the regulating rod has been fully inserted to obtain a partial rod worth. Then a series of rod-exchange configurations are performed to obtain the remaining rod worth. The summation of the absolute worth of each pair of rod movements provides the total regulating rod worth. A summary of the rod positions is provided in Table 3.13.

Table 3.12. Control Rod Positions to Determine Shim Rod Worths.

Case #	Core Description	Measurement (Method)	Position #	Shim 1 Position (cm)	Shim 2 Position (cm)	Reg Position (cm)
1	56 Fuel Elements	Shim 1 Worth (Rod Drop)	a1	38.1	38.1	29.5656
			a2	0.0	38.1	29.5656
2	56 Fuel Elements	Shim 2 Worth (Rod Drop)	a1	38.1	38.1	29.5656
			a2	38.1	0.0	29.5656
4	60 Fuel Elements	Shim 1 Worth (Rod Drop)	a1	38.1	38.1	20.4216
			a2	0.0	38.1	20.4216
5	60 Fuel Elements	Shim 2 Worth (Rod Drop)	a1	38.1	38.1	20.4216
			a2	38.1	0.0	20.4216

Table 3.13. Control Rod Positions to Determine Regulating Rod Worths.

Case #	Core Description	Measurement (Method)	Position #	Shim Positions (cm)	Reg Position (cm)
3	56 Fuel Elements	Partial Reg Worth (Rod Drop)	a1	38.1	29.5656
			a2	38.1	0.0
		Partial Reg Worth (Positive Period)	b1	38.1	29.5656
			b2	38.1	31.6992
			c1	35.6616	31.6992
			c2	35.6616	34.4043
			d1	34.0614	34.4043
			d2	34.0614	38.1
6	60 Fuel Elements	Partial Reg Worth (Rod Drop)	a1	38.1	20.4216
			a2	38.1	0.0
		Partial Reg Worth (Positive Period)	b1	38.1	20.4216
			b2	38.1	21.9837
			c1	35.3568	21.9837
			c2	35.3568	23.8125
			d1	33.2994	23.8125
			d2	33.2994	25.6794
			e1	31.6230	25.6794
			e2	31.6230	27.6987
			f1	30.2133	27.6987
			f2	30.2133	30.0228
			g1	28.9941	30.0228
			g2	28.9941	32.5755
			h1	27.9273	32.5755
			h2	27.9273	34.6329
			i1	27.3939	34.6329
			i2	27.3939	38.1

3.4.2.2 Shutdown Margins

The shutdown margin is represented by the worth of the control rods inserted into the core at critical. For both core configurations, this value is obtained by summing the individual worths obtained for the shim rods using the procedure in Table 3.12 and the regulating rod using the partial rod worth obtained using the rod drop method in Table 3.13. Shutdown margins for the 56- and 60-fuel-element cores are labeled as Cases 7 and 8, respectively.

3.4.2.3 Excess Reactivities

The core excess reactivity is represented by the worth of the control rod withdrawn from the core at critical. For both core configurations, this value is obtained by summing the worths obtained for the regulating rod using the positive period method in Table 3.13. Excess reactivities for the 56- and 60-fuel-element cores are labeled as Cases 9 and 10, respectively.

3.4.2.4 Graphite Reflector Block Worths

Four graphite reflector blocks are individually removed from the 60-fuel-element critical configuration (Case 2 in Section 3.1). The removed positions are replaced with water, as shown in Figures 3.12 through 3.15 for positions A-5, C-1, D-1, and F-4 (compare with Figure 3.8b).

The worth of the graphite blocks is obtained by subtracting the excess reactivity obtained for the 60-fuel-element core configuration from the excess reactivity obtained for the respective configurations with the blocks removed from the core. A summary of the rod positions to determine the excess reactivities for these additional configuration variants is provided in Table 3.14.

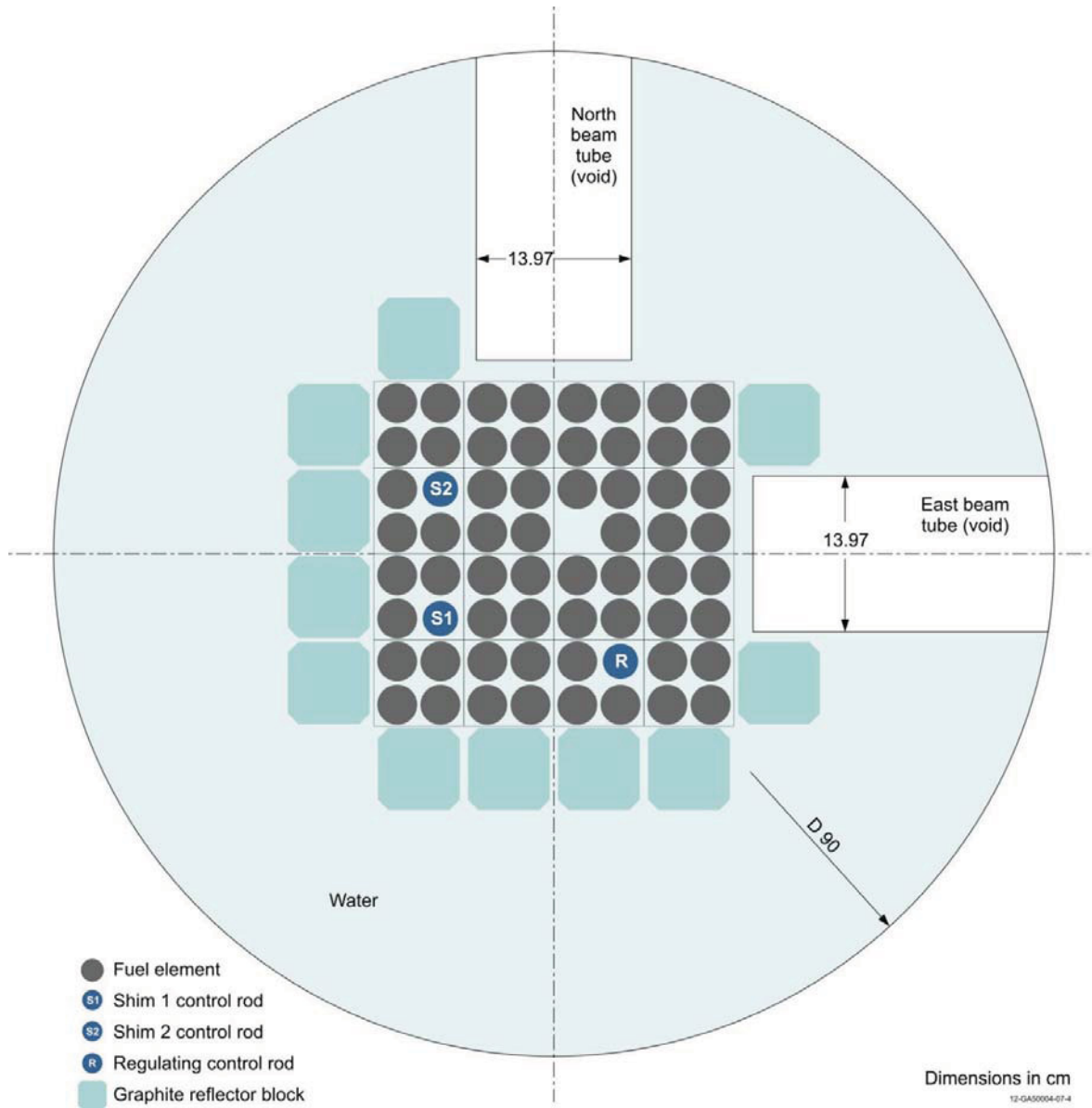

Figure 3.12. Midplane Cross Section View of NRAD Reactor Core without Block in Position A-5.

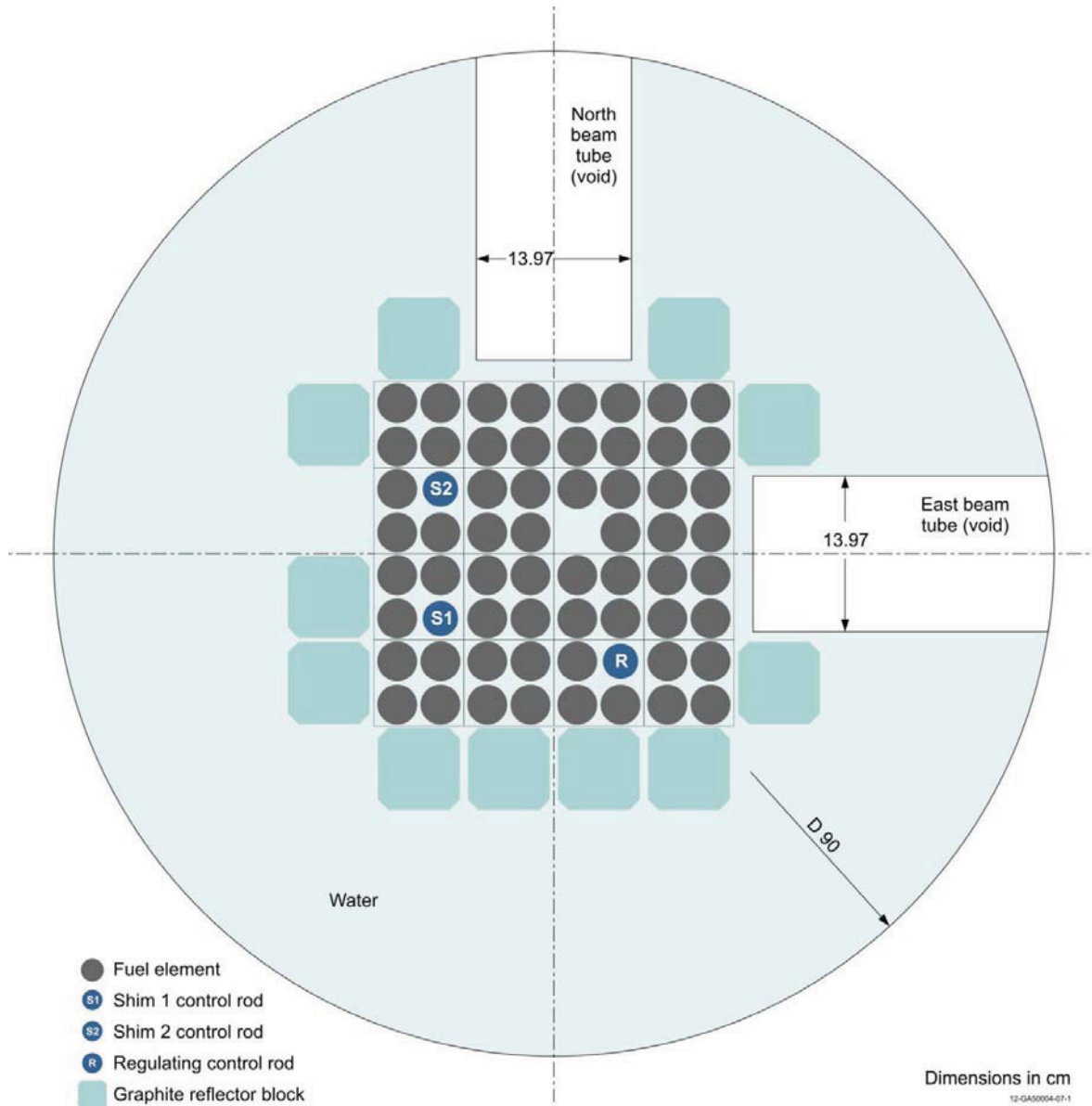

Figure 3.13. Midplane Cross Section View of NRAD Reactor Core without Block in Position C-1.

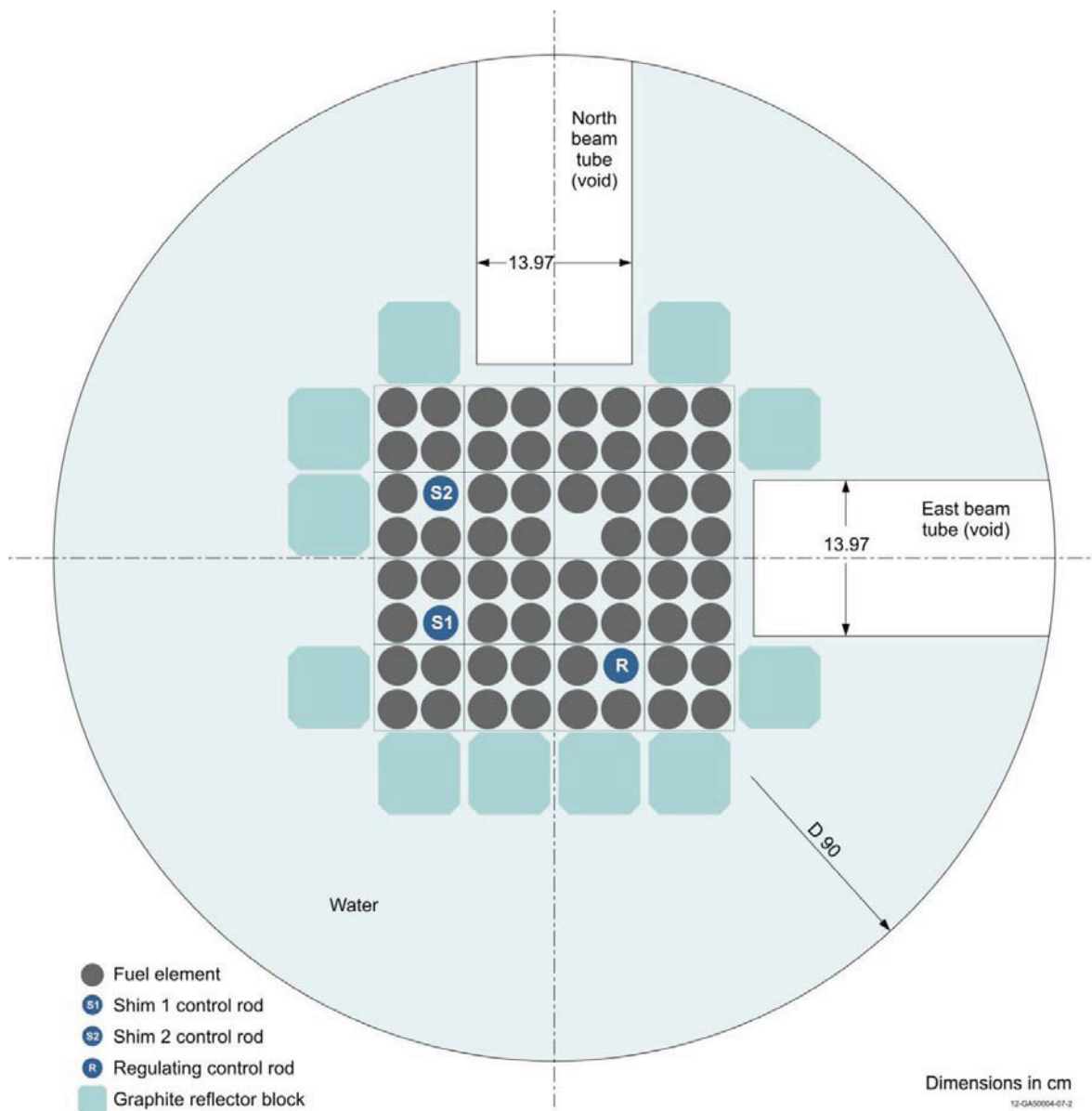

Figure 3.14. Midplane Cross Section View of NRAD Reactor Core without Block in Position D-1.

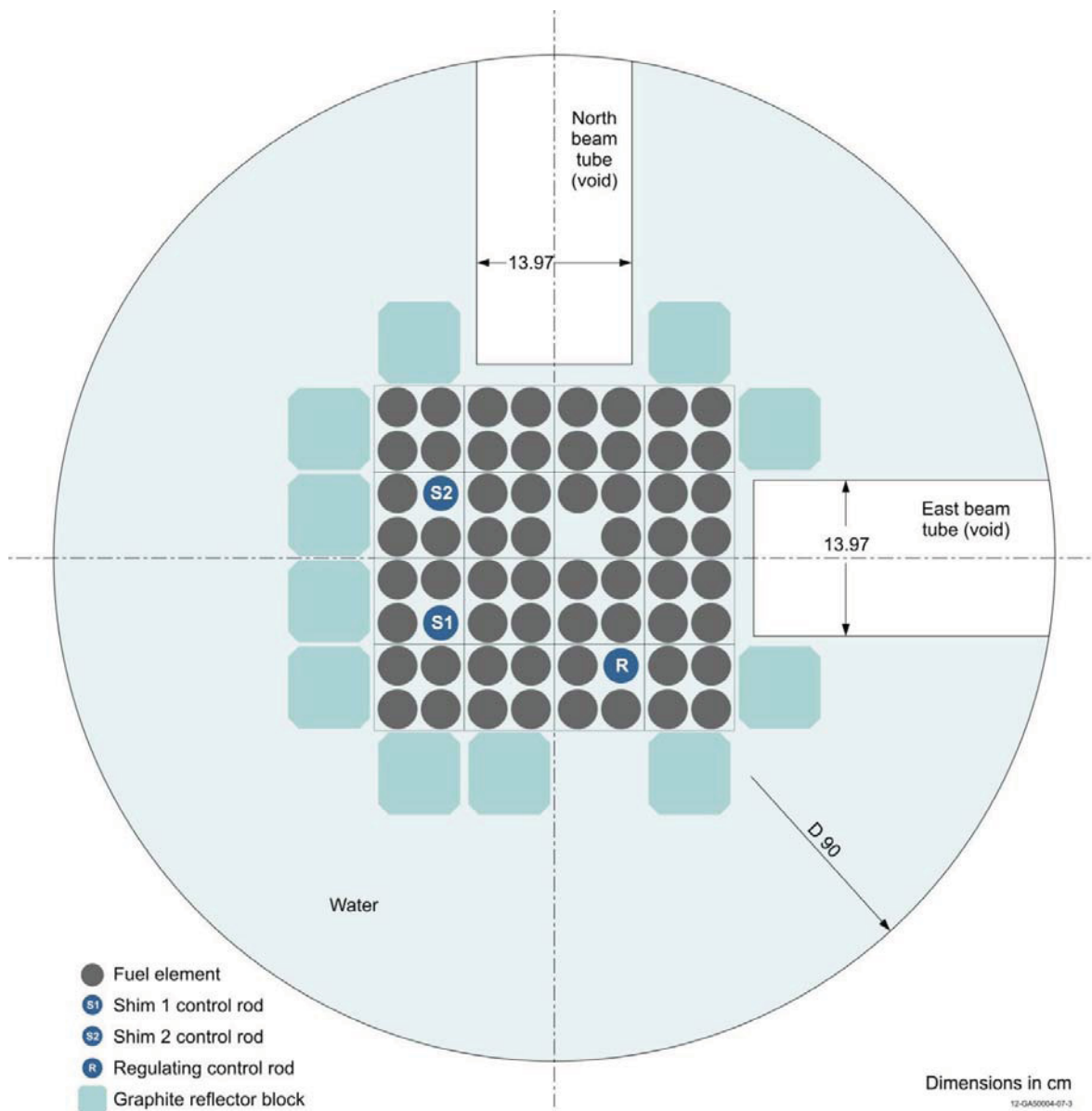

Figure 3.15. Midplane Cross Section View of NRAD Reactor Core without Block in Position F-4.

Table 3.14. Control Rod Positions to Determine Excess Reactivity for Cores with a Single Graphite Reflector Block Removed.

Case #	Core Description	Measurement (Method)	Position #	Shim Positions (cm)	Reg Position (cm)
11	60 Fuel Elements (Block A-5 Out)	Excess Reactivity (Positive Period)	a1	38.1	22.0599
			a2	38.1	38.1
12	60 Fuel Elements (Block C-1 Out)	Excess Reactivity (Positive Period)	a1	38.1	24.9936
			a2	38.1	38.1
13	60 Fuel Elements (Block D-1 Out)	Excess Reactivity (Positive Period)	a1	38.1	25.1460
			a2	38.1	38.1
14	60 Fuel Elements (Block F-4 Out)	Excess Reactivity (Positive Period)	a1	38.1	24.6507
			a2	38.1	38.1

3.4.2.5 Experiment Dry Tube Worth

The experiment dry tube has an inside diameter of 3.96875 cm and an outside diameter of 4.60375 cm. The bottom thickness of the dry tube is 2.54 cm, and the tube wall extends up to the top surface of the benchmark model (see Figure 3.16). The core configuration is identical to that provided in Section 3.1 for the 60-fuel-element core with the dry tube positioned horizontally and vertically as shown in Figures 3.17 through 3.19. The shim 1, shim 2, and regulating control rods are withdrawn 38.1, 38.1, and 20.4216 cm, respectively. The reactivity difference between this configuration and the original configuration in Section 3.1 (Case 2) is used to determine the worth of the experiment dry tube.

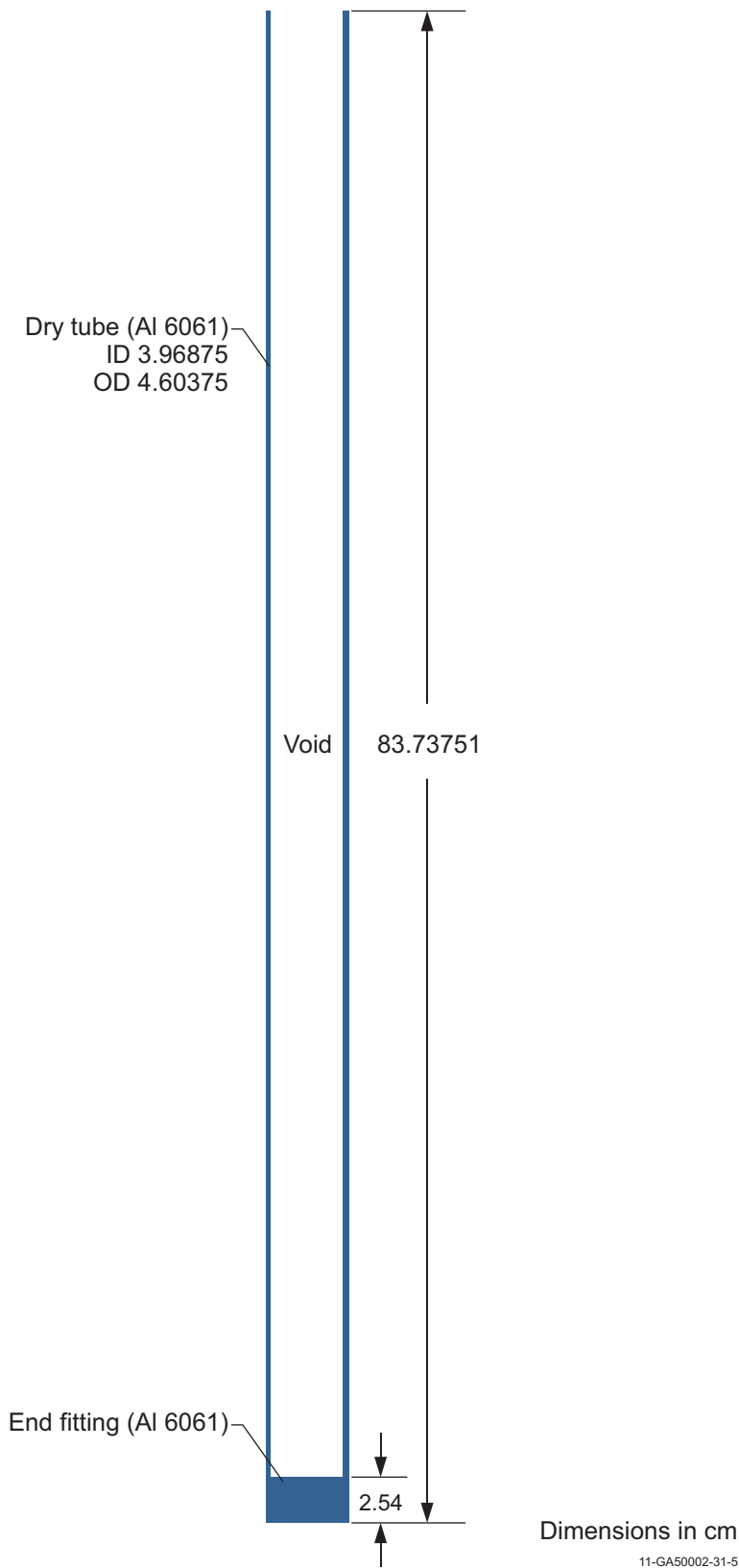

Figure 3.16. Experiment Dry Tube.

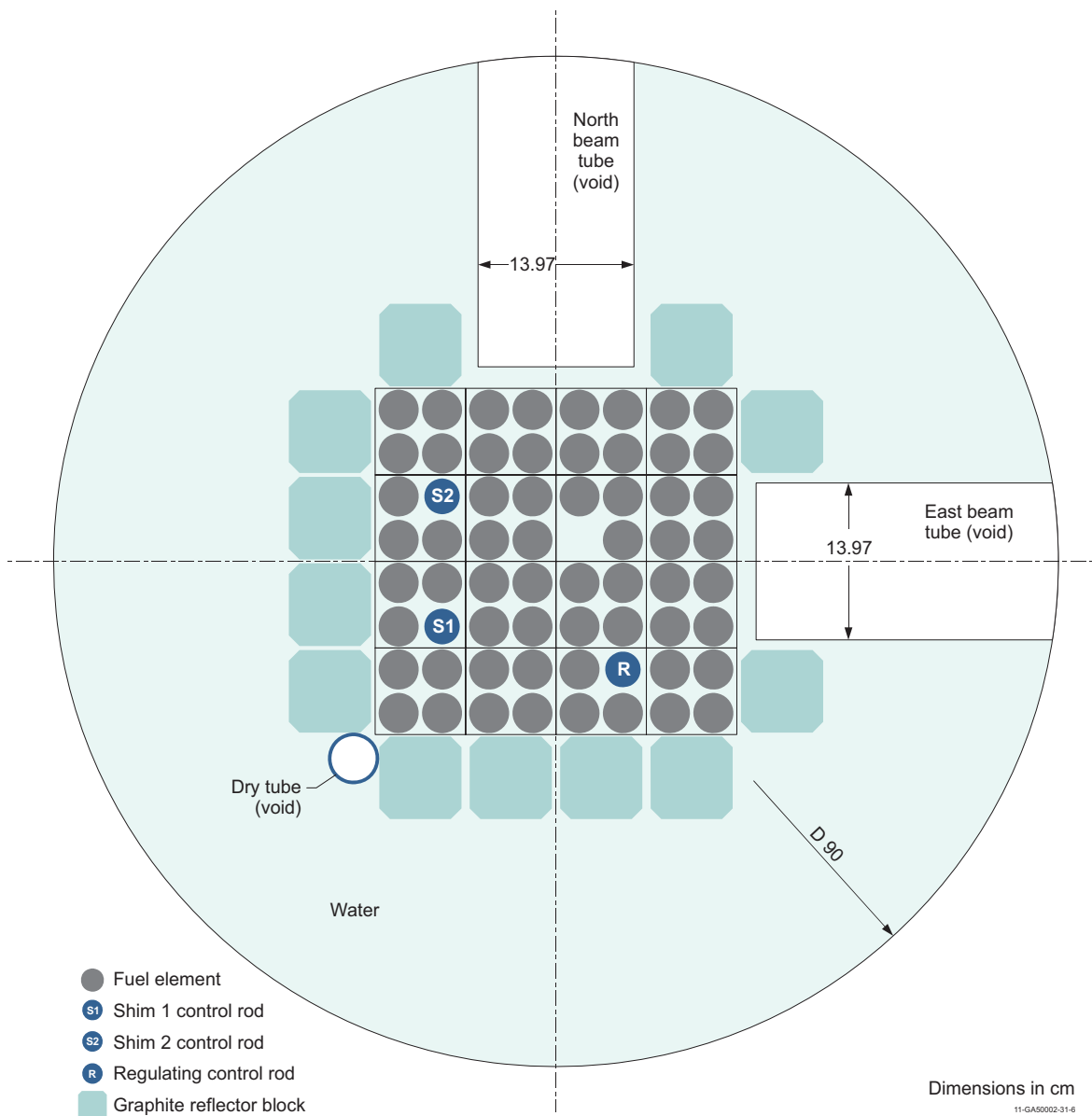
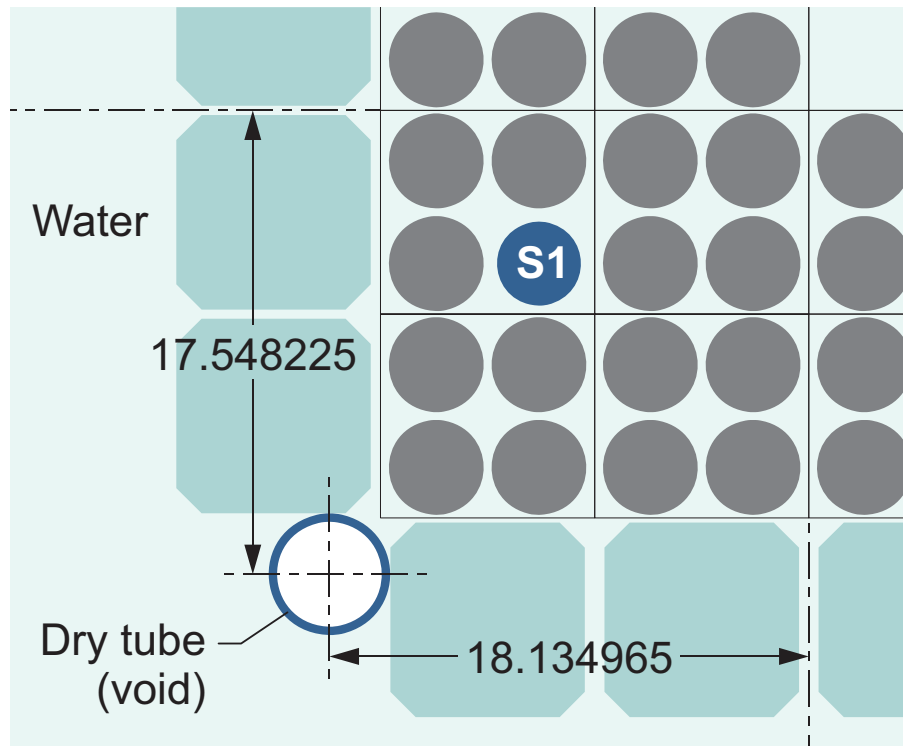

Figure 3.17. Midplane Cross Section View of NRAD Reactor Core with Experiment Dry Tube.



Dimensions in cm

11-GA50002-31-7

Figure 3.18. Placement of Experiment Dry Tube in NRAD Reactor Core.

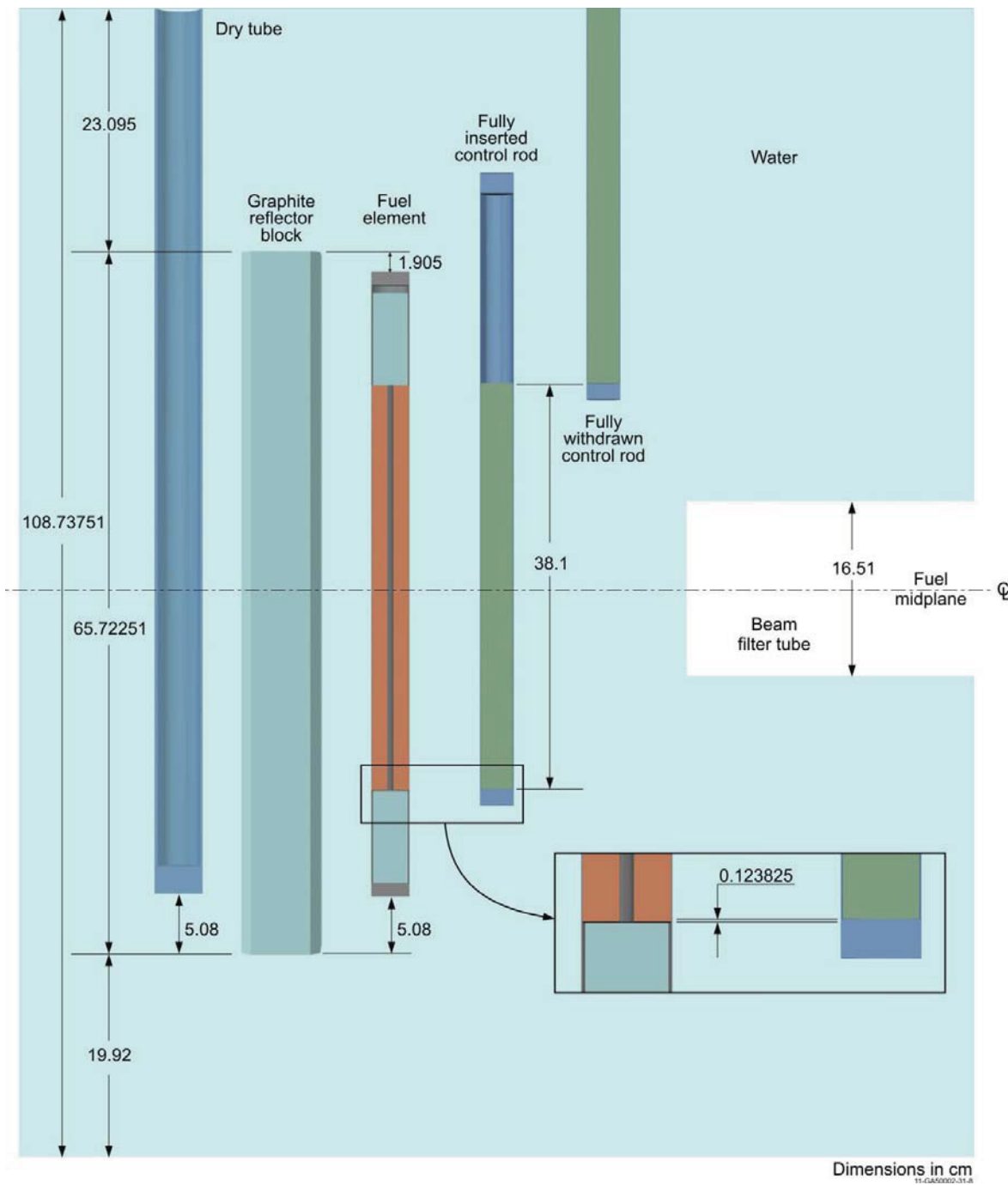

Figure 3.19. NRAD Reactor Core Reference Vertical Placement with Experiment Dry Tube.

3.4.3 Material Data

The materials of the benchmark models for determination of the reactivity effects measurements in the NRAD reactor are identical to those of the critical core configurations described in Section 3.1.2.

The composition of the aluminum 6061 dry tube is provided in Section 3.1.3.8 and Table 3.9. The inside of the tube is void.

3.4.4 Temperature Data

The benchmark model temperature is 300 K.

3.4.5 Benchmark-Model Specification for Reactivity Effects Parameters

The experimental measurements are evaluated in Section 2.4 and summarized in Table 2.73. Whereas there was no additional bias determined for model simplifications, these values represent the benchmark experiment worths, and are provided in Table 3.15.

Table 3.15. Benchmark Experiment Reactivity Effects Measurements.

Case #	Core Description	Measurement	Worth		
			$\rho\%$	\pm	1σ
1	56 Fuel Elements	Shim 1 Worth	-2.76	\pm	0.31
2	56 Fuel Elements	Shim 2 Worth	-2.72	\pm	0.30
3	56 Fuel Elements	Reg Worth	-2.43	\pm	0.23
4	60 Fuel Elements	Shim 1 Worth	-2.68	\pm	0.30
5	60 Fuel Elements	Shim 2 Worth	-2.75	\pm	0.33
6	60 Fuel Elements	Reg Worth	-2.42	\pm	0.16
7	56 Fuel Elements	Shutdown Margin	-7.54	\pm	0.49
8	60 Fuel Elements	Shutdown Margin	-6.73	\pm	0.47
9	56 Fuel Elements	Excess Reactivity	0.37	\pm	0.02
10	60 Fuel Elements	Excess Reactivity	1.12	\pm	0.05
11	60 Fuel Elements	Block A-5 Worth	-0.17	\pm	0.06
12	60 Fuel Elements	Block C-1 Worth	-0.41	\pm	0.06
13	60 Fuel Elements	Block D-1 Worth	-0.43	\pm	0.06
14	60 Fuel Elements	Block F-4 Worth	-0.45	\pm	0.06
15	60 Fuel Elements	Dry Tube Worth	-0.06	\pm	0.01

3.5 Benchmark-Model Specifications for Reactivity Coefficient Measurements

Reactivity coefficient measurements have not been evaluated.

3.6 Benchmark-Model Specifications for Kinetics Measurements

Kinetics measurements were not made.

3.7 Benchmark-Model Specifications for Reaction-Rate Distribution Measurements

Reaction-rate distribution measurements were not made.

3.8 Benchmark-Model Specifications for Power Distribution Measurements

Power distribution measurements were not made.

3.9 Benchmark-Model Specifications for Isotopic Measurements

Isotopic measurements were not made.

3.10 Benchmark-Model Specifications for Other Miscellaneous Types of Measurements

Other miscellaneous types of measurements were not made.

4.0 RESULTS OF SAMPLE CALCULATIONS

4.1 Results of Calculations of the Critical or Subcritical Configurations

The benchmark models described in Section 3.1 were modeled using MCNP5-1.60 (see Appendix A.1 for input decks) and ENDF/B-VII.0 neutron cross section data. Calculations were performed with 1,550 generations with 100,000 neutrons per generation. The k_{eff} estimates did not include the first 50 generations and are the result of 150,000,000 neutron histories. Eigenvalues were also computed using JEFF-3.1 and JENDL-3.3 libraries for comparison. The JENDL-3.3 analysis was performed with the inclusion of ENDF/B-VII.0 thermal neutron scattering data because it was not available in the JENDL-3.3 library. Thermal neutron scattering, or $S(\alpha,\beta)$, adjusts the neutron cross sections for neutron upscatter at thermal energies and provides scattering data for elements bound with specific materials. ENDF/B-VI.8 results were also provided for comparison against ENDF/B-VII.0 calculations; erbium cross sections were unavailable in ENDF/B-VI.8, so ENDF/B-VII.0 cross sections were used.

Calculations were repeated using both continuous-energy and 238-group ENDF/B-VII.0 neutron cross section data in KENO-VI^a using the same number of cycles and histories as those used in MCNP5. An average pitch of 3.95224 cm was used with the KENO-VI analysis with the 238-group ENDF/B-VII.0 data.

Calculations were also performed using SERPENT (version 1.1.17),^b another Monte Carlo code similar to MCNP and KENO-VI, but uses the Woodcock delta-tracking method.^c This version of the code was modified to properly utilize thermal scattering data for hydrogen and zirconium in the ZrH fuel matrix.^d The SERPENT code utilized the same cross section data libraries as MCNP5 and provides comparable results. SERPENT calculations were performed with 2,550 generations with 100,000 neutrons per generation. The k_{eff} estimates did not include the first 50 generations and are the result of 250,000,000 neutron histories.

Calculated results are shown in Table 4.1. All calculated eigenvalues are greater than the benchmark values but within 1% and within the 3σ uncertainty for Case 1 and Case 2 except for calculations performed using ENDF/B-VII.0 for Case 2, which are within 4σ . Additional calculated parameters and neutron spectra that accompany the calculated eigenvalues in Table 4.1 are provided in Appendix B.

The difference between the calculated eigenvalues for continuous energy ENDF/B-VII.0 cross sections in MCNP5 and KENO-VI is due to thermal scattering treatment in the SCALE 6.1 software; updated libraries are currently in development.^e

The effective computational bias increases as fuel is added to the reactor.

^a D. F. Hollenbach, L. M. Petrie, S. Goluoglu, N. F. Landers, and M. E. Dunn, "KENO-VI: A General Quadratic Version of the KENO Program," ORNL/TM-2005/39 Version 6 Vol. II, Sect. F17, Oak Ridge National Laboratory (January 2009).

^b J. Leppänen, "Development of a New Monte Carlo Reactor Physics Code," D.C. Thesis, Helsinki University of Technology, VTT Publications 640, VTT Technical Research Centre, Finland, (2007).

^c E. R. Woodcock, "Techniques Used in the GEM Code for Monte Carlo Neutronics Calculations in Reactors and Other Systems of Complex Geometry," ANL-7050, Argonne National Laboratory (1965).

^d Personal communications with J. Leppänen at VTT (February 23 - March 1, 2012).

^e Personal communication with B. J. Marshall at ORNL (February 28, 2012).

The calculation bias using MCNP5 with ENDF/B-VII and JEFF-3.1 data is comparable to calculations performed^a using the benchmark of the Slovenian TRIGA reactor.^b The calculated experimental uncertainty in the Slovenian reactor is approximately double the uncertainty in this benchmark experiment. The two reactor core designs are fundamentally different and this may have some effect on the calculated results. Monte Carlo analysis of the TRIGA Mark-II reactor at the Musashi Institute of Technology in Japan using MCNP4A and ENDF/B-V data indicated a computational bias in eigenvalue calculations of about 1.0% $\Delta k/k$.^c Worth calculations, however, were in good agreement with experimental results.^c MCNP modeling of other LEU converted TRIGA reactors also exhibit biases of approximately $\pm 1\%$ $\Delta k/k$.^d The University of Wisconsin Nuclear Reactor (UWNR) experienced a similar problem as the NRAD reactor in that preliminary computations indicated a higher core excess reactivity than what was later measured in the as-built core.^e

More recent investigations in Slovenia have been performed to determine that the ENDF/B-VII.0 nuclear data library does not work as well as ENDF/B-VI.8 or JEFF-3.1 for systems containing UZrH fuel. The highest contribution to the overprediction of k_{eff} is due to cross section data for ⁹¹Zr and the thermal scattering data, $S(\alpha, \beta)$, for hydrogen and zirconium in the ZrH lattice. The study concluded that the higher elastic scattering resonance integral in ENDF/B-VII.0 increases thermal neutron flux by improving neutron thermalization, leading to higher fission rates in the thermal region and consequently increasing k_{eff} . This effect is more pronounced in smaller critical systems.^f

^a Personal communications with Luka Snoj at the Jozef Stefan Institute (October 20, 2010).

^b R. Jeraj and M. Ravnik, "TRIGA Mark II Reactor: U(20) – Zirconium Hydride Fuel Rods in Water with Graphite Reflector," Rev. 0 (September 30, 1999), IEU-COMP-THERM-003, *International Handbook of Evaluated Criticality Safety Benchmark Experiments*, NEA/NSC/DOC(95)03, OECD-NEA (2010).

^c T. Matsumoto and N. Hayakawa, "Benchmark Analysis of TRIGA Mark II Reactivity Experiment Using a Continuous Energy Monte Carlo Code MCNP," *J. Nucl. Sci. Technol.*, **37**, 1082-1087 (2000).

^d Personal communications with Chris Ellis at General Atomics and Eric C. Woolstenhulme, Ken Schreck, Randy Damiana, and Ann Marie Philips at INL (August 4, 2010).

^e K. T. Austin, "LEU Core Design for the Conversion of University of Wisconsin Nuclear Reactor," *Proc. RERTR 2010*, Lisbon, Portugal (October 10-13, 2010).

^f L. Snoj, G. Žerovnik, and A. Trkov, "Analysis of Cross Section Libraries on Zirconium Benchmarks," *Proc. International Conference on Nuclear Criticality (ICNC) 2011*, Edinburgh, Scotland (September 19-23, 2011).

Table 4.1a. Comparison of Benchmark Eigenvalues (Case 1).

Analysis Code	Neutron Cross Section Library	Calculated		Benchmark		$\frac{C-E}{E}$ (%)
		k_{eff}	$\pm \sigma$	k_{eff}	$\pm \sigma$	
MCNP5	ENDF/B-VII.0	1.00906	± 0.00007	1.0014	± 0.0029	0.76
	JEFF-3.1	1.00712	± 0.00007			0.57
	JENDL-3.3 ^(a)	1.00616	± 0.00007			0.48
	ENDF/B-VI.8 ^(b)	1.00437	± 0.00007			0.30
KENO-VI	ENDF/B-VII.0 (238-group)	1.00901	± 0.00007			0.76
	ENDF/B-VII.0 (continuous energy) ^(c)	1.00433	± 0.00008			0.29
SERPENT	ENDF/B-VII.0	1.00912	± 0.00008	0.77		

(a) $S(\alpha,\beta)$ data from the ENDF/B-VII.0 library were used with the JENDL-3.3 cross section data..

(b) ENDF/B-VII.0 cross section data for erbium isotopes were used.

(c) This value is calculated to be 1.00898 ± 0.00008 using updated thermal scattering data and treatments currently in development for the SCALE software package. Personal communication with B. J. Marshall at ORNL (May 10, 2012).

Table 4.1b. Comparison of Benchmark Eigenvalues (Case 2).

Analysis Code	Neutron Cross Section Library	Calculated		Benchmark		$\frac{C-E}{E}$ (%)
		k_{eff}	$\pm \sigma$	k_{eff}	$\pm \sigma$	
MCNP5	ENDF/B-VII.0	1.01029	± 0.00007	1.0010	± 0.0025	0.93
	JEFF-3.1	1.00822	± 0.00007			0.72
	JENDL-3.3 ^(a)	1.00731	± 0.00007			0.63
	ENDF/B-VI.8 ^(b)	1.00558	± 0.00007			0.46
KENO-VI	ENDF/B-VII.0 (238-group)	1.01041	± 0.00007			0.94
	ENDF/B-VII.0 (continuous energy) ^(c)	1.00550	± 0.00008			0.45
SERPENT	ENDF/B-VII.0	1.01032	± 0.00008	0.93		

(a) $S(\alpha,\beta)$ data from the ENDF/B-VII.0 library were used with the JENDL-3.3 cross section data..

(b) ENDF/B-VII.0 cross section data for erbium isotopes were used.

(c) This value is calculated to be 1.00933 ± 0.00007 using updated thermal scattering data and treatments currently in development for the SCALE software package. Personal communication with B. J. Marshall at ORNL (February 28, 2012).

4.2 Results of Buckling and Extrapolation Length Calculations

Buckling and extrapolation length measurements were not made.

4.3 Results of Spectral-Characteristics Calculations

Spectral characteristics measurements were not made.

4.4 Results of Reactivity-Effects Calculations

The benchmark models described in Section 3.4 were modeled using MCNP5-1.60 (see Appendix A.1 and A.4 for input decks) and ENDF/B-VII.0 neutron cross section data. Calculations were performed with 1,550 generations with 100,000 neutrons per generation. The k_{eff} estimates did not include the first 50 generations and are the result of 150,000,000 neutron histories. The difference between various configurations, as described in Section 3.4.2, were simulated to calculate reactivity worths ($\Delta k/k$). These worths were then converted into units of $\rho\beta$ using a β_{eff} value of 0.00750 ± 0.000375 (5 %, 1σ). The Monte Carlo statistical uncertainty is approximately \$0.01. The uncertainty in the calculated values provided in this section also include the uncertainty in β_{eff} because of the variability in reported and calculated values (see Section 2.4.1); therefore, calculations using additional neutron cross section libraries were not performed.

4.4.1 Control Rod Worths**4.4.1.1 Shim Rod Worths**

Shim control rod worths were calculated as described in Section 3.4.2.1 and the results are provided in Table 4.2. Calculated and benchmark results are within the 1σ uncertainty.

An alternative calculation method was performed using variations of the benchmark models with all three control rods fully withdrawn to estimate the worth of a single dropped shim rod. Results are provided in Table 4.3. Calculated and benchmark results are within the 1σ uncertainty. Except for Case 4, the alternative method for calculating the shim rod worths is comparable to the benchmark method.

Table 4.2. Comparison of Benchmark Shim Rod Worths.

Case #	Core Description	Measurement (Method)	Benchmark		Calculated		C/E \pm 1σ
			$\rho\beta$	\pm 1σ	$\rho\beta$	\pm 1σ	
1	56 Fuel Elements	Shim 1 Worth (Rod Drop)	-2.76	\pm 0.31	-3.04	\pm 0.15	1.10 \pm 0.14
2	56 Fuel Elements	Shim 2 Worth (Rod Drop)	-2.72	\pm 0.30	-2.60	\pm 0.13	0.96 \pm 0.12
4	60 Fuel Elements	Shim 1 Worth (Rod Drop)	-2.68	\pm 0.30	-2.79	\pm 0.14	1.04 \pm 0.13
5	60 Fuel Elements	Shim 2 Worth (Rod Drop)	-2.75	\pm 0.33	-2.63	\pm 0.13	0.95 \pm 0.12

Table 4.3. Alternative Calculation of Shim Rod Worths.

Case #	Core Description	Measurement (Method)	Benchmark		Calculated		C/E \pm 1 σ	
			$\rho\%$	\pm 1 σ	$\rho\%$	\pm 1 σ		
1	56 Fuel Elements	Shim 1 Worth (Rod Drop)	-2.76	\pm 0.31	-2.97	\pm 0.15	1.08	\pm 0.13
2	56 Fuel Elements	Shim 2 Worth (Rod Drop)	-2.72	\pm 0.30	-2.52	\pm 0.13	0.93	\pm 0.11
4	60 Fuel Elements	Shim 1 Worth (Rod Drop)	-2.68	\pm 0.30	-2.65	\pm 0.13	0.99	\pm 0.12
5	60 Fuel Elements	Shim 2 Worth (Rod Drop)	-2.75	\pm 0.33	-2.35	\pm 0.12	0.85	\pm 0.11

4.4.1.2 Regulating Rod Worths

Regulating control rod worths were calculated as described in Section 3.4.2.1 and the results are provided in Table 4.4; the intermediate steps needed to obtain the final measured value was also calculated and compared against the experimental results. Calculated and benchmark results are within the 1 σ uncertainty.

An alternative calculation method was performed using variations of the benchmark models with all three control rods fully withdrawn to estimate the worth of a single dropped regulating rod. Results are provided in Table 4.5. Calculated and benchmark results are within the 1 σ uncertainty. The alternative method for calculating the regulating rod worths is comparable to the benchmark method.

Table 4.4a. Comparison of Steps to Determine Benchmark Regulating Rod Worths.

Case #	Core Description	Measurement (Method)	Position #	Experiment		Calculated		C/E ^(a) \pm 1 σ	
				$\rho\%$	\pm 1 σ	$\rho\%$	\pm 1 σ		
3	56 Fuel Elements	Partial Reg Worth (Rod Drop)	a	-2.06	\pm 0.23	-2.19	\pm 0.11	1.06	\pm 0.13
			b	0.14	\pm 0.02	0.16	\pm 0.01	1.19	\pm 0.17
		Partial Reg Worth (Positive Period)	c	0.13	\pm 0.01	0.14	\pm 0.01	1.09	\pm 0.16
			d	0.11	\pm 0.01	0.13	\pm 0.01	1.21	\pm 0.19
6	60 Fuel Elements	Partial Reg Worth (Rod Drop)	a	-1.21	\pm 0.14	-1.24	\pm 0.06	1.03	\pm 0.13
			b	0.15	\pm 0.02	0.14	\pm 0.01	0.95	\pm 0.14
		Partial Reg Worth (Positive Period)	c	0.17	\pm 0.02	0.15	\pm 0.01	0.88	\pm 0.13
			d	0.17	\pm 0.02	0.18	\pm 0.02	1.06	\pm 0.15
			e	0.16	\pm 0.02	0.17	\pm 0.02	1.03	\pm 0.15
			f	0.16	\pm 0.02	0.17	\pm 0.02	1.07	\pm 0.15
			g	0.14	\pm 0.02	0.16	\pm 0.02	1.15	\pm 0.17
			h	0.08	\pm 0.01	0.09	\pm 0.01	1.14	\pm 0.22
			i	0.09	\pm 0.01	0.11	\pm 0.01	1.23	\pm 0.21

(a) Rounding of the benchmark and calculated values results in C/E values slightly different than those provided here.

Table 4.4b. Comparison of Benchmark Regulating Rod Worths.

Case #	Core Description	Measurement (Method)	Benchmark		Calculated		C/E ± 1σ	
			ρ\$	± 1σ	ρ\$	± 1σ		
3	56 Fuel Elements	Reg Worth (Sum)	-2.43	± 0.23	-2.62	± 0.11	1.08	± 0.10
6	60 Fuel Elements	Reg Worth (Sum)	-2.42	± 0.16	-2.42	± 0.08	1.00	± 0.07

Table 4.5. Alternative Calculation of Regulating Rod Worths.

Case #	Core Description	Measurement (Method)	Benchmark		Calculated		C/E ± 1σ	
			ρ\$	± 1σ	ρ\$	± 1σ		
3	56 Fuel Elements	Reg Worth (Rod Drop)	-2.43	± 0.23	-2.61	± 0.13	1.07	± 0.11
6	60 Fuel Elements	Reg Worth (Rod Drop)	-2.42	± 0.16	-2.44	± 0.12	1.01	± 0.07

4.4.2 Shutdown Margins

The shutdown margin is represented by the worth of the control rods inserted into the core at critical. The calculated worths of the shims rods is added to the calculated worth of the partially dropped regulating rod (Tables 4.2 and 4.4a, respectively). The results are provided in Table 4.6. Calculated and benchmark results are within the 1σ uncertainty.

An alternative calculation method was performed using variations of the benchmark models with all three control rods fully inserted; the computed eigenvalues were subtracted from the eigenvalues calculated for the critical configurations (Table 4.1) to estimate the total worth of inserted control rods. Results are provided in Table 4.7. Calculated and benchmark results are within the 2σ uncertainty. The alternative method for calculating the shutdown margins appears to calculate values significantly greater than values obtained using the benchmark method.

Table 4.6. Comparison of Benchmark Shutdown Margins.

Case #	Core Description	Measurement (Method)	Benchmark		Calculated		C/E ± 1σ	
			ρ\$	± 1σ	ρ\$	± 1σ		
7	56 Fuel Elements	Shutdown Margin (Rod Drops)	-7.54	± 0.49	-7.83	± 0.23	1.04	± 0.07
8	60 Fuel Elements	Shutdown Margin (Rod Drops)	-6.73	± 0.47	-6.66	± 0.23	0.99	± 0.08

Table 4.7. Alternative Calculation of Shutdown Margins.

Case #	Core Description	Measurement (Method)	Benchmark		Calculated		C/E ^(a) ± 1σ	
			ρ\$	± 1σ	ρ\$	± 1σ		
7	56 Fuel Elements	Shutdown Margin (Rod Drops)	-7.54	± 0.49	-8.85	± 0.44	1.17	± 0.10
8	60 Fuel Elements	Shutdown Margin (Rod Drops)	-6.73	± 0.47	-7.10	± 0.36	1.06	± 0.09

(a) Rounding of the benchmark and calculated values results in C/E values slightly different than those provided here.

4.4.3 Excess Reactivities

The core excess reactivity is represented by the worth of the control rod withdrawn from the core at critical. The worth of the regulating rod removed from the core is obtained by summing the partial period measurements calculated in Table 4.4a. The results are provided in Table 4.8. Calculated and benchmark results are within the 3σ uncertainty.

An alternative calculation method was performed using variations of the benchmark models with all three control rods fully withdrawn; the computed eigenvalues were subtracted from the eigenvalue calculated for the critical configurations (Table 4.1) to estimate the total worth of withdrawn regulating control rods. Results are provided in Table 4.9. Calculated and benchmark results are within the 3σ uncertainty. The alternative method for calculating the core excess reactivities is comparable to the benchmark method.

Table 4.8. Comparison of Benchmark Excess Reactivities.

Case #	Core Description	Measurement (Method)	Benchmark	Calculated	C/E ^(a) ± 1σ
			ρ\$ ± 1σ	ρ\$ ± 1σ	
9	56 Fuel Elements	Excess Reactivity (Positive Periods)	0.37 ± 0.02	0.43 ± 0.02	1.16 ± 0.10
10	60 Fuel Elements	Excess Reactivity (Positive Periods)	1.12 ± 0.05	1.17 ± 0.04	1.05 ± 0.06

(a) Rounding of the benchmark and calculated values results in C/E values slightly different than those provided here.

Table 4.9. Alternative Calculation of Excess Reactivities.

Case #	Core Description	Measurement (Method)	Benchmark	Calculated	C/E ^(a) ± 1σ
			ρ\$ ± 1σ	ρ\$ ± 1σ	
9	56 Fuel Elements	Excess Reactivity (Positive Period)	0.37 ± 0.02	0.43 ± 0.02	1.15 ± 0.10
10	60 Fuel Elements	Excess Reactivity (Positive Period)	1.12 ± 0.05	1.20 ± 0.06	1.07 ± 0.07

(a) Rounding of the benchmark and calculated values results in C/E values slightly different than those provided here.

4.4.4 Graphite Reflector Block Worths

Graphite reflector block worths were calculated as described in Section 3.4.2.4 and the results are provided in Table 4.10; the intermediate steps needed to obtain the final measured value was also calculated and compared against the experimental results. Calculated and benchmark results are within the 1σ uncertainty.

An alternative calculation method was performed using variations of the benchmark models with each block individually replaced by water; the computed eigenvalues were subtracted from the eigenvalue calculated for the critical configuration (Table 4.1) to estimate the total worth of each graphite reflector block. Results are provided in Table 4.11. Except for Case 14, calculated and benchmark results are within the 1σ uncertainty. The alternative method for calculating the graphite reflector block worths appears to calculate values comparable to the benchmark method.

Table 4.10a. Comparison of Steps to Determine Benchmark Graphite Reflector Block Worths.

Case #	Core Description	Measurement (Method)	Experiment		Calculated		C/E ^(a) ± 1σ
			ρ\$	± 1σ	ρ\$	± 1σ	
11	60 Fuel Elements (Block A-5 Out)	Excess Reactivity (Positive Period)	0.95	± 0.05	1.04	± 0.05	1.09 ± 0.08
12	60 Fuel Elements (Block C-1 Out)	Excess Reactivity (Positive Period)	0.71	± 0.05	0.78	± 0.04	1.10 ± 0.09
13	60 Fuel Elements (Block D-1 Out)	Excess Reactivity (Positive Period)	0.69	± 0.05	0.77	± 0.04	1.10 ± 0.09
14	60 Fuel Elements (Block F-4 Out)	Excess Reactivity (Positive Period)	0.67	± 0.05	0.73	± 0.04	1.09 ± 0.09

(a) Rounding of the benchmark and calculated values results in C/E values slightly different than those provided here.

Table 4.10b. Comparison of Benchmark Graphite Reflector Block Worths.

Case #	Core Description	Measurement (Method)	Benchmark		Calculated		C/E ^(a) ± 1σ
			ρ\$	± 1σ	ρ\$	± 1σ	
11	60 Fuel Elements	A-5 Worth (Difference)	-0.17	± 0.06	-0.13	± 0.06	0.79 ± 0.45
12	60 Fuel Elements	C-1 Worth (Difference)	-0.41	± 0.06	-0.39	± 0.04	0.96 ± 0.18
13	60 Fuel Elements	D-1 Worth (Difference)	-0.43	± 0.06	-0.41	± 0.04	0.95 ± 0.17
14	60 Fuel Elements	F-4 Worth (Difference)	-0.45	± 0.06	-0.44	± 0.04	0.98 ± 0.17

(a) Rounding of the benchmark and calculated values results in C/E values slightly different than those provided here.

Table 4.11. Alternative Calculation of Graphite Reflector Block Worths.

Case #	Core Description	Measurement (Method)	Benchmark		Calculated		C/E ^(a) ± 1σ
			ρ\$	± 1σ	ρ\$	± 1σ	
11	60 Fuel Elements	A-5 Worth (Difference)	-0.17	± 0.06	-0.12	± 0.01	0.72 ± 0.29
12	60 Fuel Elements	C-1 Worth (Difference)	-0.41	± 0.06	-0.38	± 0.02	0.92 ± 0.15
13	60 Fuel Elements	D-1 Worth (Difference)	-0.43	± 0.06	-0.38	± 0.02	0.90 ± 0.15
14	60 Fuel Elements	F-4 Worth (Difference)	-0.45	± 0.06	-0.31	± 0.02	0.70 ± 0.11

(a) Rounding of the benchmark and calculated values results in C/E values slightly different than those provided here.

4.4.5 Experiment Dry Tube Worth

The experiment dry tube worth was calculated as described in Section 3.4.2.5 and the result is provided in Table 4.12. Calculated and benchmark results are within the 2σ uncertainty.

Table 4.12. Comparison of Benchmark Experiment Dry Tube Worths

Case #	Core Description	Measurement (Method)	Benchmark	Calculated	C/E ^(a) ± 1σ
			ρ\$ ± 1σ	ρ\$ ± 1σ	
15	60 Fuel Elements	Dry Tube Worth (Difference)	-0.06 ± 0.01	-0.04 ± 0.01	0.69 ± 0.25

(a) Rounding of the benchmark and calculated values results in a C/E values slightly different than provided here.

4.5 Results of Reactivity Coefficient Calculations

Reactivity coefficient measurements have not been evaluated.

4.6 Results of Kinetics Parameter Calculations

Kinetics measurements were not made.

4.7 Results of Reaction-Rate Distribution Calculations

Reaction-rate distribution measurements were not made.

4.8 Results of Power Distribution Calculations

Power distribution measurements were not made.

4.9 Results of Isotopic Calculations

Isotopic measurements were not made.

4.10 Results of Calculations for Other Miscellaneous Types of Measurements

Other miscellaneous types of measurements were not made.

5.0 REFERENCES

There are no available public references.

APPENDIX A: COMPUTER CODES, CROSS SECTIONS, AND TYPICAL INPUT LISTINGS

A.1 Critical/Subcritical Configurations

A.1.1 Name(s) of code system(s) used.

1. Monte Carlo n-Particle, version 5-1.60 (MCNP5).
2. KENO-VI (SCALE 6.0).
3. SERPENT version 1.1.16.

A.1.2 Bibliographic references for the codes used.

1. X-5 Monte Carlo Team, "MCNP – a General Monte Carlo n-Particle Transport Code, version 5," LA-UR-03-1987, Los Alamos National Laboratory (2003).
2. D. F. Hollenbach, L. M. Petrie, S. Goluoglu, N. F. Landers, and M. E. Dunn, "KENO-VI: A General Quadratic Version of the KENO Program," ORNL/TM-2005/39 Version 6 Vol. II, Sect. F17, Oak Ridge National Laboratory (January 2009).
3. J. Leppänen, "Development of a New Monte Carlo Reactor Physics Code," D.C. Thesis, Helsinki University of Technology, VTT Publications 640, VTT Technical Research Centre, Finland, (2007).

A.1.3 Origin of cross-section data.

The Evaluated Neutron Data File library, ENDF/B-VII.0^a was utilized in the benchmark model analysis. The European Joint Evaluated Fission and Fusion File, JEFF-3.1,^b the Japanese Evaluated Nuclear Data Library, JENDL-3.3,^c and ENDF/B-VI.8^d were also included for a basic evaluative comparison. The JENDL-3.3 analysis was performed with the inclusion of ENDF/BVII.0 thermal neutron scattering data because it was not available with the JENDL-3.3 library. Thermal neutron scattering, or $S(\alpha,\beta)$, adjusts the neutron cross sections for neutron upscatter at thermal energies and provides scattering data for elements bound within specific materials.

A.1.4 Spectral calculations and data reduction methods used.

Not applicable.

A.1.5 Number of energy groups or if continuous-energy cross sections are used in the different phases of calculation.

1. Continuous-energy cross sections (MCNP5 and KENO-VI).
2. 238-group cross sections (KENO-VI).

^a M. B. Chadwick, et al., "ENDF/B-VII.0: Next Generation Evaluated Nuclear Data Library for Nuclear Science and Technology," *Nucl. Data Sheets*, **107**: 2931-3060 (2006).

^b A. Koning, R. Forrest, M. Kellett, R. Mills, H. Henriksson, and Y. Rugama, "The JEFF-3.1 Nuclear Data Library," JEFF Report 21, Organisation for Economic Co-operation and Development, Paris (2006).

^c K. Shibata, et al., "Japanese Evaluated Nuclear Data Library Version 3 Revision3: JENDL-3.3," *J. Nucl. Sci. Tech.*, **39**: 1125-1136 (November 2002).

^d H. D. Lemmel, P. K. McLaughlin, and V. G. Pronyaev, "ENDF/B-VI Release 8 (Last Release of ENDF/B-VI) the U.S. Evaluated Nuclear Data Library for Neutron Reaction Data," IAEA-NDS-100 Rev. 11, International Atomic Energy Agency, Vienna (November 2001).

A.1.6 Component calculations.

- Type of cell calculation – Reactor core, reflectors, and moderator
- Geometry – Fuel pin and assembly lattice
- Theory used – Not applicable
- Method used – Monte Carlo
- Calculation characteristics
 - MCNP5 and KENO-VI – histories/cycles/cycles skipped = 100,000/1,550/50
continuous-energy cross sections
 - KENO-VI – histories/cycles/cycles skipped = 100,000/1,550/50
238-group cross sections
 - SERPENT – histories/cycles/cycles skipped = 100,000/2,550/50
continuous-energy cross sections

A.1.7 Other assumptions and characteristics.

Not applicable.

A.1.8 Typical input listings for each code system type.

MCNP5 Input Deck for the 56-fuel-element initial core configuration (Case 1):

```

INITIAL CRITICAL OF THE NRAD REACTOR WITH U(20)-ER-ZR-H FUEL (SIMPLE)
c
c John Darrell Bess - Idaho National Laboratory
c Last Updated: January 3, 2012
c
c Cell Cards *****
c --- Assemblies -----
c ----- Graphite Reflector -----
201 8 7.8692E-02 (9 -10) (331 -332 333 -334) (-335 -336 -337 -338)
      imp:n=1 u=200 $ Graphite Block
202 1 9.9961E-02 -9:10:-331:332:-333:334:335:336:337:338 imp:n=1 u=200 $ Water Around Assembly
c
c ----- Fuel Rod -----
301 5 8.6851E-02 102 -103 -157 imp:n=1 u=301 $ Bottom End Cap
302 2 8.6734E-02 103 -104 -152 imp:n=1 u=301 $ Bottom Graphite Reflector
303 3 6.4130E-02 104 -105 -153 imp:n=1 u=301 $ Moly Poison Disc
304 4 4.2897E-02 105 -106 -154 imp:n=1 u=301 $ Zirconium Rod
305 0          105 -106 154 -155 imp:n=1 u=301 $ Zr/Fuel Gap
306 9 8.9404E-02 105 -106 155 -156 imp:n=1 u=301 $ Fuel Rod
307 2 8.6734E-02 106 -107 -152 imp:n=1 u=301 $ Top Graphite Reflector
308 0 (-103:104:152) (-104:105:153) (-105:106:156) (-106:107:152)
      (103 -108 -157) imp:n=1 u=301 $ Void Gap
309 5 8.6851E-02 102 -109 157 -158 imp:n=1 u=301 $ Cladding
310 5 8.6851E-02 108 -109 -157 imp:n=1 u=301 $ Top End Cap
311 1 9.9961E-02 158:-102:109 imp:n=1 u=301 $ Water
c
c ----- Control Rods -----
401 7 5.8593E-02 231 -232 -275 imp:n=1 u=401 $ Bottom End Fitting
402 6 1.3514E-01 232 -233 -271 imp:n=1 u=401 $ Absorber
403 0 (232 -233 271 -275):(233 -235 -275) imp:n=1 u=401 $ Void Space
404 7 5.8593E-02 235 -236 -275 imp:n=1 u=401 $ Top End Fitting
405 7 5.8593E-02 231 -236 275 -276 imp:n=1 u=401 $ Cladding
406 1 9.9961E-02 -231:236:276 imp:n=1 u=401 $ Water around Control Rod
c
407 0 3 -13 imp:n=1 u=402 fill=401 (0 0 38.1) $ Shim 1 Control Rod
408 0 3 -13 imp:n=1 u=403 fill=401 (0 0 38.1) $ Shim 2 Control Rod
409 0 3 -13 imp:n=1 u=404 fill=401 (0 0 29.5275) $ Reg Control Rod
c
c * Control Rods are fully inserted when the values in parenthesis are (0 0 0) *
c * Control Rods are fully withdrawn when the values are (0 0 38.1), which *
c * corresponds to 1000 units withdrawn *
c
c ----- 4-Rod Fuel Cluster -----
501 1 9.9961E-02 -132 131 -134 133 imp:n=1 u=101 lat=1 fill=-1:2 -1:2 0:0 $ Fuel Assemblies
      101 101 101 101

```

Fundamental - FUND

NRAD-FUND-RESR-001
CRIT-REAC-COEF

```

101 301 301 101
101 301 301 101
101 101 101 101
502 0 3 -13 imp:n=1 u=300 fill=101 (-1.9431 -1.9431 0) $ Fuel Bundle
c
c ----- Position D-2 : Shim Rod 1 Control Cluster -----
511 1 9.9961E-02 -132 131 -134 133 imp:n=1 u=102 lat=1 fill=-1:2 -1:2 0:0 $ Fuel Assemblies
102 102 102 102
102 301 402 102
102 301 301 102
102 102 102 102
512 0 3 -13 imp:n=1 u=400 fill=102 (-1.9431 -1.9431 0) $ Fuel Bundle
c
c ----- Position C-2 : Shim Rod 2 Control Cluster -----
521 1 9.9961E-02 -132 131 -134 133 imp:n=1 u=103 lat=1 fill=-1:2 -1:2 0:0 $ Fuel Assemblies
103 103 103 103
103 301 301 103
103 301 403 103
103 103 103 103
522 0 3 -13 imp:n=1 u=500 fill=103 (-1.9431 -1.9431 0) $ Fuel Bundle
c
c ----- Position E-4 : Regulating Rod Control Cluster -----
531 1 9.9961E-02 -132 131 -134 133 imp:n=1 u=104 lat=1 fill=-1:2 -1:2 0:0 $ Fuel Assemblies
104 104 104 104
104 301 301 104
104 301 404 104
104 104 104 104
532 0 3 -13 imp:n=1 u=600 fill=104 (-1.9431 -1.9431 0) $ Fuel Bundle
c
c ----- Position C-4 : Sample Irradiation Cluster -----
541 1 9.9961E-02 -132 131 -134 133 imp:n=1 u=105 lat=1 fill=-1:2 -1:2 0:0 $ Fuel Assemblies
105 105 105 105
105 105 301 105
105 301 301 105
105 105 105 105
542 0 3 -13 imp:n=1 u=700 fill=105 (-1.9431 -1.9431 0) $ Fuel Bundle
c
c --- Beam Lines -----
601 0 402 -403 432 -433 431 -434 -71 imp:n=1 $ East Beam Filter Tube
602 0 402 -403 532 -533 531 -534 -71 imp:n=1 $ North Beam Filter Tube
c
c --- NRAD Reactor -----
c ----- Core Map -----
701 1 9.9961E-02 -32 31 -34 33 imp:n=1 u=100 lat=1 fill=-4:5 -4:5 0:0
100 100 100 100 100 100 100 100 100 100
100 100 100 100 100 100 100 100 100 100
100 100 100 200 200 200 200 100 100 100
100 100 200 300 300 600 300 200 100 100
100 100 200 400 300 300 300 100 100 100
100 100 200 500 300 700 300 100 100 100
100 100 200 300 300 300 200 200 100 100
100 100 100 200 100 100 100 100 100 100
100 100 100 100 100 100 100 100 100 100
100 100 100 100 100 100 100 100 100 100
c
c ----- Core Map Legend -----
c H2O H2O H2O H2O H2O H2O H2O H2O H2O
c H2O Grid Grid Grid Grid Grid Grid Grid Grid H2O
c H2O Grid Grid Grph Srce Grph Grph Grid Grid H2O
c H2O Grid Grph Fuel Fuel Reg Fuel Grph Grid H2O
c H2O Grid Grph Shm1 Fuel Fuel Fuel EaBm Grid H2O
c H2O Grid Grph Shm2 Fuel Hole Fuel EaBm Grid H2O
c H2O Grid Grph Fuel Fuel Fuel Grph Grph Grid H2O
c H2O Grid Grid Grph NoBm NoBm Grid Grid Grid H2O
c H2O Grid Grid Grid Grid Grid Grid Grid Grid H2O
c H2O H2O H2O H2O H2O H2O H2O H2O H2O
c
c EaBm = East Beam Support (Modeled as H2O)
c Fuel = Four Fuel Cluster
c Grid = Empty Grid Position (or Grid Edge) (Modeled as H2O)
c Grph = Graphite Block Reflector
c H2O = Water
c Hole = Water Hole (Irradiation Position)
c NoBm = North Beam Support (Modeled as H2O)
c Reg = Regulating Rod Cluster
c Shm1 = Shim Rod 1 Cluster

```

Fundamental - FUND

NRAD-FUND-RESR-001
CRIT-REAC-COEF

```

c      Shm2 = Shim Rod 2 Cluster
c      Srce = Graphite Block Reflector (AmBe Source) (Modeled as Graphite Block)
c
c ----- Core Map Positions -----
c      H2O  H2O  H2O  H2O  H2O  H2O  H2O  H2O  H2O  H2O
c      H2O Grid Grid Grid Grid Grid Grid Grid Grid Grid H2O
c      H2O Grid F-1 F-2 F-3 F-4 F-5 F-6 Grid H2O
c      H2O Grid E-1 E-2 E-3 E-4 E-5 E-6 Grid H2O
c      H2O Grid D-1 D-2 D-3 D-4 D-5 D-6 Grid H2O
c      H2O Grid C-1 C-2 C-3 C-4 C-5 C-6 Grid H2O
c      H2O Grid B-1 B-2 B-3 B-4 B-5 B-6 Grid H2O
c      H2O Grid A-1 A-2 A-3 A-4 A-5 A-6 Grid H2O
c      H2O Grid Grid Grid Grid Grid Grid Grid Grid Grid H2O
c      H2O  H2O  H2O  H2O  H2O  H2O  H2O  H2O  H2O  H2O
c
c      Note: Visual Core Map is Mirrored Vertically Compared to Actual Positions
c
702  0 (-36 35 -38 37 -13 3) (-402:403:-532:533:-531) (-402:403:-432:433:-431)
      imp:n=1 fill=100 (-4.05003 -3.85445 0) $ Core
703  1 9.9961E-02 (36:-35:38:-37) (-402:403:-532:533:-531)
      (-402:403:-432:433:-431) 3 -13 -71 imp:n=1 $ Tank Water
c
c --- Model Boundary -----
901  0 -3:13:71 imp:n=0
c
c Surface Cards *****
c --- Primary Model Dimensions -----
c ----- Horizontal Planes -----
3    pz  42.54876 $ Bottom Model Boundary
9    pz  62.46876 $ Bottom Assembly Boundary
10   pz  128.19127 $ Top Assembly Boundary
13   pz  151.28627 $ Top Model Boundary
c
c ----- Vertical Planes -----
31   px  -4.05003 $ West Assembly Boundary
32   px   4.05003 $ East Assembly Boundary
33   py  -3.85445 $ South Assembly Boundary
34   py   3.85445 $ North Assembly Boundary
35   px  -24.31415 $ West Edge of Grid Plate
36   px   24.31415 $ East Edge of Grid Plate
37   py  -23.33625 $ South Edge of Grid Plate
38   py   23.33625 $ North Edge of Grid Plate
c
c ----- Radii -----
71   cz  45      $ Radial Model Boundary
c
c --- Fuel Rods -----
c ----- Horizontal Planes -----
102  pz  67.54876 $ Bottom of Clad Tube
103  pz  68.81876 $ Bottom End Fitting/Bottom Graphite Reflector Interface
104  pz  77.50556 $ Bottom Graphite Reflector/Moly Disc Interface
105  pz  77.584935 $ Moly Disc/Fuel Rods Interface
106  pz  115.604935 $ Fuel Rods/Top Graphite Reflector Interface
107  pz  124.291735 $ Top Graphite Reflector/Void Gap Interface
108  pz  125.01627 $ Void Gap/Top End Fitting Interface
109  pz  126.28627 $ Top of Clad Tube
c
c ----- Vertical Planes -----
131  px  -1.9431  $ West Fuel Boundary
132  px   1.9431  $ East Fuel Boundary
133  py  -1.9431  $ South Fuel Boundary
134  py   1.9431  $ North Fuel Boundary
c
c ----- Radii -----
152  cz  1.63957  $ Axial Graphite Reflectors
153  cz  1.73482  $ Moly Poison Disc
154  cz  0.28575  $ Zirconium Rods
155  cz  0.3175   $ Fuel Rod ID
156  cz  1.74025  $ Fuel Rod OD
157  cz  1.7447   $ Cladding Inner Surface
158  cz  1.7955   $ Cladding Outer Surface
c
c --- Control Rods -----
c ----- Horizontal Planes -----
231  pz  76.12126 $ Bottom of Control Rod Clad

```

Fundamental - FUND

NRAD-FUND-RESR-001
CRIT-REAC-COEF

```

232 pz 77.70876 $ Clad/B4C Rod Interface
233 pz 115.80876 $ B4C Rod/Void Interface
235 pz 133.58876 $ Void/Clad Interface
236 pz 135.55726 $ Top of Control Rod Clad
c
c ----- Radii -----
271 cz 1.50749 $ B4C Outer Surface
275 cz 1.51638 $ Cladding Inner Surface
276 cz 1.5875 $ Cladding Outer Surface
c
c --- Graphite Reflector Assemblies -----
c ----- Vertical Planes -----
331 px -3.683 $ West Graphite Surface
332 px 3.683 $ East Graphite Surface
333 py -3.683 $ South Graphite Surface
334 py 3.683 $ North Graphite Surface
335 p -3.683 2.7305 1 -3.683 2.7305 -1 -2.7305 3.683 1 $ NW Chamfer
336 p 3.683 2.7305 1 3.683 2.7305 -1 2.7305 3.683 1 $ NE Chamfer
337 p -3.683 -2.7305 1 -3.683 -2.7305 -1 -2.7305 -3.683 1 $ SW Chamfer
338 p 3.683 -2.7305 1 3.683 -2.7305 -1 2.7305 -3.683 1 $ SE Chamfer
c
c --- Beam Lines -----
c ----- Horizontal Planes -----
402 pz 88.33993 $ Bottom Surface of Beam Filter Tubes
403 pz 104.84993 $ Top Surface of Beam Filter Tubes
c
c ----- Vertical Planes -----
c ----- East Beam Assembly -----
431 px 17.92069 $ Core Face of Beam Filter Tube
432 py -6.985 $ South Surface of Beam Filter Tube
433 py 6.985 $ North Surface of Beam Filter Tube
434 px 51.57597 $ Back End of Beam Filter Tube
c
c ----- North Beam Assembly -----
531 py 17.33395 $ Core Face of West Beam Filter Tube
532 px -6.985 $ East Surface of West Beam Filter Tube
533 px 6.985 $ West Surface of West Beam Filter Tube
534 py 52.54498 $ Back End of Beam Filter Tube
c
c Data Cards *****
c
c *** Material Cards *****
c --- Water -----
m1 1001.70c 6.6633E-02 1002.70c 7.6637E-06 8016.70c 3.3308E-02
8017.70c 1.2662E-05
c Total 9.9961E-02
mt1 lwtr.10t hwtr.10t
c
c --- Fuel Rods (Non-Fuel Components) -----
c ----- Axial Graphite Reflectors -----
m2 6000.70c 8.6734E-02
c Total 8.6734E-02
mt2 grph.10t
c
c ----- Moly Poison Disc -----
m3 42092.70c 9.5169E-03 42094.70c 5.9320E-03 42095.70c 1.0210E-02
42096.70c 1.0697E-02 42097.70c 6.1244E-03 42098.70c 1.5475E-02
42100.70c 6.1757E-03
c Total 6.4130E-02
c
c ----- Zr Rod -----
m4 40090.70c 2.2070E-02 40091.70c 4.8130E-03 40092.70c 7.3568E-03
40094.70c 7.4555E-03 40096.70c 1.2011E-03
c Total 4.2897E-02
c
c ----- SS 304 Cladding and End Fittings -----
m5 6000.70c 1.6044E-04 14028.70c 6.3283E-04 14029.70c 3.2134E-05
14030.70c 2.1183E-05 15031.70c 4.0441E-05 16032.70c 3.1374E-06
16033.70c 2.5117E-08 16034.70c 1.4178E-07 16036.70c 6.6099E-10
24050.70c 7.6491E-04 24052.70c 1.4751E-02 24053.70c 1.6726E-03
24054.70c 4.1634E-04 25055.70c 8.7693E-04 26054.70c 3.4644E-03
26056.70c 5.4383E-02 26057.70c 1.2559E-03 26058.70c 1.6714E-04
28058.70c 5.5882E-03 28060.70c 2.1526E-03 28061.70c 9.3571E-05
28062.70c 2.9834E-04 28064.70c 7.5980E-05
c Total 8.6851E-02

```

Fundamental - FUND

NRAD-FUND-RESR-001
CRIT-REAC-COEF

```

mt5   fe56.12t
c
c --- Control Rods -----
c ----- B4C Absorber -----
m6    5010.70c 2.1515E-02  5011.70c 8.6601E-02  6000.70c 2.7029E-02
c     Total    1.3514E-01
mt6   grph.10t
c
c ----- Al 6061 Cladding and End Fittings -----
m7    13027.70c 5.8593E-02
c     Total    5.8593E-02
mt7   al27.12t
c
c --- Graphite Reflector Assemblies -----
c ----- Graphite Reflectors -----
m8    6000.70c 7.8692E-02
c     Total    7.8692E-02
mt8   grph.10t
c
c ----- 56-Rod-Average UErZrH Fuel Rod Composition -----
m9    92234.70c 9.9283E-06  92235.70c 1.0836E-03  92236.70c 1.2032E-05
      92238.70c 4.3312E-03  5010.70c 7.6273E-08  5011.70c 3.0701E-07
      1001.70c 5.0614E-02  1002.70c 5.8213E-06  6000.70c 1.0781E-03
      40090.70c 1.6483E-02  40091.70c 3.5945E-03  40092.70c 5.4942E-03
      40094.70c 5.5679E-03  40096.70c 8.9701E-04  68162.70c 3.2516E-07
      68164.70c 3.7393E-06  68166.70c 7.8061E-05  68167.70c 5.3256E-05
      68168.70c 6.2198E-05  68170.70c 3.4676E-05  72174.70c 1.3204E-09
      72176.70c 4.3408E-08  72177.70c 1.5350E-07  72178.70c 2.2513E-07
      72179.70c 1.1240E-07  72180.70c 2.8950E-07
c     Total    8.9404E-02
mt9   h/zr.10t zr/h.10t
c
c
c *** Control Cards *****
mode  n
kcode 100000 1 50 1550
ksrc  -1.9431 -1.9431 96.6  1.9431  1.9431 96.6
      -5.8293  5.8293 96.6  5.8293  -5.8293 96.6
      -9.7155 -9.7155 96.6  9.7155  9.7155 96.6
      -13.6017 13.6017 96.6 13.6017 -13.6017 96.6
      -13.6017 0.0 96.6 13.6017 0.0 96.6
      0.0 13.6017 96.6 0.0 -13.6017 96.6
print
kopts  blocksize=10 kinetics=yes precursor=yes
c

```

Fundamental - FUND

NRAD-FUND-RESR-001
CRIT-REAC-COEF*MCNP5 Input Deck for the 60-fuel-element operational core configuration (Case 2):*

```

FRESH-CORE RELOAD OF THE NRAD REACTOR WITH U(20)-ER-ZR-H FUEL (SIMPLE)
c
c John Darrell Bess - Idaho National Laboratory
c Last Updated: January 3, 2012
c
c Cell Cards *****
c --- Assemblies -----
c ----- Graphite Reflector -----
201  8 7.8692E-02 (9 -10) (331 -332 333 -334) (-335 -336 -337 -338)
      imp:n=1 u=200 $ Graphite Block
202  1 9.9928E-02 -9:10:-331:332:-333:334:335:336:337:338 imp:n=1 u=200 $ Water Around Assembly
c
c ----- Fuel Rod -----
301  5 8.6851E-02 102 -103 -157 imp:n=1 u=301 $ Bottom End Cap
302  2 8.6734E-02 103 -104 -152 imp:n=1 u=301 $ Bottom Graphite Reflector
303  3 6.4130E-02 104 -105 -153 imp:n=1 u=301 $ Moly Poison Disc
304  4 4.2897E-02 105 -106 -154 imp:n=1 u=301 $ Zirconium Rod
305  0      105 -106 154 -155 imp:n=1 u=301 $ Zr/Fuel Gap
306  9 8.9397E-02 105 -106 155 -156 imp:n=1 u=301 $ Fuel Rod
307  2 8.6734E-02 106 -107 -152 imp:n=1 u=301 $ Top Graphite Reflector
308  0 (-103:104:152) (-104:105:153) (-105:106:156) (-106:107:152)
      (103 -108 -157) imp:n=1 u=301 $ Void Gap
309  5 8.6851E-02 102 -109 157 -158 imp:n=1 u=301 $ Cladding
310  5 8.6851E-02 108 -109 -157 imp:n=1 u=301 $ Top End Cap
311  1 9.9928E-02 158:-102:109 imp:n=1 u=301 $ Water
c
c ----- Control Rods -----
401  7 5.8593E-02 231 -232 -275 imp:n=1 u=401 $ Bottom End Fitting
402  6 1.3514E-01 232 -233 -271 imp:n=1 u=401 $ Absorber
403  0 (232 -233 271 -275):(233 -235 -275) imp:n=1 u=401 $ Void Space
404  7 5.8593E-02 235 -236 -275 imp:n=1 u=401 $ Top End Fitting
405  7 5.8593E-02 231 -236 275 -276 imp:n=1 u=401 $ Cladding
406  1 9.9928E-02 -231:236:276 imp:n=1 u=401 $ Water around Control Rod
c
407  0 3 -13 imp:n=1 u=402 fill=401 (0 0 38.1) $ Shim 1 Control Rod
408  0 3 -13 imp:n=1 u=403 fill=401 (0 0 38.1) $ Shim 2 Control Rod
409  0 3 -13 imp:n=1 u=404 fill=401 (0 0 20.4216) $ Reg Control Rod
c
c * Control Rods are fully inserted when the values in parenthesis are (0 0 0) *
c * Control Rods are fully withdrawn when the values are (0 0 38.1), which *
c * corresponds to 1000 units withdrawn *
c
c ----- 4-Rod Fuel Cluster -----
501  1 9.9928E-02 -132 131 -134 133 imp:n=1 u=101 lat=1 fill=-1:2 -1:2 0:0 $ Fuel Assemblies
      101 101 101 101
      101 301 301 101
      101 301 301 101
      101 101 101 101
502  0 3 -13 imp:n=1 u=300 fill=101 (-1.9431 -1.9431 0) $ Fuel Bundle
c
c ----- Position D-2 : Shim Rod 1 Control Cluster -----
511  1 9.9928E-02 -132 131 -134 133 imp:n=1 u=102 lat=1 fill=-1:2 -1:2 0:0 $ Fuel Assemblies
      102 102 102 102
      102 301 402 102
      102 301 301 102
      102 102 102 102
512  0 3 -13 imp:n=1 u=400 fill=102 (-1.9431 -1.9431 0) $ Fuel Bundle
c
c ----- Position C-2 : Shim Rod 2 Control Cluster -----
521  1 9.9928E-02 -132 131 -134 133 imp:n=1 u=103 lat=1 fill=-1:2 -1:2 0:0 $ Fuel Assemblies
      103 103 103 103
      103 301 301 103
      103 301 403 103
      103 103 103 103
522  0 3 -13 imp:n=1 u=500 fill=103 (-1.9431 -1.9431 0) $ Fuel Bundle
c
c ----- Position E-4 : Regulating Rod Control Cluster -----
531  1 9.9928E-02 -132 131 -134 133 imp:n=1 u=104 lat=1 fill=-1:2 -1:2 0:0 $ Fuel Assemblies
      104 104 104 104
      104 301 301 104
      104 301 404 104
      104 104 104 104
532  0 3 -13 imp:n=1 u=600 fill=104 (-1.9431 -1.9431 0) $ Fuel Bundle

```

Fundamental - FUND

NRAD-FUND-RESR-001
CRIT-REAC-COEF

```

c
c ----- Position C-4 : Sample Irradiation Cluster -----
541 1 9.9928E-02 -132 131 -134 133 imp:n=1 u=105 lat=1 fill=-1:2 -1:2 0:0 $ Fuel Assemblies
    105 105 105 105
    105 105 301 105
    105 301 301 105
    105 105 105 105
542 0 3 -13 imp:n=1 u=700 fill=105 (-1.9431 -1.9431 0) $ Fuel Bundle
c
c --- Beam Lines -----
601 0 402 -403 432 -433 431 -434 -71 imp:n=1 $ East Beam Filter Tube
602 0 402 -403 532 -533 531 -534 -71 imp:n=1 $ North Beam Filter Tube
c
c --- NRAD Reactor -----
c ----- Core Map -----
701 1 9.9928E-02 -32 31 -34 33 imp:n=1 u=100 lat=1 fill=-4:5 -4:5 0:0
    100 100 100 100 100 100 100 100 100 100
    100 100 100 100 100 100 100 100 100 100
    100 100 100 200 200 200 200 100 100 100
    100 100 200 300 300 600 300 200 100 100
    100 100 200 400 300 300 300 100 100 100
    100 100 200 500 300 700 300 100 100 100
    100 100 200 300 300 300 300 200 100 100
    100 100 100 200 100 100 200 100 100 100
    100 100 100 100 100 100 100 100 100 100
    100 100 100 100 100 100 100 100 100 100
c
c ----- Core Map Legend -----
c H2O H2O H2O H2O H2O H2O H2O H2O H2O H2O
c H2O Grid Grid Grid Grid Grid Grid Grid Grid Grid H2O
c H2O Grid Grid Grph Srce Grph Grph Grid Grid H2O
c H2O Grid Grph Fuel Fuel Reg Fuel Grph Grid H2O
c H2O Grid Grph Shm1 Fuel Fuel Fuel EaBm Grid H2O
c H2O Grid Grph Shm2 Fuel Hole Fuel EaBm Grid H2O
c H2O Grid Grph Fuel Fuel Fuel Fuel Grph Grid H2O
c H2O Grid Grid Grph NoBm NoBm Grph Grid Grid H2O
c H2O Grid Grid Grid Grid Grid Grid Grid Grid H2O
c H2O H2O H2O H2O H2O H2O H2O H2O H2O H2O
c
c EaBm = East Beam Support (Modeled as H2O)
c Fuel = Four Fuel Cluster
c Grid = Empty Grid Position (or Grid Edge) (Modeled as H2O)
c Grph = Graphite Block Reflector
c H2O = Water
c Hole = Water Hole (Irradiation Position)
c NoBm = North Beam Support (Modeled as H2O)
c Reg = Regulating Rod Cluster
c Shm1 = Shim Rod 1 Cluster
c Shm2 = Shim Rod 2 Cluster
c Srce = Graphite Block Reflector (AmBe Source) (Modeled as Graphite Block)
c
c ----- Core Map Positions -----
c H2O H2O H2O H2O H2O H2O H2O H2O H2O H2O
c H2O Grid Grid Grid Grid Grid Grid Grid Grid Grid H2O
c H2O Grid F-1 F-2 F-3 F-4 F-5 F-6 Grid H2O
c H2O Grid E-1 E-2 E-3 E-4 E-5 E-6 Grid H2O
c H2O Grid D-1 D-2 D-3 D-4 D-5 D-6 Grid H2O
c H2O Grid C-1 C-2 C-3 C-4 C-5 C-6 Grid H2O
c H2O Grid B-1 B-2 B-3 B-4 B-5 B-6 Grid H2O
c H2O Grid A-1 A-2 A-3 A-4 A-5 A-6 Grid H2O
c H2O Grid Grid Grid Grid Grid Grid Grid Grid H2O
c H2O H2O H2O H2O H2O H2O H2O H2O H2O H2O
c
c Note: Visual Core Map is Mirrored Vertically Compared to Actual Positions
c
702 0 (-36 35 -38 37 -13 3) (-402:403:-532:533:-531) (-402:403:-432:433:-431)
    imp:n=1 fill=100 (-4.05003 -3.85445 0) $ Core
703 1 9.9928E-02 (36:-35:38:-37) (-402:403:-532:533:-531)
    (-402:403:-432:433:-431) 3 -13 -71 imp:n=1 $ Tank Water
c
c --- Model Boundary -----
901 0 -3:13:71 imp:n=0
c
c Surface Cards *****
c --- Primary Model Dimensions -----

```

Fundamental - FUND

NRAD-FUND-RESR-001
CRIT-REAC-COEF

```

c ----- Horizontal Planes -----
3   pz   42.54876 $ Bottom Model Boundary
9   pz   62.46876 $ Bottom Assembly Boundary
10  pz   128.19127 $ Top Assembly Boundary
13  pz   151.28627 $ Top Model Boundary
c
c ----- Vertical Planes -----
31  px   -4.05003 $ West Assembly Boundary
32  px    4.05003 $ East Assembly Boundary
33  py   -3.85445 $ South Assembly Boundary
34  py    3.85445 $ North Assembly Boundary
35  px  -24.31415 $ West Edge of Grid Plate
36  px   24.31415 $ East Edge of Grid Plate
37  py  -23.33625 $ South Edge of Grid Plate
38  py   23.33625 $ North Edge of Grid Plate
c
c ----- Radii -----
71  cz    45      $ Radial Model Boundary
c
c --- Fuel Rods -----
c ----- Horizontal Planes -----
102 pz   67.54876 $ Bottom of Clad Tube
103 pz   68.81876 $ Bottom End Fitting/Bottom Graphite Reflector Interface
104 pz   77.50556 $ Bottom Graphite Reflector/Moly Disc Interface
105 pz   77.584935 $ Moly Disc/Fuel Rods Interface
106 pz  115.604935 $ Fuel Rods/Top Graphite Reflector Interface
107 pz  124.291735 $ Top Graphite Reflector/Void Gap Interface
108 pz  125.01627 $ Void Gap/Top End Fitting Interface
109 pz  126.28627 $ Top of Clad Tube
c
c ----- Vertical Planes -----
131 px   -1.9431  $ West Fuel Boundary
132 px    1.9431  $ East Fuel Boundary
133 py   -1.9431  $ South Fuel Boundary
134 py    1.9431  $ North Fuel Boundary
c
c ----- Radii -----
152 cz   1.63957 $ Axial Graphite Reflectors
153 cz   1.73482 $ Moly Poison Disc
154 cz   0.28575 $ Zirconium Rods
155 cz   0.3175  $ Fuel Rod ID
156 cz   1.74025 $ Fuel Rod OD
157 cz   1.7447  $ Cladding Inner Surface
158 cz   1.7955  $ Cladding Outer Surface
c
c --- Control Rods -----
c ----- Horizontal Planes -----
231 pz   76.12126 $ Bottom of Control Rod Clad
232 pz   77.70876 $ Clad/B4C Rod Interface
233 pz  115.80876 $ B4C Rod/Void Interface
235 pz  133.58876 $ Void/Clad Interface
236 pz  135.55726 $ Top of Control Rod Clad
c
c ----- Radii -----
271 cz   1.50749 $ B4C Outer Surface
275 cz   1.51638 $ Cladding Inner Surface
276 cz   1.5875  $ Cladding Outer Surface
c
c --- Graphite Reflector Assemblies -----
c ----- Vertical Planes -----
331 px   -3.683   $ West Graphite Surface
332 px    3.683   $ East Graphite Surface
333 py   -3.683   $ South Graphite Surface
334 py    3.683   $ North Graphite Surface
335 p   -3.683   2.7305 1 -3.683  2.7305 -1 -2.7305  3.683 1 $ NW Chamfer
336 p    3.683   2.7305 1  3.683  2.7305 -1  2.7305  3.683 1 $ NE Chamfer
337 p   -3.683  -2.7305 1 -3.683  -2.7305 -1 -2.7305 -3.683 1 $ SW Chamfer
338 p    3.683  -2.7305 1  3.683  -2.7305 -1  2.7305 -3.683 1 $ SE Chamfer
c
c --- Beam Lines -----
c ----- Horizontal Planes -----
402 pz   88.33993 $ Bottom Surface of Beam Filter Tubes
403 pz  104.84993 $ Top Surface of Beam Filter Tubes
c
c ----- Vertical Planes -----
c ----- East Beam Assembly -----

```

Fundamental - FUND

NRAD-FUND-RESR-001
CRIT-REAC-COEF

```

431 px 17.92069 $ Core Face of Beam Filter Tube
432 py -6.985 $ South Surface of Beam Filter Tube
433 py 6.985 $ North Surface of Beam Filter Tube
434 px 51.57597 $ Back End of Beam Filter Tube
c
c ----- North Beam Assembly -----
531 py 17.33395 $ Core Face of West Beam Filter Tube
532 px -6.985 $ East Surface of West Beam Filter Tube
533 px 6.985 $ West Surface of West Beam Filter Tube
534 py 52.54498 $ Back End of Beam Filter Tube
c

c Data Cards *****
c
c *** Material Cards *****
c --- Water -----
m1 1001.70c 6.6611E-02 1002.70c 7.6612E-06 8016.70c 3.3297E-02
    8017.70c 1.2658E-05
c Total 9.9928E-02
mt1 lwtr.10t hwtr.10t
c
c --- Fuel Rods (Non-Fuel Components) -----
c ----- Axial Graphite Reflectors -----
m2 6000.70c 8.6734E-02
c Total 8.6734E-02
mt2 grph.10t
c
c ----- Moly Poison Disc -----
m3 42092.70c 9.5169E-03 42094.70c 5.9320E-03 42095.70c 1.0210E-02
    42096.70c 1.0697E-02 42097.70c 6.1244E-03 42098.70c 1.5475E-02
    42100.70c 6.1757E-03
c Total 6.4130E-02
c
c ----- Zr Rod -----
m4 40090.70c 2.2070E-02 40091.70c 4.8130E-03 40092.70c 7.3568E-03
    40094.70c 7.4555E-03 40096.70c 1.2011E-03
c Total 4.2897E-02
c
c ----- SS 304 Cladding and End Fittings -----
m5 6000.70c 1.6044E-04 14028.70c 6.3283E-04 14029.70c 3.2134E-05
    14030.70c 2.1183E-05 15031.70c 4.0441E-05 16032.70c 3.1374E-06
    16033.70c 2.5117E-08 16034.70c 1.4178E-07 16036.70c 6.6099E-10
    24050.70c 7.6491E-04 24052.70c 1.4751E-02 24053.70c 1.6726E-03
    24054.70c 4.1634E-04 25055.70c 8.7693E-04 26054.70c 3.4644E-03
    26056.70c 5.4383E-02 26057.70c 1.2559E-03 26058.70c 1.6714E-04
    28058.70c 5.5882E-03 28060.70c 2.1526E-03 28061.70c 9.3571E-05
    28062.70c 2.9834E-04 28064.70c 7.5980E-05
c Total 8.6851E-02
mt5 fe56.12t
c
c --- Control Rods -----
c ----- B4C Absorber -----
m6 5010.70c 2.1515E-02 5011.70c 8.6601E-02 6000.70c 2.7029E-02
c Total 1.3514E-01
mt6 grph.10t
c
c ----- Al 6061 Cladding and End Fittings -----
m7 13027.70c 5.8593E-02
c Total 5.8593E-02
mt7 al27.12t
c
c --- Graphite Reflector Assemblies -----
c ----- Graphite Reflectors -----
m8 6000.70c 7.8692E-02
c Total 7.8692E-02
mt8 grph.10t
c
c ----- 60-Rod-Average UErZrH Fuel Rod Composition -----
m9 92234.70c 9.9323E-06 92235.70c 1.0844E-03 92236.70c 1.2036E-05
    92238.70c 4.3326E-03 5010.70c 7.6277E-08 5011.70c 3.0702E-07
    1001.70c 5.0608E-02 1002.70c 5.8206E-06 6000.70c 1.0781E-03
    40090.70c 1.6481E-02 40091.70c 3.5940E-03 40092.70c 5.4936E-03
    40094.70c 5.5672E-03 40096.70c 8.9691E-04 68162.70c 3.2517E-07
    68164.70c 3.7395E-06 68166.70c 7.8064E-05 68167.70c 5.3258E-05
    68168.70c 6.2200E-05 68170.70c 3.4677E-05 72174.70c 1.3203E-09
    72176.70c 4.3403E-08 72177.70c 1.5348E-07 72178.70c 2.2510E-07

```

Fundamental - FUND

NRAD-FUND-RESR-001
CRIT-REAC-COEF

```
72179.70c 1.1239E-07 72180.70c 2.8947E-07
c Total 8.9397E-02
mt9 h/zr.10t zr/h.10t
c
c
c *** Control Cards *****
mode n
kcode 100000 1 50 1550
ksrc -1.9431 -1.9431 96.6 1.9431 1.9431 96.6
      -5.8293 5.8293 96.6 5.8293 -5.8293 96.6
      -9.7155 -9.7155 96.6 9.7155 9.7155 96.6
      -13.6017 13.6017 96.6 13.6017 -13.6017 96.6
      -13.6017 0.0 96.6 13.6017 0.0 96.6
      0.0 13.6017 96.6 0.0 -13.6017 96.6
print
kopts blocksize=10 kinetics=yes precursor=yes
c
```

Fundamental - FUND

NRAD-FUND-RESR-001
CRIT-REAC-COEF*KENO Input Deck for the 56-fuel-element initial core configuration (Case 1):*

```

'Input generated by GeeWiz SCALE 6.1 Compiled on Mon Jun  6 11:04:33 2011
=csas6
fresh-core reload of the nrad reactor with u(20)-er-zr-h fuel (simple)
v7-238
read composition
c-graphite  1 0 0.078692 294  end
h-zrh2      3 0 0.05062 294  end
b           3 0 3.8328e-07 294
                    5010 19.9
                    5011 80.1  end
c           3 0 0.0010781 294  end
zr-zrh2     3 0 0.032036 294  end
er          3 0 0.00023226 294
                    68162 0.14
                    68164 1.61
                    68166 33.61
                    68167 22.93
                    68168 26.78
                    68170 14.93  end
hafnium     3 0 8.2525e-07 294
                    72174 0.16
                    72176 5.26
                    72177 18.6
                    72178 27.28
                    72179 13.62
                    72180 35.08  end
u-234       3 0 9.9283e-06 294  end
u-235       3 0 0.0010836 294  end
u-236       3 0 1.2032e-05 294  end
u-238       3 0 0.0043312 294  end
c-graphite  4 0 0.086734 294  end
mo          5 0 0.06413 294
                    42092 14.84
                    42094 9.25
                    42095 15.92
                    42096 16.68
                    42097 9.55
                    42098 24.13
                    42100 9.63  end
zirconium   6 0 0.042897 294
                    40090 51.45
                    40091 11.22
                    40092 17.15
                    40094 17.38
                    40096 2.8  end
c           7 0 0.00016044 294  end
si          7 0 0.00068614 294
                    14028 92.2297
                    14029 4.6832
                    14030 3.0871  end
p           7 0 4.0441e-05 294  end
s           7 0 3.3049e-06 294
                    16032 94.93
                    16033 0.76
                    16034 4.29
                    16036 0.02  end
cr          7 0 0.017604 294
                    24050 4.345
                    24052 83.789
                    24053 9.501
                    24054 2.365  end
mn          7 0 0.00087693 294  end
fe          7 0 0.059271 294
                    26054 5.845
                    26056 91.754
                    26057 2.119
                    26058 0.282  end
ni          7 0 0.0082087 294
                    28058 68.0769
                    28060 26.2231
                    28061 1.1399
                    28062 3.6345
                    28064 0.9256  end

```

Fundamental - FUND

NRAD-FUND-RESR-001
CRIT-REAC-COEF

```

b-10      8 0 0.021515 294 end
b-11      8 0 0.086601 294 end
c-graphite 8 0 0.027029 294 end
al        9 0 0.058953 294 end
h         10 0 0.066641 294 end
o         10 0 0.03332 294 end
end composition
read celldata
  latticecell squarepitch fuelr=1.74025 3 gapr=1.7447 0 cladr=1.7955 7 hpitch=1.97612 10 end
end celldata
read parameter
  gen=1550
  npg=100000
  nsk=50
  htm=yes
end parameter
read geometry
unit 1
com="graphite reflector block"
cuboid 1  3.683  -3.683  3.683  -3.683  65.72251  0
cuboid 2  4.535029 -4.535029 4.535029 -4.535029 65.72251  0 rotate a1=45 a2=0 a3=0
cuboid 3  4.05003 -4.05003 3.85445 -3.85445 88.81751 -19.92
media 1 1 1 2
media 10 1 -1 2
media 10 1 -2 3
boundary 3
unit 2
com="fuel rod"
cylinder 1  1.7955  63.81751  5.08
cylinder 2  1.7447  63.81751  5.08
cylinder 3  1.63957  15.0368  6.35
cylinder 4  1.73482  15.11618  15.0368
cylinder 5  0.28575  53.13618  15.11618
cylinder 6  1.74025  53.13618  15.11618
cylinder 7  0.316  53.13618  15.11618
cylinder 8  1.63957  61.82298  53.13618
cylinder 9  1.7447  6.35  5.08
cylinder 10  1.7447  62.54751  61.82298
cylinder 11  1.7447  63.81751  62.54751
cuboid 12  1.9431 -1.9431 1.9431 -1.9431 88.81751 -19.92
media 7 1 1 -2
media 7 1 9
media 4 1 3
media 6 1 5
media 0 1 -5 7
media 3 1 6 -7
media 4 1 8
media 7 1 11
media 0 1 2 -3 -4 -6 -8 -9 -11
media 10 1 -1 12
media 5 1 4
boundary 12
unit 6
com="all fuel rods"
cuboid 1  4.05003 -4.05003 3.85445 -3.85445 88.81751 -19.92
array 1 1 place 2 2 1 -1.9431 -1.9431 0
boundary 1
unit 7
com="water"
cuboid 1  4.05003 -4.05003 3.85445 -3.85445 88.81751 -19.92
media 10 1 1
boundary 1
global unit 8
com="tank"
cylinder 1  45 88.81751 -19.92
cuboid 2  45 17.92069 6.985 -6.985 42.38117 25.78118
cuboid 4  6.985 -6.985 45 17.33395 42.38117 25.87118
array 2 1 -2 -4 place 6 6 1 -4.05003 -3.85445 0
media 0 1 1 2
media 0 1 4 1
boundary 1
unit 3
com="water smaller unit"
cuboid 1  1.9431 -1.9431 1.9431 -1.9431 88.81751 -19.92
media 10 1 1
boundary 1

```

Fundamental - FUND

NRAD-FUND-RESR-001
CRIT-REAC-COEF

```

unit 9
com="shim"
cylinder 1 1.51638 53.34 51.7525
cylinder 2 1.50749 91.44 53.34
cylinder 3 1.51638 111.1885 109.22
cylinder 4 1.51638 111.1885 51.7525
cylinder 5 1.5875 111.1885 51.7525
cuboid 6 1.9431 -1.9431 1.9431 -1.9431 88.81751 -19.92
media 9 1 5 -4
media 9 1 1
media 8 1 2
media 9 1 3
media 0 1 4 -1 -2 -3
media 10 1 6 -5
boundary 6
unit 10
com="reg"
cylinder 1 1.51638 44.7675 43.18
cylinder 2 1.50749 82.8675 44.7675
cylinder 3 1.51638 102.616 100.6475
cylinder 4 1.51638 102.616 43.18
cylinder 5 1.5875 102.616 43.18
cuboid 6 1.9431 -1.9431 1.9431 -1.9431 88.81751 -19.92
media 9 1 5 -4
media 9 1 1
media 8 1 2
media 9 1 3
media 0 1 4 -1 -2 -3
media 10 1 6 -5
boundary 6
unit 11
com="shim 2 cluster"
cuboid 1 4.05003 -4.05003 3.85445 -3.85445 88.81751 -19.92
array 3 1 place 2 2 1 -1.9431 -1.9431 0
boundary 1
unit 12
com="shim 1 cluster"
cuboid 1 4.05003 -4.05003 3.85445 -3.85445 88.81751 -19.92
array 4 1 place 2 2 1 -1.9431 -1.9431 0
boundary 1
unit 13
com="reg rod cluster"
cuboid 1 4.05003 -4.05003 3.85445 -3.85445 88.81751 -19.92
array 5 1 place 2 2 1 -1.9431 -1.9431 0
boundary 1
unit 14
com="three rod cluster"
cuboid 1 4.05003 -4.05003 3.85445 -3.85445 88.81751 -19.92
array 6 1 place 2 2 1 -1.9431 -1.9431 0
boundary 1
end geometry
read array
ara=1 nux=4 nuy=4 nuz=1 typ=square
com=''
fill
  3 3 3 3
  3 2 2 3
  3 2 2 3
  3 3 3 3 end fill
ara=2 nux=12 nuy=12 nuz=1 typ=square gbl=2
com=''
fill
  7 7 7 7 7 7 7 7 7 7 7 7
  7 7 7 7 7 7 7 7 7 7 7 7
  7 7 7 7 7 7 7 7 7 7 7 7
  7 7 7 7 1 1 1 1 7 7 7 7
  7 7 7 7 1 6 6 13 6 1 7 7 7
  7 7 7 7 1 12 6 6 6 7 7 7 7
  7 7 7 7 1 11 6 14 6 7 7 7 7
  7 7 7 7 1 6 6 6 1 1 7 7 7
  7 7 7 7 7 1 7 7 7 7 7 7 7
  7 7 7 7 7 7 7 7 7 7 7 7
  7 7 7 7 7 7 7 7 7 7 7 7
  7 7 7 7 7 7 7 7 7 7 7 7 end fill
ara=3 nux=4 nuy=4 nuz=1 typ=square
com='shim rod 2'

```

```
fill
  3  3  3  3
  3  2  2  3
  3  2  9  3
  3  3  3  3 end fill
ara=4 nux=4 nuy=4 nuz=1 typ=square
com=''
fill
  3  3  3  3
  3  2  9  3
  3  2  2  3
  3  3  3  3 end fill
ara=5 nux=4 nuy=4 nuz=1 typ=square
com='reg rod cluster'
fill
  3  3  3  3
  3  2  2  3
  3  2  10  3
  3  3  3  3 end fill
ara=6 nux=4 nuy=4 nuz=1 typ=square
com='three rod cluster'
fill
  3  3  3  3
  3  3  2  3
  3  2  2  3
  3  3  3  3 end fill
end array
read plot
scr=yes
ttl='x-y plot'
pic=mixtures
xul=-45
yul=45
zul=34.44875
xlr=45
ylr=-45
zlr=34.44875
nax=800
clr=1 255 0 0
  3 0 229 238
  4 0 238 0
  5 205 205 0
  6 238 0 0
  7 145 44 238
  8 150 150 150
  9 240 200 220
 10 0 191 255
end color
uax=1 vdn=-1
end
end plot
end data
end
```

Fundamental - FUND

NRAD-FUND-RESR-001
CRIT-REAC-COEF*KENO Input Deck for the 60-fuel-element operational core configuration (Case 2):*

'Input generated by GeeWiz SCALE 6.1 Compiled on Mon Jun 6 11:04:33 2011
=csas6

fresh-core reload of the nrad reactor with u(20)-er-zr-h fuel (simple)

ce_v7_endf

read composition

c-graphite	1	0	0.078692	294	end	
h-zrh2	3	0	0.050614	294	end	
b	3	0	3.833e-07	294		
						5010 19.9
						5011 80.1 end
c	3	0	0.0010781	294	end	
zr-zrh2	3	0	0.032032	294	end	
er	3	0	0.00023226	294		
						68162 0.14
						68164 1.61
						68166 33.61
						68167 22.93
						68168 26.78
						68170 14.93 end
hafnium	3	0	8.2516e-07	294		
						72174 0.16
						72176 5.26
						72177 18.6
						72178 27.28
						72179 13.62
						72180 35.08 end
u-234	3	0	9.9323e-06	294	end	
u-235	3	0	0.0010844	294	end	
u-236	3	0	1.2036e-05	294	end	
u-238	3	0	0.0043326	294	end	
c-graphite	4	0	0.086734	294	end	
mo	5	0	0.06413	294		
						42092 14.84
						42094 9.25
						42095 15.92
						42096 16.68
						42097 9.55
						42098 24.13
						42100 9.63 end
zirconium	6	0	0.042897	294		
						40090 51.45
						40091 11.22
						40092 17.15
						40094 17.38
						40096 2.8 end
c	7	0	0.00016044	294	end	
si	7	0	0.00068614	294		
						14028 92.2297
						14029 4.6832
						14030 3.0871 end
p	7	0	4.0441e-05	294	end	
s	7	0	3.3049e-06	294		
						16032 94.93
						16033 0.76
						16034 4.29
						16036 0.02 end
cr	7	0	0.017604	294		
						24050 4.345
						24052 83.789
						24053 9.501
						24054 2.365 end
mn	7	0	0.00087693	294	end	
fe	7	0	0.059271	294		
						26054 5.845
						26056 91.754
						26057 2.119
						26058 0.282 end
ni	7	0	0.0082087	294		
						28058 68.0769
						28060 26.2231
						28061 1.1399
						28062 3.6345
						28064 0.9256 end

Fundamental - FUND

NRAD-FUND-RESR-001
CRIT-REAC-COEF

```

b-10      8 0 0.021515 294 end
b-11      8 0 0.086601 294 end
c-graphite 8 0 0.027029 294 end
al        9 0 0.058953 294 end
h         10 0 0.066619 294 end
o         10 0 0.033309 294 end
end composition
read parameter
gen=1550
npg=100000
nsk=50
htm=yes
end parameter
read geometry
unit 1
com="graphite reflector block"
cuboid 1  3.683 -3.683  3.683 -3.683 65.72251 0
cuboid 2  4.535029 -4.535029 4.535029 -4.535029 65.72251 0 rotate a1=45 a2=0 a3=0
cuboid 3  4.05003 -4.05003 3.85445 -3.85445 88.81751 -19.92
media 1 1 1 2
media 10 1 -1 2
media 10 1 -2 3
boundary 3
unit 2
com="fuel rod"
cylinder 1  1.7955 63.81751 5.08
cylinder 2  1.7447 63.81751 5.08
cylinder 3  1.63957 15.0368 6.35
cylinder 4  1.73482 15.11618 15.0368
cylinder 5  0.28575 53.13618 15.11618
cylinder 6  1.74025 53.13618 15.11618
cylinder 7  0.316 53.13618 15.11618
cylinder 8  1.63957 61.82298 53.13618
cylinder 9  1.7447 6.35 5.08
cylinder 10  1.7447 62.54751 61.82298
cylinder 11  1.7447 63.81751 62.54751
cuboid 12  1.9431 -1.9431 1.9431 -1.9431 88.81751 -19.92
media 7 1 1 -2
media 7 1 9
media 4 1 3
media 6 1 5
media 0 1 -5 7
media 3 1 6 -7
media 4 1 8
media 7 1 11
media 0 1 2 -3 -4 -6 -8 -9 -11
media 10 1 -1 12
media 5 1 4
boundary 12
unit 6
com="all fuel rods"
cuboid 1  4.05003 -4.05003 3.85445 -3.85445 88.81751 -19.92
array 1 1 place 2 2 1 -1.9431 -1.9431 0
boundary 1
unit 7
com="water"
cuboid 1  4.05003 -4.05003 3.85445 -3.85445 88.81751 -19.92
media 10 1 1
boundary 1
global unit 8
com="tank"
cylinder 1  45 88.81751 -19.92
cuboid 2  45 17.92069 6.985 -6.985 42.38117 25.78118
cuboid 4  6.985 -6.985 45 17.33395 42.38117 25.87118
array 2 1 -2 -4 place 6 6 1 -4.05003 -3.85445 0
media 0 1 1 2
media 0 1 4 1
boundary 1
unit 3
com="water smaller unit"
cuboid 1  1.9431 -1.9431 1.9431 -1.9431 88.81751 -19.92
media 10 1 1
boundary 1
unit 9
com="shim"
cylinder 1  1.51638 53.34 51.7525

```

Fundamental - FUND

NRAD-FUND-RESR-001
CRIT-REAC-COEF

```

cylinder 2 1.50749 91.44 53.34
cylinder 3 1.51638 111.1885 109.22
cylinder 4 1.51638 111.1885 51.7525
cylinder 5 1.5875 111.1885 51.7525
cuboid 6 1.9431 -1.9431 1.9431 -1.9431 88.81751 -19.92
media 9 1 5 -4
media 9 1 1
media 8 1 2
media 9 1 3
media 0 1 4 -1 -2 -3
media 10 1 6 -5
boundary 6
unit 10
com="reg"
cylinder 1 1.51638 35.6616 34.0741
cylinder 2 1.50749 73.7616 35.6616
cylinder 3 1.51638 93.5101 91.5416
cylinder 4 1.51638 93.5101 34.0741
cylinder 5 1.5875 93.5101 34.0741
cuboid 6 1.9431 -1.9431 1.9431 -1.9431 88.81751 -19.92
media 9 1 5 -4
media 9 1 1
media 8 1 2
media 9 1 3
media 0 1 4 -1 -2 -3
media 10 1 6 -5
boundary 6
unit 11
com="shim 2 cluster"
cuboid 1 4.05003 -4.05003 3.85445 -3.85445 88.81751 -19.92
array 3 1 place 2 2 1 -1.9431 -1.9431 0
boundary 1
unit 12
com="shim 1 cluster"
cuboid 1 4.05003 -4.05003 3.85445 -3.85445 88.81751 -19.92
array 4 1 place 2 2 1 -1.9431 -1.9431 0
boundary 1
unit 13
com="reg rod cluster"
cuboid 1 4.05003 -4.05003 3.85445 -3.85445 88.81751 -19.92
array 5 1 place 2 2 1 -1.9431 -1.9431 0
boundary 1
unit 14
com="three rod cluster"
cuboid 1 4.05003 -4.05003 3.85445 -3.85445 88.81751 -19.92
array 6 1 place 2 2 1 -1.9431 -1.9431 0
boundary 1
end geometry
read array
ara=1 nux=4 nuy=4 nuz=1 typ=square
com=''
fill
  3 3 3 3
  3 2 2 3
  3 2 2 3
  3 3 3 3 end fill
ara=2 nux=12 nuy=12 nuz=1 typ=square gbl=2
com=''
fill
  7 7 7 7 7 7 7 7 7 7 7 7
  7 7 7 7 7 7 7 7 7 7 7 7
  7 7 7 7 7 7 7 7 7 7 7 7
  7 7 7 7 1 1 1 1 7 7 7 7
  7 7 7 7 1 6 6 13 6 1 7 7 7
  7 7 7 7 1 12 6 6 6 7 7 7 7
  7 7 7 7 1 11 6 14 6 7 7 7 7
  7 7 7 7 1 6 6 6 6 1 7 7 7
  7 7 7 7 7 1 7 7 1 7 7 7 7
  7 7 7 7 7 7 7 7 7 7 7 7
  7 7 7 7 7 7 7 7 7 7 7 7
  7 7 7 7 7 7 7 7 7 7 7 7 end fill
ara=3 nux=4 nuy=4 nuz=1 typ=square
com='shim rod 2'
fill
  3 3 3 3
  3 2 2 3

```

```
      3   2   9   3
      3   3   3   3 end fill
ara=4 nux=4 nuy=4 nuz=1 typ=square
com=''
fill
      3   3   3   3
      3   2   9   3
      3   2   2   3
      3   3   3   3 end fill
ara=5 nux=4 nuy=4 nuz=1 typ=square
com='reg rod cluster'
fill
      3   3   3   3
      3   2   2   3
      3   2  10   3
      3   3   3   3 end fill
ara=6 nux=4 nuy=4 nuz=1 typ=square
com='three rod cluster'
fill
      3   3   3   3
      3   3   2   3
      3   2   2   3
      3   3   3   3 end fill
end array
read plot
scr=yes
ttl='x-y plot'
pic=mixtures
xul=-45
yul=45
zul=34.44875
xlr=45
ylr=-45
zlr=34.44875
nax=800
clr=1 255 0 0
      3 0 229 238
      4 0 238 0
      5 205 205 0
      6 238 0 0
      7 145 44 238
      8 150 150 150
      9 240 200 220
     10 0 191 255
end color
uax=1 vdn=-1
end
end plot
end data
end
```

Fundamental - FUND

NRAD-FUND-RESR-001
CRIT-REAC-COEF*SERPENT Input Deck for the 56-fuel-element initial core configuration (Case 1):*

```

% !!! NRAD Reactor 56-Fuel-Element Core !!!!!!!!!!!!!!!!!!!!!!!!!!!!!!!!!!!!!!!!!!!!!!!
% John Darrell Bess - Idaho National Laboratory
% Last Updated: March 1, 2012
% !!!!!!!!!!!!!!!!!!!!!!!!!!!!!!!!!!!!!!!!!!!!!!!!!!!!!!!!!!!!!!!!!!!!!!!!!!!!!!!!!!!!!

set title "NRAD 56"

% *** Cell Cards ****
% cell <name> <u0> <mat> <surf #>
% <name> cell name
% <u0> universe number of cell
% <mat> cell material (if cell is empty, material name is set to "void")
%                               (if cell is geometry boundary, it is set to "outside")
%                               (if cell is filled, it is set to "fill" followed by universe #)
% <surf #> boundary surfaces

% universe transformation (not needed in lattices)
% trans <u> <x> <y> <z>
% <u> universe number
% <x,y,z> x,y,z-coordinate of new origin

% lattice descriptions
% lat <u0> <type> <x0> <y0> <nx> <ny> <p>
% <u0> universe number of lattice
% <type> lattice type (1) square (2) x-type hexagonal (2) y-type hexagonal
%                               (4) circular (6,7,8) infinite of types 1,2,3 (9) vertical stack
% <x0/y0> x-/y-coordinate of the lattice origin
% <nx/ny> number of lattice elements in the x-/y-direction
% <p> lattice pitch

% --- Assemblies -----
% ----- Graphite Reflector -----
cell block 200 refl 9 -10 -331 % Graphite Block
cell h2ob1 200 h2o 9 -10 331 % Water Around Assembly
cell h2ob2 200 h2o -9 % Water Below Assembly
cell h2ob3 200 h2o 10 % Water Above Assembly

% ----- Fuel Rod -----
cell bfcap 301 ss304 102 -103 -157 % Bottom End Cap
cell baxgr 301 axgr 103 -104 -152 % Bottom Graphite Reflector
cell fgap1 301 void 103 -104 152 -157 % Gap Around Bottom Graphite Reflector
cell pdisc 301 moly 104 -105 -153 % Moly Poison Disc
cell fgap2 301 void 104 -105 153 -157 % Gap Around Moly Poison Disc
cell zrrrod 301 zirc 105 -106 -154 % Zirconium Rod
cell fgap3 301 void 105 -106 154 -155 % Zr/Fuel Gap
cell fuel 301 fuel 105 -106 155 -156 % Fuel Rod
cell fgap4 301 void 105 -106 156 -157 % Gap Around Fuel Rod
cell taxgr 301 axgr 106 -107 -152 % Top Graphite Reflector
cell fgap5 301 void 106 -107 152 -157 % Gap Around Top Graphite Reflector
cell fgap6 301 void 107 -108 -157 % Gap Above Top Graphite Reflector
cell tfcap 301 ss304 108 -109 -157 % Top End Cap
cell fclad 301 ss304 102 -109 157 -158 % Cladding
cell h2of1 301 h2o 102 -109 158 % Water Around Fuel
cell h2of2 301 h2o -102 % Water Below Fuel
cell h2of3 301 h2o 109 % Water Above Fuel

% ----- Control Rods -----
cell bacap 401 alum 231 -232 -275 % Bottom End Fitting
cell cr 401 b4c 232 -233 -271 % Absorber Rod
cell agap1 401 void 232 -233 271 -275 % Gap Around Absorber Rod
cell agap2 401 void 233 -235 -275 % Gap Above Absorber Rod
cell tacap 401 alum 235 -236 -275 % Top End Fitting
cell aclad 401 alum 231 -236 275 -276 % Cladding
cell h2oa1 401 h2o 231 -236 276 % Water Around Control Rod
cell h2oa2 401 h2o -231 % Water Below Control Rod
cell h2oa3 401 h2o 236 % Water Above Control Rod

cell shim1 402 fill 401 -1 % Shim 1 Control Rod
trans 402 0.0 0.0 38.1
cell shim2 403 fill 401 -1 % Shim 2 Control Rod
trans 403 0.0 0.0 38.1
cell reg 404 fill 401 -1 % Reg Control Rod
trans 404 0.0 0.0 29.5275

```

Fundamental - FUND

NRAD-FUND-RESR-001
CRIT-REAC-COEF

```

% * Control Rods are fully inserted when the translated values 0 0 0 *
% * Control Rods are fully withdrawn when the translated values are 0 0 38.1), *
% * which corresponds to 1000 units withdrawn *

% ----- 4-Rod Fuel Cluster -----
cell wat1 999 h2o -1 % water
lat 101 1 0.0 0.0 4 4 3.8862
999 999 999 999
999 301 301 999
999 301 301 999
999 999 999 999
cell 4rods 300 fill 101 -31 % Fuel Bundle
cell h2on1 300 h2o 31 % Water Around Bundle

% ----- Position D-2 : Shim Rod 1 Control Cluster -----
lat 102 1 0.0 0.0 4 4 3.8862
999 999 999 999
999 301 402 999
999 301 301 999
999 999 999 999
cell 3shml 400 fill 102 -31 % Fuel Bundle
cell h2on2 400 h2o 31 % Water Around Bundle

% ----- Position C-2 : Shim Rod 2 Control Cluster -----
lat 103 1 0.0 0.0 4 4 3.8862
999 999 999 999
999 301 301 999
999 301 403 999
999 999 999 999
cell 3shml 500 fill 103 -31 % Fuel Bundle
cell h2on3 500 h2o 31 % Water Around Bundle

% ----- Position E-4 : Regulating Rod Control Cluster -----
lat 104 1 0.0 0.0 4 4 3.8862
999 999 999 999
999 301 301 999
999 301 404 999
999 999 999 999
cell 3reg 600 fill 104 -31 % Fuel Bundle
cell h2on4 600 h2o 31 % Water Around Bundle

% ----- Position C-4 : Sample Irradiation Cluster -----
lat 105 1 0.0 0.0 4 4 3.8862
999 999 999 999
999 999 301 999
999 301 301 999
999 999 999 999
cell 3irr 700 fill 105 -31 % Fuel Bundle
cell h2on5 700 h2o 31 % Water Around Bundle

% --- Beam Lines -----
cell ebeam 0 void -402 -71 % East Beam Filter Tube
cell nbeam 0 void -403 -71 % North Beam Filter Tube

% --- NRAD Reactor -----
% ----- Assembly Rows -----
cell wat2 998 h2o -1 % water
lat 901 1 0.0 0.0 8 9 8.10006
998 998 998 998 998 998 998 998
998 998 998 998 998 998 998 998
998 998 998 998 998 998 998 998
998 998 998 998 998 998 998 998
998 998 200 998 998 998 998 998
998 998 998 998 998 998 998 998
998 998 998 998 998 998 998 998
998 998 998 998 998 998 998 998
998 998 998 998 998 998 998 998
cell rowA 911 fill 901 -35 % Row A
cell h2oA 911 h2o 35
trans 911 0.0 19.27225 0.0
cell rowA2 0 fill 911 -41 403 % Row A

lat 902 1 0.0 0.0 8 9 8.10006
998 998 998 998 998 998 998 998
998 998 998 998 998 998 998 998
998 998 998 998 998 998 998 998

```

Fundamental - FUND

NRAD-FUND-RESR-001
CRIT-REAC-COEF

```
998 998 998 998 998 998 998 998
998 200 300 300 300 200 200 998
998 998 998 998 998 998 998 998
998 998 998 998 998 998 998 998
998 998 998 998 998 998 998 998
998 998 998 998 998 998 998 998
cell rowB 912 fill 902 -35 % Row B
cell h2oB 912 h2o 35
trans 912 0.0 11.56335 0.0
cell rowB2 0 fill 912 -42 % Row B

lat 903 1 0.0 0.0 8 9 8.10006
998 998 998 998 998 998 998 998
998 998 998 998 998 998 998 998
998 998 998 998 998 998 998 998
998 998 998 998 998 998 998 998
998 200 500 300 700 300 998 998
998 998 998 998 998 998 998 998
998 998 998 998 998 998 998 998
998 998 998 998 998 998 998 998
998 998 998 998 998 998 998 998
cell rowC 913 fill 903 -35 % Row C
cell h2oC 913 h2o 35
trans 913 0.0 3.85445 0.0
cell rowC2 0 fill 913 -43 402 % Row C

lat 904 1 0.0 0.0 8 9 8.10006
998 998 998 998 998 998 998 998
998 998 998 998 998 998 998 998
998 998 998 998 998 998 998 998
998 998 998 998 998 998 998 998
998 200 400 300 300 300 998 998
998 998 998 998 998 998 998 998
998 998 998 998 998 998 998 998
998 998 998 998 998 998 998 998
998 998 998 998 998 998 998 998
cell rowD 914 fill 904 -35 % Row D
cell h2oD 914 h2o 35
trans 914 0.0 -3.85445 0.0
cell rowD2 0 fill 914 -44 402 % Row D

lat 905 1 0.0 0.0 8 9 8.10006
998 998 998 998 998 998 998 998
998 998 998 998 998 998 998 998
998 998 998 998 998 998 998 998
998 998 998 998 998 998 998 998
998 200 300 300 600 300 200 998
998 998 998 998 998 998 998 998
998 998 998 998 998 998 998 998
998 998 998 998 998 998 998 998
998 998 998 998 998 998 998 998
cell rowE 915 fill 905 -35 % Row E
cell h2oE 915 h2o 35
trans 915 0.0 -11.56335 0.0
cell rowE2 0 fill 915 -45 % Row E

lat 906 1 0.0 0.0 8 9 8.10006
998 998 998 998 998 998 998 998
998 998 998 998 998 998 998 998
998 998 998 998 998 998 998 998
998 998 998 998 998 998 998 998
998 998 200 200 200 200 998 998
998 998 998 998 998 998 998 998
998 998 998 998 998 998 998 998
998 998 998 998 998 998 998 998
998 998 998 998 998 998 998 998
cell rowF 916 fill 906 -35 % Row F
cell h2oF 916 h2o 35
trans 916 0.0 -19.27225 0.0
cell rowF2 0 fill 916 -46 % Row F

cell wat3 0 h2o 41 42 43 44 45 46 -35 % Water
cell core 0 h2o 402 403 35 -71 % Benchmark Model

cell void 0 outside 71
```

Fundamental - FUND

NRAD-FUND-RESR-001
CRIT-REAC-COEF

```

% *** Surface Cards *****
% surf <id> <type> <param #>
% <id> surface identifier
% <type> surface type
% <param #> surface parameters

% --- Primary Model Dimensions -----
surf 1 inf
% ----- Vertical Planes -----
surf 31 cuboid -4.05003 4.05003 -3.85445 3.85445 42.54786 151.28627 % Assembly Positions
surf 35 cuboid -24.31415 24.31415 -23.33625 23.33625 42.54786 151.28627 % Core Boundary
surf 41 cuboid -24.31415 24.31415 15.4178 23.33625 42.54786 151.28627 % Row A
surf 42 cuboid -24.31415 24.31415 7.7089 15.4178 42.54786 151.28627 % Row B
surf 43 cuboid -24.31415 24.31415 0.0 7.7089 42.54786 151.28627 % Row C
surf 44 cuboid -24.31415 24.31415 -7.7089 0.0 42.54786 151.28627 % Row D
surf 45 cuboid -24.31415 24.31415 -15.4178 -7.7089 42.54786 151.28627 % Row E
surf 46 cuboid -24.31415 24.31415 -23.33625 -15.4178 42.54786 151.28627 % Row F
% ----- Radii -----
surf 71 cyl 0.0 0.0 45 42.54786 151.28627 % Model Boundary

% --- Fuel Rods -----
% ----- Horizontal Planes -----
surf 102 pz 67.54876 % Bottom of Clad Tube
surf 103 pz 68.81876 % Bottom End Fitting/Bottom Graphite Reflector Interface
surf 104 pz 77.50556 % Bottom Graphite Reflector/Moly Disc Interface
surf 105 pz 77.584935 % Moly Disc/Fuel Rods Interface
surf 106 pz 115.604935 % Fuel Rods/Top Graphite Reflector Interface
surf 107 pz 124.291735 % Top Graphite Reflector/Void Gap Interface
surf 108 pz 125.01627 % Void Gap/Top End Fitting Interface
surf 109 pz 126.28627 % Top of Clad Tube
% ----- Vertical Planes -----
surf 131 sqc 0.0 0.0 1.9431 % Lattice Boundary
% ----- Radii -----
surf 152 cyl 0.0 0.0 1.63957 % Axial Graphite Reflectors
surf 153 cyl 0.0 0.0 1.73482 % Moly Poison Disc
surf 154 cyl 0.0 0.0 0.28575 % Zirconium Rods
surf 155 cyl 0.0 0.0 0.3175 % Fuel Rod ID
surf 156 cyl 0.0 0.0 1.74025 % Fuel Rod OD
surf 157 cyl 0.0 0.0 1.7447 % Cladding Inner Surface
surf 158 cyl 0.0 0.0 1.7955 % Cladding Outer Surface

% --- Control Rods -----
% ----- Horizontal Planes -----
surf 231 pz 76.12126 % Bottom of Control Rod Clad
surf 232 pz 77.70876 % Clad/B4C Rod Interface
surf 233 pz 115.80876 % B4C Rod/Void Interface
surf 235 pz 133.58876 % Void/Clad Interface
surf 236 pz 135.55726 % Top of Control Rod Clad
% ----- Radii -----
surf 271 cyl 0.0 0.0 1.50749 % B4C Outer Surface
surf 275 cyl 0.0 0.0 1.51638 % Cladding Inner Surface
surf 276 cyl 0.0 0.0 1.5875 % Cladding Outer Surface

% --- Graphite Reflector Assemblies -----
% ----- Horizontal Planes -----
surf 9 pz 62.46876 % Bottom Assembly Boundary
surf 10 pz 128.19127 % Top Assembly Boundary
% ----- Vertical Planes -----
surf 331 octa 0.0 0.0 3.683 4.53503 % Octagonal "Cylinder"

% --- Beam Lines -----
% ----- East Beam Assembly -----
surf 402 cuboid 17.92069 51.57597 -6.985 6.985 88.33993 104.84993
% ----- North Beam Assembly -----
surf 403 cuboid -6.985 6.985 17.33395 52.54498 88.33993 104.84993

% *** Material Cards *****
% mat <name> <dens> [moder <thname> <ZA>] [tmp <T>] [vol <V>] [rgb <R> <G> <B>]
% <iso #> <frac #>
% <name> material name
% <dens> density (-mass or +atomic)
% <moder>
% <iso #> names of the constituent nuclides
% <frac #> corresponding fractions (-mass or +atomic)

```

Fundamental - FUND

NRAD-FUND-RESR-001
CRIT-REAC-COEF

```

% <thname> name of thermal scattering data library
% <ZA> nuclide ZA of the moderator nuclide
% <T> Doppler broadening temperature (K)
% <V> total material volume (cm3)
% <R> <G> <B> coloring for geometry plotter (between 0 and 255)

% --- Water -----
mat  h2o sum moder lwtr 1001 moder hwtr 1002 rgb 122 200 255
      1001.70c 6.6611E-02
      1002.70c 7.6612E-06
      8016.70c 3.3297E-02
      8017.70c 1.2658E-05
%    Total      9.9928E-02

% --- Fuel Rods (Non-Fuel Components) -----
% ----- Axial Graphite Reflectors -----
mat  axgr sum moder grph 6000 rgb 0 102 102
      6000.70c 8.6734E-02
%    Total      8.6734E-02

% ----- Moly Poison Disc -----
mat  moly sum rgb 255 179 0
      42092.70c 9.5169E-03
      42094.70c 5.9320E-03
      42095.70c 1.0210E-02
      42096.70c 1.0697E-02
      42097.70c 6.1244E-03
      42098.70c 1.5475E-02
      42100.70c 6.1757E-03
%    Total      6.4130E-02

% ----- Zr Rod -----
mat  zirc sum rgb 87 255 171
      40090.70c 2.2070E-02
      40091.70c 4.8130E-03
      40092.70c 7.3568E-03
      40094.70c 7.4555E-03
      40096.70c 1.2011E-03
%    Total      4.2897E-02

% ----- SS 304 Cladding and End Fittings -----
mat  ss304 sum moder fe56 26056 rgb 0 102 0
      6000.70c 1.6044E-04
      14028.70c 6.3283E-04
      14029.70c 3.2134E-05
      14030.70c 2.1183E-05
      15031.70c 4.0441E-05
      16032.70c 3.1374E-06
      16033.70c 2.5117E-08
      16034.70c 1.4178E-07
      16036.70c 6.6099E-10
      24050.70c 7.6491E-04
      24052.70c 1.4751E-02
      24053.70c 1.6726E-03
      24054.70c 4.1634E-04
      25055.70c 8.7693E-04
      26054.70c 3.4644E-03
      26056.70c 5.4383E-02
      26057.70c 1.2559E-03
      26058.70c 1.6714E-04
      28058.70c 5.5882E-03
      28060.70c 2.1526E-03
      28061.70c 9.3571E-05
      28062.70c 2.9834E-04
      28064.70c 7.5980E-05
%    Total      8.6851E-02

% --- Control Rods -----
% ----- B4C Absorber -----
mat  b4c sum moder grph 6000 rgb 171 87 255
      5010.70c 2.1515E-02
      5011.70c 8.6601E-02
      6000.70c 2.7029E-02
%    Total      1.3514E-01

% ----- Al 6061 Cladding and End Fittings -----

```

Fundamental - FUND

NRAD-FUND-RESR-001
CRIT-REAC-COEF

```

mat  alum sum moder al27 13027 rgb 140 26 255
      13027.70c 5.8593E-02
%    Total      5.8593E-02

% --- Graphite Reflector Assemblies -----
% ----- Graphite Reflectors -----
mat  refl sum moder grph 6000 rgb 0 102 102
      6000.70c 7.8692E-02
%    Total      7.8692E-02

% ----- 60-Rod-Average UErZrH Fuel Rod Composition -----
mat  fuel sum moder hzr 1001 moder zrh 40090 moder zrh 40091
      moder zrh 40092 moder zrh 40094 moder zrh 40096 rgb 140 255 26
      92234.70c 9.9323E-06
      92235.70c 1.0844E-03
      92236.70c 1.2036E-05
      92238.70c 4.3326E-03
      5010.70c 7.6277E-08
      5011.70c 3.0702E-07
      1001.70c 5.0608E-02
      1002.70c 5.8206E-06
      6000.70c 1.0781E-03
      40090.70c 1.6481E-02
      40091.70c 3.5940E-03
      40092.70c 5.4936E-03
      40094.70c 5.5672E-03
      40096.70c 8.9691E-04
      68162.70c 3.2517E-07
      68164.70c 3.7395E-06
      68166.70c 7.8064E-05
      68167.70c 5.3258E-05
      68168.70c 6.2200E-05
      68170.70c 3.4677E-05
      72174.70c 1.3203E-09
      72176.70c 4.3403E-08
      72177.70c 1.5348E-07
      72178.70c 2.2510E-07
      72179.70c 1.1239E-07
      72180.70c 2.8947E-07
%    Total      8.9397E-02

% --- Thermal Scattering -----
% therm <thname> <lib>
% <thname> name of data library
% <lib> library identifier in cross section library

therm lwtr lwtr.10t
therm hwtr hwtr.10t
therm grph grph.10t
therm fe56 fe56.12t
therm al27 al27.12t
therm hzr  h_zr.10t
therm zrh  zr_h.10t

% --- Cross Section Library -----
set acelib "/home/bessjd/SERPENT/xsdata/xsdata_nf7mcpn"

% --- Unresolved Resonance Data -----
% set ures <use> [<mode>] [dilu] [<iso #>]
% <use> (1) use data (0) omit data (default 0)
% <mode> calculation mode (only use mode 1, which is default)
% <dilu> infinite dilution cut-off (default is 0)
% <iso #> nuclides for which data is used or omitted (default uses all)

set ures 1

% *** Control Cards *****
% --- Boundary Condition -----
% (1) black boundary (2) reflective boundary (3) periodic boundary (moved to other side)

set bc 1 % Vacuum

% --- Neutron Population and Criticality Cycles -----
% set pop <npop> <cycles> <skip> [<keff0> <int>]
% <npop> # source neutrons per cycle
% <cycles> # active cycles run

```

Fundamental - FUND

NRAD-FUND-RESR-001
 CRIT-REAC-COEF

```

% <skip> # inactive cycles run
% <keff0> initial guess for keff
% <int> collection interval (default=1)

set pop 100000 2500 50 1.0
% set power 30 % Watts

% --- Geometry and Mesh Plots -----
% plot <or> <nx> <ny> [<p> <min1> <max1> <min2> <max2>]
% <or> plot plane orientation (1) yz-plot (2) xz-plot (3) xy-plot
% <nx> width of plot in pixels
% <ny> height of plot in pixels
% <p> position on axis perpendicular to plot plane
% <min#/max#> minimum/maximum value of # coordinate

% * Figures are inverted Top/Bottom from actual geometry *
plot 1 3000 3000 5.99313 -45.0 45.0 42.54786 151.28627
plot 2 3000 3000 5.79605 -45.0 45.0 42.54786 151.28627
plot 3 3000 3000 96.594935 -45.0 45.0 -45.0 45.0

% mesh <or> <nx> <ny> [<sym> <x0> <x1> <y0> <y1> <z0> <z1>]
% <or> plot plane orientation (1) yz-plot (2) xz-plot (3) xy-plot
% <nx> width of plot in pixels
% <ny> height of plot in pixels
% <sym> symmetry option (0) none (2) half (4) quarter (8) eighth
% <x/y/z-0/1> min/max value on x/y/z-coordinate

% * Figures are inverted Top/Bottom from actual geometry *
mesh 1 5000 5000 0 4.25288 7.73338 -45.0 45.0 42.54786 151.28627
mesh 2 5000 5000 0 -45.0 45.0 4.0558 7.5363 42.54786 151.28627
mesh 3 5000 5000 0 -45.0 45.0 -45.0 45.0 77.584935 115.604935

```

SERPENT Input Deck for the 60-fuel-element operational core configuration (Case 2):

```

% !!! NRAD Reactor 60-Fuel-Element Core !!!!!!!!!!!!!!!!!!!!!!!!!!!!!!!!!!!!!!!!!!!!!!!
% John Darrell Bess - Idaho National Laboratory
% Last Updated: March 1, 2012
% !!!!!!!!!!!!!!!!!!!!!!!!!!!!!!!!!!!!!!!!!!!!!!!!!!!!!!!!!!!!!!!!!!!!!!!!!!!!!!!!!!!!!

set title "NRAD 60"

% *** Cell Cards ****
% cell <name> <u0> <mat> <surf #>
% <name> cell name
% <u0> universe number of cell
% <mat> cell material (if cell is empty, material name is set to "void")
%                               (if cell is geometry boundary, it is set to "outside")
%                               (if cell is filled, it is set to "fill" followed by universe #)
% <surf #> boundary surfaces

% universe transformation (not needed in lattices)
% trans <u> <x> <y> <z>
% <u> universe number
% <x,y,z> x,y,z-coordinate of new origin

% lattice descriptions
% lat <u0> <type> <x0> <y0> <nx> <ny> <p>
% <u0> universe number of lattice
% <type> lattice type (1) square (2) x-type hexagonal (2) y-type hexagonal
%                               (4) circular (6,7,8) infinite of types 1,2,3 (9) vertical stack
% <x0/y0> x-/y-coordinate of the lattice origin
% <nx/ny> number of lattice elements in the x-/y-direction
% <p> lattice pitch

% --- Assemblies -----
% ----- Graphite Reflector -----
cell block 200 refl 9 -10 -331 % Graphite Block
cell h2ob1 200 h2o 9 -10 331 % Water Around Assembly
cell h2ob2 200 h2o -9 % Water Below Assembly
cell h2ob3 200 h2o 10 % Water Above Assembly

% ----- Fuel Rod -----
cell bfcap 301 ss304 102 -103 -157 % Bottom End Cap
cell baxgr 301 axgr 103 -104 -152 % Bottom Graphite Reflector
cell fgap1 301 void 103 -104 152 -157 % Gap Around Bottom Graphite Reflector
cell pdisc 301 moly 104 -105 -153 % Moly Poison Disc
cell fgap2 301 void 104 -105 153 -157 % Gap Around Moly Poison Disc
cell zrrrod 301 zirc 105 -106 -154 % Zirconium Rod
cell fgap3 301 void 105 -106 154 -155 % Zr/Fuel Gap
cell fuel 301 fuel 105 -106 155 -156 % Fuel Rod
cell fgap4 301 void 105 -106 156 -157 % Gap Around Fuel Rod
cell taxgr 301 axgr 106 -107 -152 % Top Graphite Reflector
cell fgap5 301 void 106 -107 152 -157 % Gap Around Top Graphite Reflector
cell fgap6 301 void 107 -108 -157 % Gap Above Top Graphite Reflector
cell tfcap 301 ss304 108 -109 -157 % Top End Cap
cell fclad 301 ss304 102 -109 157 -158 % Cladding
cell h2of1 301 h2o 102 -109 158 % Water Around Fuel
cell h2of2 301 h2o -102 % Water Below Fuel
cell h2of3 301 h2o 109 % Water Above Fuel

% ----- Control Rods -----
cell bacap 401 alum 231 -232 -275 % Bottom End Fitting
cell cr 401 b4c 232 -233 -271 % Absorber Rod
cell agap1 401 void 232 -233 271 -275 % Gap Around Absorber Rod
cell agap2 401 void 233 -235 -275 % Gap Above Absorber Rod
cell tacap 401 alum 235 -236 -275 % Top End Fitting
cell aclad 401 alum 231 -236 275 -276 % Cladding
cell h2oa1 401 h2o 231 -236 276 % Water Around Control Rod
cell h2oa2 401 h2o -231 % Water Below Control Rod
cell h2oa3 401 h2o 236 % Water Above Control Rod

cell shim1 402 fill 401 -1 % Shim 1 Control Rod
trans 402 0.0 0.0 38.1
cell shim2 403 fill 401 -1 % Shim 2 Control Rod
trans 403 0.0 0.0 38.1
cell reg 404 fill 401 -1 % Reg Control Rod
trans 404 0.0 0.0 20.4216

```

Fundamental - FUND

NRAD-FUND-RESR-001
CRIT-REAC-COEF

```

% * Control Rods are fully inserted when the translated values 0 0 0 *
% * Control Rods are fully withdrawn when the translated values are 0 0 38.1), *
% * which corresponds to 1000 units withdrawn *

% ----- 4-Rod Fuel Cluster -----
cell wat1 999 h2o -1 % water
lat 101 1 0.0 0.0 4 4 3.8862
999 999 999 999
999 301 301 999
999 301 301 999
999 999 999 999
cell 4rods 300 fill 101 -31 % Fuel Bundle
cell h2on1 300 h2o 31 % Water Around Bundle

% ----- Position D-2 : Shim Rod 1 Control Cluster -----
lat 102 1 0.0 0.0 4 4 3.8862
999 999 999 999
999 301 402 999
999 301 301 999
999 999 999 999
cell 3shml 400 fill 102 -31 % Fuel Bundle
cell h2on2 400 h2o 31 % Water Around Bundle

% ----- Position C-2 : Shim Rod 2 Control Cluster -----
lat 103 1 0.0 0.0 4 4 3.8862
999 999 999 999
999 301 301 999
999 301 403 999
999 999 999 999
cell 3shml 500 fill 103 -31 % Fuel Bundle
cell h2on3 500 h2o 31 % Water Around Bundle

% ----- Position E-4 : Regulating Rod Control Cluster -----
lat 104 1 0.0 0.0 4 4 3.8862
999 999 999 999
999 301 301 999
999 301 404 999
999 999 999 999
cell 3reg 600 fill 104 -31 % Fuel Bundle
cell h2on4 600 h2o 31 % Water Around Bundle

% ----- Position C-4 : Sample Irradiation Cluster -----
lat 105 1 0.0 0.0 4 4 3.8862
999 999 999 999
999 999 301 999
999 301 301 999
999 999 999 999
cell 3irr 700 fill 105 -31 % Fuel Bundle
cell h2on5 700 h2o 31 % Water Around Bundle

% --- Beam Lines -----
cell ebeam 0 void -402 -71 % East Beam Filter Tube
cell nbeam 0 void -403 -71 % North Beam Filter Tube

% --- NRAD Reactor -----
% ----- Assembly Rows -----
cell wat2 998 h2o -1 % water
lat 901 1 0.0 0.0 8 9 8.10006
998 998 998 998 998 998 998 998
998 998 998 998 998 998 998 998
998 998 998 998 998 998 998 998
998 998 998 998 998 998 998 998
998 998 200 998 998 200 998 998
998 998 998 998 998 998 998 998
998 998 998 998 998 998 998 998
998 998 998 998 998 998 998 998
998 998 998 998 998 998 998 998
cell rowA 911 fill 901 -35 % Row A
cell h2oA 911 h2o 35
trans 911 0.0 19.27225 0.0
cell rowA2 0 fill 911 -41 403 % Row A

lat 902 1 0.0 0.0 8 9 8.10006
998 998 998 998 998 998 998 998
998 998 998 998 998 998 998 998
998 998 998 998 998 998 998 998

```

Fundamental - FUND

NRAD-FUND-RESR-001
CRIT-REAC-COEF

```

998 998 998 998 998 998 998 998
998 200 300 300 300 300 200 998
998 998 998 998 998 998 998 998
998 998 998 998 998 998 998 998
998 998 998 998 998 998 998 998
998 998 998 998 998 998 998 998
cell rowB 912 fill 902 -35 % Row B
cell h2oB 912 h2o 35
trans 912 0.0 11.56335 0.0
cell rowB2 0 fill 912 -42 % Row B

lat 903 1 0.0 0.0 8 9 8.10006
998 998 998 998 998 998 998 998
998 998 998 998 998 998 998 998
998 998 998 998 998 998 998 998
998 998 998 998 998 998 998 998
998 200 500 300 700 300 998 998
998 998 998 998 998 998 998 998
998 998 998 998 998 998 998 998
998 998 998 998 998 998 998 998
998 998 998 998 998 998 998 998
cell rowC 913 fill 903 -35 % Row C
cell h2oC 913 h2o 35
trans 913 0.0 3.85445 0.0
cell rowC2 0 fill 913 -43 402 % Row C

lat 904 1 0.0 0.0 8 9 8.10006
998 998 998 998 998 998 998 998
998 998 998 998 998 998 998 998
998 998 998 998 998 998 998 998
998 998 998 998 998 998 998 998
998 200 400 300 300 300 998 998
998 998 998 998 998 998 998 998
998 998 998 998 998 998 998 998
998 998 998 998 998 998 998 998
998 998 998 998 998 998 998 998
cell rowD 914 fill 904 -35 % Row D
cell h2oD 914 h2o 35
trans 914 0.0 -3.85445 0.0
cell rowD2 0 fill 914 -44 402 % Row D

lat 905 1 0.0 0.0 8 9 8.10006
998 998 998 998 998 998 998 998
998 998 998 998 998 998 998 998
998 998 998 998 998 998 998 998
998 998 998 998 998 998 998 998
998 200 300 300 600 300 200 998
998 998 998 998 998 998 998 998
998 998 998 998 998 998 998 998
998 998 998 998 998 998 998 998
998 998 998 998 998 998 998 998
cell rowE 915 fill 905 -35 % Row E
cell h2oE 915 h2o 35
trans 915 0.0 -11.56335 0.0
cell rowE2 0 fill 915 -45 % Row E

lat 906 1 0.0 0.0 8 9 8.10006
998 998 998 998 998 998 998 998
998 998 998 998 998 998 998 998
998 998 998 998 998 998 998 998
998 998 998 998 998 998 998 998
998 998 200 200 200 200 998 998
998 998 998 998 998 998 998 998
998 998 998 998 998 998 998 998
998 998 998 998 998 998 998 998
998 998 998 998 998 998 998 998
cell rowF 916 fill 906 -35 % Row F
cell h2oF 916 h2o 35
trans 916 0.0 -19.27225 0.0
cell rowF2 0 fill 916 -46 % Row F

cell wat3 0 h2o 41 42 43 44 45 46 -35 % Water
cell core 0 h2o 402 403 35 -71 % Benchmark Model

cell void 0 outside 71

```

Fundamental - FUND

NRAD-FUND-RESR-001
CRIT-REAC-COEF

```

% *** Surface Cards *****
% surf <id> <type> <param #>
% <id> surface identifier
% <type> surface type
% <param #> surface parameters

% --- Primary Model Dimensions -----
surf 1 inf
% ----- Vertical Planes -----
surf 31 cuboid -4.05003 4.05003 -3.85445 3.85445 42.54786 151.28627 % Assembly Positions
surf 35 cuboid -24.31415 24.31415 -23.33625 23.33625 42.54786 151.28627 % Core Boundary
surf 41 cuboid -24.31415 24.31415 15.4178 23.33625 42.54786 151.28627 % Row A
surf 42 cuboid -24.31415 24.31415 7.7089 15.4178 42.54786 151.28627 % Row B
surf 43 cuboid -24.31415 24.31415 0.0 7.7089 42.54786 151.28627 % Row C
surf 44 cuboid -24.31415 24.31415 -7.7089 0.0 42.54786 151.28627 % Row D
surf 45 cuboid -24.31415 24.31415 -15.4178 -7.7089 42.54786 151.28627 % Row E
surf 46 cuboid -24.31415 24.31415 -23.33625 -15.4178 42.54786 151.28627 % Row F
% ----- Radii -----
surf 71 cyl 0.0 0.0 45 42.54786 151.28627 % Model Boundary

% --- Fuel Rods -----
% ----- Horizontal Planes -----
surf 102 pz 67.54876 % Bottom of Clad Tube
surf 103 pz 68.81876 % Bottom End Fitting/Bottom Graphite Reflector Interface
surf 104 pz 77.50556 % Bottom Graphite Reflector/Moly Disc Interface
surf 105 pz 77.584935 % Moly Disc/Fuel Rods Interface
surf 106 pz 115.604935 % Fuel Rods/Top Graphite Reflector Interface
surf 107 pz 124.291735 % Top Graphite Reflector/Void Gap Interface
surf 108 pz 125.01627 % Void Gap/Top End Fitting Interface
surf 109 pz 126.28627 % Top of Clad Tube
% ----- Vertical Planes -----
surf 131 sqc 0.0 0.0 1.9431 % Lattice Boundary
% ----- Radii -----
surf 152 cyl 0.0 0.0 1.63957 % Axial Graphite Reflectors
surf 153 cyl 0.0 0.0 1.73482 % Moly Poison Disc
surf 154 cyl 0.0 0.0 0.28575 % Zirconium Rods
surf 155 cyl 0.0 0.0 0.3175 % Fuel Rod ID
surf 156 cyl 0.0 0.0 1.74025 % Fuel Rod OD
surf 157 cyl 0.0 0.0 1.7447 % Cladding Inner Surface
surf 158 cyl 0.0 0.0 1.7955 % Cladding Outer Surface

% --- Control Rods -----
% ----- Horizontal Planes -----
surf 231 pz 76.12126 % Bottom of Control Rod Clad
surf 232 pz 77.70876 % Clad/B4C Rod Interface
surf 233 pz 115.80876 % B4C Rod/Void Interface
surf 235 pz 133.58876 % Void/Clad Interface
surf 236 pz 135.55726 % Top of Control Rod Clad
% ----- Radii -----
surf 271 cyl 0.0 0.0 1.50749 % B4C Outer Surface
surf 275 cyl 0.0 0.0 1.51638 % Cladding Inner Surface
surf 276 cyl 0.0 0.0 1.5875 % Cladding Outer Surface

% --- Graphite Reflector Assemblies -----
% ----- Horizontal Planes -----
surf 9 pz 62.46876 % Bottom Assembly Boundary
surf 10 pz 128.19127 % Top Assembly Boundary
% ----- Vertical Planes -----
surf 331 octa 0.0 0.0 3.683 4.53503 % Octagonal "Cylinder"

% --- Beam Lines -----
% ----- East Beam Assembly -----
surf 402 cuboid 17.92069 51.57597 -6.985 6.985 88.33993 104.84993
% ----- North Beam Assembly -----
surf 403 cuboid -6.985 6.985 17.33395 52.54498 88.33993 104.84993

% *** Material Cards *****
% mat <name> <dens> [moder <thname> <ZA>] [tmp <T>] [vol <V>] [rgb <R> <G> <B>]
% <iso #> <frac #>
% <name> material name
% <dens> density (-mass or +atomic)
% <moder
% <iso #> names of the constituent nuclides
% <frac #> corresponding fractions (-mass or +atomic)

```

Fundamental - FUND

NRAD-FUND-RESR-001
CRIT-REAC-COEF

```

% <thname> name of thermal scattering data library
% <ZA> nuclide ZA of the moderator nuclide
% <T> Doppler broadening temperature (K)
% <V> total material volume (cm3)
% <R> <G> <B> coloring for geometry plotter (between 0 and 255)

% --- Water -----
mat h2o sum moder lwtr 1001 moder hwtr 1002 rgb 122 200 255
    1001.70c 6.6611E-02
    1002.70c 7.6612E-06
    8016.70c 3.3297E-02
    8017.70c 1.2658E-05
% Total 9.9928E-02

% --- Fuel Rods (Non-Fuel Components) -----
% ----- Axial Graphite Reflectors -----
mat axgr sum moder grph 6000 rgb 0 102 102
    6000.70c 8.6734E-02
% Total 8.6734E-02

% ----- Moly Poison Disc -----
mat moly sum rgb 255 179 0
    42092.70c 9.5169E-03
    42094.70c 5.9320E-03
    42095.70c 1.0210E-02
    42096.70c 1.0697E-02
    42097.70c 6.1244E-03
    42098.70c 1.5475E-02
    42100.70c 6.1757E-03
% Total 6.4130E-02

% ----- Zr Rod -----
mat zirc sum rgb 87 255 171
    40090.70c 2.2070E-02
    40091.70c 4.8130E-03
    40092.70c 7.3568E-03
    40094.70c 7.4555E-03
    40096.70c 1.2011E-03
% Total 4.2897E-02

% ----- SS 304 Cladding and End Fittings -----
mat ss304 sum moder fe56 26056 rgb 0 102 0
    6000.70c 1.6044E-04
    14028.70c 6.3283E-04
    14029.70c 3.2134E-05
    14030.70c 2.1183E-05
    15031.70c 4.0441E-05
    16032.70c 3.1374E-06
    16033.70c 2.5117E-08
    16034.70c 1.4178E-07
    16036.70c 6.6099E-10
    24050.70c 7.6491E-04
    24052.70c 1.4751E-02
    24053.70c 1.6726E-03
    24054.70c 4.1634E-04
    25055.70c 8.7693E-04
    26054.70c 3.4644E-03
    26056.70c 5.4383E-02
    26057.70c 1.2559E-03
    26058.70c 1.6714E-04
    28058.70c 5.5882E-03
    28060.70c 2.1526E-03
    28061.70c 9.3571E-05
    28062.70c 2.9834E-04
    28064.70c 7.5980E-05
% Total 8.6851E-02

% --- Control Rods -----
% ----- B4C Absorber -----
mat b4c sum moder grph 6000 rgb 171 87 255
    5010.70c 2.1515E-02
    5011.70c 8.6601E-02
    6000.70c 2.7029E-02
% Total 1.3514E-01

% ----- Al 6061 Cladding and End Fittings -----

```

Fundamental - FUND

NRAD-FUND-RESR-001
CRIT-REAC-COEF

```

mat  alum sum moder al27 13027 rgb 140 26 255
      13027.70c 5.8593E-02
%    Total      5.8593E-02

% --- Graphite Reflector Assemblies -----
% ----- Graphite Reflectors -----
mat  refl sum moder grph 6000 rgb 0 102 102
      6000.70c 7.8692E-02
%    Total      7.8692E-02

% ----- 60-Rod-Average UErZrH Fuel Rod Composition -----
mat  fuel sum moder hzr 1001 moder zrh 40090 moder zrh 40091
      moder zrh 40092 moder zrh 40094 moder zrh 40096 rgb 140 255 26
      92234.70c 9.9323E-06
      92235.70c 1.0844E-03
      92236.70c 1.2036E-05
      92238.70c 4.3326E-03
      5010.70c 7.6277E-08
      5011.70c 3.0702E-07
      1001.70c 5.0608E-02
      1002.70c 5.8206E-06
      6000.70c 1.0781E-03
      40090.70c 1.6481E-02
      40091.70c 3.5940E-03
      40092.70c 5.4936E-03
      40094.70c 5.5672E-03
      40096.70c 8.9691E-04
      68162.70c 3.2517E-07
      68164.70c 3.7395E-06
      68166.70c 7.8064E-05
      68167.70c 5.3258E-05
      68168.70c 6.2200E-05
      68170.70c 3.4677E-05
      72174.70c 1.3203E-09
      72176.70c 4.3403E-08
      72177.70c 1.5348E-07
      72178.70c 2.2510E-07
      72179.70c 1.1239E-07
      72180.70c 2.8947E-07
%    Total      8.9397E-02

% --- Thermal Scattering -----
% therm <thname> <lib>
% <thname> name of data library
% <lib> library identifier in cross section library

therm lwtr lwtr.10t
therm hwtr hwtr.10t
therm grph grph.10t
therm fe56 fe56.12t
therm al27 al27.12t
therm hzr  h_zr.10t
therm zrh  zr_h.10t

% --- Cross Section Library -----
set acelib "/home/bessjd/SERPENT/xsdata/xsdata_nf7mcpn"

% --- Unresolved Resonance Data -----
% set ures <use> [<mode>] [dilu] [<iso #>]
% <use> (1) use data (0) omit data (default 0)
% <mode> calculation mode (only use mode 1, which is default)
% <dilu> infinite dilution cut-off (default is 0)
% <iso #> nuclides for which data is used or omitted (default uses all)

set ures 1

% *** Control Cards *****
% --- Boundary Condition -----
% (1) black boundary (2) reflective boundary (3) periodic boundary (moved to other side)

set bc 1 % Vacuum

% --- Neutron Population and Criticality Cycles -----
% set pop <npop> <cycles> <skip> [<keff0> <int>]
% <npop> # source neutrons per cycle
% <cycles> # active cycles run

```

Fundamental - FUND

NRAD-FUND-RESR-001
CRIT-REAC-COEF

```

% <skip> # inactive cycles run
% <keff0> initial guess for keff
% <int> collection interval (default=1)

set pop 100000 2500 50 1.0
% set power 30 % Watts

% --- Geometry and Mesh Plots -----
% plot <or> <nx> <ny> [<p> <min1> <max1> <min2> <max2>]
% <or> plot plane orientation (1) yz-plot (2) xz-plot (3) xy-plot
% <nx> width of plot in pixels
% <ny> height of plot in pixels
% <p> position on axis perpendicular to plot plane
% <min#/max#> minimum/maximum value of # coordinate

% * Figures are inverted Top/Bottom from actual geometry *
plot 1 3000 3000 5.99313 -45.0 45.0 42.54786 151.28627
plot 2 3000 3000 5.79605 -45.0 45.0 42.54786 151.28627
plot 3 3000 3000 96.594935 -45.0 45.0 -45.0 45.0

% mesh <or> <nx> <ny> [<sym> <x0> <x1> <y0> <y1> <z0> <z1>]
% <or> plot plane orientation (1) yz-plot (2) xz-plot (3) xy-plot
% <nx> width of plot in pixels
% <ny> height of plot in pixels
% <sym> symmetry option (0) none (2) half (4) quarter (8) eighth
% <x/y/z-0/1> min/max value on x/y/z-coordinate

% * Figures are inverted Top/Bottom from actual geometry *
mesh 1 5000 5000 0 4.25288 7.73338 -45.0 45.0 42.54786 151.28627
mesh 2 5000 5000 0 -45.0 45.0 4.0558 7.5363 42.54786 151.28627
mesh 3 5000 5000 0 -45.0 45.0 -45.0 45.0 77.584935 115.604935

```

A.2 Buckling and Extrapolation Length Configurations

Buckling and extrapolation length measurements were not made.

A.3 Spectral-Characteristics Configurations

Spectral characteristics measurements were not made.

A.4 Reactivity-Effects Configurations

The input decks for analysis of most reactivity effects measurements are those of the critical configurations (Appendix A.1 described in Section 3.1) with adjustments discussed in Section 3.4.2.

A separate model was developed to include the experiment dry tube (Section 3.4.2.5).

MCNP5 Input Deck for the 60-fuel-element operational core configuration with experiment dry tube (Case 15):

```
FRESH-CORE RELOAD OF THE NRAD REACTOR WITH U(20)-ER-ZR-H FUEL (SIMPLE)
c
c John Darrell Bess - Idaho National Laboratory
c Last Updated: January 3, 2012
c
c Cell Cards *****
c --- Assemblies -----
c ----- Graphite Reflector -----
201  8 7.8692E-02 (9 -10) (331 -332 333 -334) (-335 -336 -337 -338)
      imp:n=1 u=200 $ Graphite Block
202  1 9.9928E-02 -9:10:-331:332:-333:334:335:336:337:338 imp:n=1 u=200 $ Water Around Assembly
c
c ----- Fuel Rod -----
301  5 8.6851E-02 102 -103 -157 imp:n=1 u=301 $ Bottom End Cap
302  2 8.6734E-02 103 -104 -152 imp:n=1 u=301 $ Bottom Graphite Reflector
303  3 6.4130E-02 104 -105 -153 imp:n=1 u=301 $ Moly Poison Disc
304  4 4.2897E-02 105 -106 -154 imp:n=1 u=301 $ Zirconium Rod
305  0      105 -106 154 -155 imp:n=1 u=301 $ Zr/Fuel Gap
306  9 8.9397E-02 105 -106 155 -156 imp:n=1 u=301 $ Fuel Rod
307  2 8.6734E-02 106 -107 -152 imp:n=1 u=301 $ Top Graphite Reflector
308  0 (-103:104:152) (-104:105:153) (-105:106:156) (-106:107:152)
      (103 -108 -157) imp:n=1 u=301 $ Void Gap
309  5 8.6851E-02 102 -109 157 -158 imp:n=1 u=301 $ Cladding
310  5 8.6851E-02 108 -109 -157 imp:n=1 u=301 $ Top End Cap
311  1 9.9928E-02 158:-102:109 imp:n=1 u=301 $ Water
c
c ----- Control Rods -----
401  7 5.8593E-02 231 -232 -275 imp:n=1 u=401 $ Bottom End Fitting
402  6 1.3514E-01 232 -233 -271 imp:n=1 u=401 $ Absorber
403  0 (232 -233 271 -275):(233 -235 -275) imp:n=1 u=401 $ Void Space
404  7 5.8593E-02 235 -236 -275 imp:n=1 u=401 $ Top End Fitting
405  7 5.8593E-02 231 -236 275 -276 imp:n=1 u=401 $ Cladding
406  1 9.9928E-02 -231:236:276 imp:n=1 u=401 $ Water around Control Rod
c
407  0 3 -13 imp:n=1 u=402 fill=401 (0 0 38.1) $ Shim 1 Control Rod
408  0 3 -13 imp:n=1 u=403 fill=401 (0 0 38.1) $ Shim 2 Control Rod
409  0 3 -13 imp:n=1 u=404 fill=401 (0 0 20.4216) $ Reg Control Rod
c
c * Control Rods are fully inserted when the values in parenthesis are (0 0 0) *
c * Control Rods are fully withdrawn when the values are (0 0 38.1), which *
c * corresponds to 1000 units withdrawn *
c
c ----- 4-Rod Fuel Cluster -----
501  1 9.9928E-02 -132 131 -134 133 imp:n=1 u=101 lat=1 fill=-1:2 -1:2 0:0 $ Fuel Assemblies
      101 101 101 101
      101 301 301 101
      101 301 301 101
      101 101 101 101
```

Fundamental - FUND

NRAD-FUND-RESR-001
CRIT-REAC-COEF

```

502 0 3 -13 imp:n=1 u=300 fill=101 (-1.9431 -1.9431 0) $ Fuel Bundle
c
c ----- Position D-2 : Shim Rod 1 Control Cluster -----
511 1 9.9928E-02 -132 131 -134 133 imp:n=1 u=102 lat=1 fill=-1:2 -1:2 0:0 $ Fuel Assemblies
    102 102 102 102
    102 301 402 102
    102 301 301 102
    102 102 102 102
512 0 3 -13 imp:n=1 u=400 fill=102 (-1.9431 -1.9431 0) $ Fuel Bundle
c
c ----- Position C-2 : Shim Rod 2 Control Cluster -----
521 1 9.9928E-02 -132 131 -134 133 imp:n=1 u=103 lat=1 fill=-1:2 -1:2 0:0 $ Fuel Assemblies
    103 103 103 103
    103 301 301 103
    103 301 403 103
    103 103 103 103
522 0 3 -13 imp:n=1 u=500 fill=103 (-1.9431 -1.9431 0) $ Fuel Bundle
c
c ----- Position E-4 : Regulating Rod Control Cluster -----
531 1 9.9928E-02 -132 131 -134 133 imp:n=1 u=104 lat=1 fill=-1:2 -1:2 0:0 $ Fuel Assemblies
    104 104 104 104
    104 301 301 104
    104 301 404 104
    104 104 104 104
532 0 3 -13 imp:n=1 u=600 fill=104 (-1.9431 -1.9431 0) $ Fuel Bundle
c
c ----- Position C-4 : Sample Irradiation Cluster -----
541 1 9.9928E-02 -132 131 -134 133 imp:n=1 u=105 lat=1 fill=-1:2 -1:2 0:0 $ Fuel Assemblies
    105 105 105 105
    105 105 301 105
    105 301 301 105
    105 105 105 105
542 0 3 -13 imp:n=1 u=700 fill=105 (-1.9431 -1.9431 0) $ Fuel Bundle
c
c ----- Position F-1 : Dry Tube -----
551 7 5.8593E-02 102 -600 -652 imp:n=1 $ Bottom of Dry Tube
552 7 5.8593E-02 102 -13 652 -651 imp:n=1 $ Dry Tube
553 0 600 -13 -652 imp:n=1 $ Void Space
c
c --- Beam Lines -----
601 0 402 -403 432 -433 431 -434 -71 imp:n=1 $ East Beam Filter Tube
602 0 402 -403 532 -533 531 -534 -71 imp:n=1 $ North Beam Filter Tube
c
c --- NRAD Reactor -----
c ----- Core Map -----
701 1 9.9928E-02 -32 31 -34 33 imp:n=1 u=100 lat=1 fill=-4:5 -4:5 0:0
    100 100 100 100 100 100 100 100 100 100
    100 100 100 100 100 100 100 100 100 100
    100 100 100 200 200 200 200 100 100 100
    100 100 200 300 300 600 300 200 100 100
    100 100 200 400 300 300 300 100 100 100
    100 100 200 500 300 700 300 100 100 100
    100 100 200 300 300 300 300 200 100 100
    100 100 100 200 100 100 200 100 100 100
    100 100 100 100 100 100 100 100 100 100
    100 100 100 100 100 100 100 100 100 100
c
c ----- Core Map Legend -----
c H2O H2O H2O H2O H2O H2O H2O H2O H2O H2O
c H2O Grid Grid Grid Grid Grid Grid Grid Grid Grid H2O
c H2O Grid Grid Grph Srce Grph Grph Grid Grid H2O
c H2O Grid Grph Fuel Fuel Reg Fuel Grph Grid H2O
c H2O Grid Grph Shm1 Fuel Fuel Fuel EaBm Grid H2O
c H2O Grid Grph Shm2 Fuel Hole Fuel EaBm Grid H2O
c H2O Grid Grph Fuel Fuel Fuel Fuel Grph Grid H2O
c H2O Grid Grid Grph NoBm NoBm Grph Grid Grid H2O
c H2O Grid Grid Grid Grid Grid Grid Grid Grid H2O
c H2O H2O H2O H2O H2O H2O H2O H2O H2O H2O
c
c EaBm = East Beam Support (Modeled as H2O)
c Fuel = Four Fuel Cluster
c Grid = Empty Grid Position (or Grid Edge) (Modeled as H2O)
c Grph = Graphite Block Reflector
c H2O = Water
c Hole = Water Hole (Irradiation Position)
c NoBm = North Beam Support (Modeled as H2O)

```

Fundamental - FUND

NRAD-FUND-RESR-001
CRIT-REAC-COEF

```

c   Reg = Regulating Rod Cluster
c   Shm1 = Shim Rod 1 Cluster
c   Shm2 = Shim Rod 2 Cluster
c   Srce = Graphite Block Reflector (AmBe Source) (Modeled as Graphite Block)
c
c ----- Core Map Positions -----
c   H2O  H2O  H2O  H2O  H2O  H2O  H2O  H2O  H2O  H2O
c   H2O Grid Grid Grid Grid Grid Grid Grid Grid Grid H2O
c   H2O Grid F-1 F-2 F-3 F-4 F-5 F-6 Grid H2O
c   H2O Grid E-1 E-2 E-3 E-4 E-5 E-6 Grid H2O
c   H2O Grid D-1 D-2 D-3 D-4 D-5 D-6 Grid H2O
c   H2O Grid C-1 C-2 C-3 C-4 C-5 C-6 Grid H2O
c   H2O Grid B-1 B-2 B-3 B-4 B-5 B-6 Grid H2O
c   H2O Grid A-1 A-2 A-3 A-4 A-5 A-6 Grid H2O
c   H2O Grid Grid Grid Grid Grid Grid Grid Grid H2O
c   H2O  H2O  H2O  H2O  H2O  H2O  H2O  H2O  H2O  H2O
c
c   Note: Visual Core Map is Mirrored Vertically Compared to Actual Positions
c
702  0 (-36 35 -38 37 -13 3) (-402:403:-532:533:-531) (-402:403:-432:433:-431)
      (-102:651) imp:n=1 fill=100 (-4.05003 -3.85445 0) $ Core
703  1 9.9928E-02 (36:-35:38:-37) (-402:403:-532:533:-531)
      (-402:403:-432:433:-431) 3 -13 -71 imp:n=1 $ Tank Water
c
c --- Model Boundary -----
901  0 -3:13:71 imp:n=0
c
c Surface Cards *****
c --- Primary Model Dimensions -----
c ----- Horizontal Planes -----
3   pz  42.54876 $ Bottom Model Boundary
9   pz  62.46876 $ Bottom Assembly Boundary
10  pz  128.19127 $ Top Assembly Boundary
13  pz  151.28627 $ Top Model Boundary
c
c ----- Vertical Planes -----
31  px  -4.05003 $ West Assembly Boundary
32  px   4.05003 $ East Assembly Boundary
33  py  -3.85445 $ South Assembly Boundary
34  py   3.85445 $ North Assembly Boundary
35  px  -24.31415 $ West Edge of Grid Plate
36  px   24.31415 $ East Edge of Grid Plate
37  py  -23.33625 $ South Edge of Grid Plate
38  py   23.33625 $ North Edge of Grid Plate
c
c ----- Radii -----
71  cz  45      $ Radial Model Boundary
c
c --- Fuel Rods -----
c ----- Horizontal Planes -----
102 pz  67.54876 $ Bottom of Clad Tube
103 pz  68.81876 $ Bottom End Fitting/Bottom Graphite Reflector Interface
104 pz  77.50556 $ Bottom Graphite Reflector/Moly Disc Interface
105 pz  77.584935 $ Moly Disc/Fuel Rods Interface
106 pz  115.604935 $ Fuel Rods/Top Graphite Reflector Interface
107 pz  124.291735 $ Top Graphite Reflector/Void Gap Interface
108 pz  125.01627 $ Void Gap/Top End Fitting Interface
109 pz  126.28627 $ Top of Clad Tube
c
c ----- Vertical Planes -----
131 px  -1.9431  $ West Fuel Boundary
132 px   1.9431  $ East Fuel Boundary
133 py  -1.9431  $ South Fuel Boundary
134 py   1.9431  $ North Fuel Boundary
c
c ----- Radii -----
152 cz  1.63957  $ Axial Graphite Reflectors
153 cz  1.73482  $ Moly Poison Disc
154 cz  0.28575  $ Zirconium Rods
155 cz  0.3175   $ Fuel Rod ID
156 cz  1.74025  $ Fuel Rod OD
157 cz  1.7447   $ Cladding Inner Surface
158 cz  1.7955   $ Cladding Outer Surface
c
c --- Control Rods -----

```

Fundamental - FUND

NRAD-FUND-RESR-001
CRIT-REAC-COEF

```

c ----- Horizontal Planes -----
231 pz 76.12126 $ Bottom of Control Rod Clad
232 pz 77.70876 $ Clad/B4C Rod Interface
233 pz 115.80876 $ B4C Rod/Void Interface
235 pz 133.58876 $ Void/Clad Interface
236 pz 135.55726 $ Top of Control Rod Clad
c
c ----- Radii -----
271 cz 1.50749 $ B4C Outer Surface
275 cz 1.51638 $ Cladding Inner Surface
276 cz 1.5875 $ Cladding Outer Surface
c
c --- Graphite Reflector Assemblies -----
c ----- Vertical Planes -----
331 px -3.683 $ West Graphite Surface
332 px 3.683 $ East Graphite Surface
333 py -3.683 $ South Graphite Surface
334 py 3.683 $ North Graphite Surface
335 p -3.683 2.7305 1 -3.683 2.7305 -1 -2.7305 3.683 1 $ NW Chamfer
336 p 3.683 2.7305 1 3.683 2.7305 -1 2.7305 3.683 1 $ NE Chamfer
337 p -3.683 -2.7305 1 -3.683 -2.7305 -1 -2.7305 -3.683 1 $ SW Chamfer
338 p 3.683 -2.7305 1 3.683 -2.7305 -1 2.7305 -3.683 1 $ SE Chamfer
c
c --- Beam Lines -----
c ----- Horizontal Planes -----
402 pz 88.33993 $ Bottom Surface of Beam Filter Tubes
403 pz 104.84993 $ Top Surface of Beam Filter Tubes
c
c ----- Vertical Planes -----
c ----- East Beam Assembly -----
431 px 17.92069 $ Core Face of Beam Filter Tube
432 py -6.985 $ South Surface of Beam Filter Tube
433 py 6.985 $ North Surface of Beam Filter Tube
434 px 51.57597 $ Back End of Beam Filter Tube
c
c ----- North Beam Assembly -----
531 py 17.33395 $ Core Face of West Beam Filter Tube
532 px -6.985 $ East Surface of West Beam Filter Tube
533 px 6.985 $ West Surface of West Beam Filter Tube
534 py 52.54498 $ Back End of Beam Filter Tube
c
c --- Dry Tube -----
c ----- Horizontal Planes -----
600 pz 70.08876 $ Inside Bottom of Dry Tube
c
c ----- Radii -----
651 c/z -18.134965 -17.548225 2.301875 $ Dry Tube Outer Surface
652 c/z -18.134965 -17.548225 1.984375 $ Dry Tube Inner Surface
c
c Data Cards *****
c
c *** Material Cards *****
c --- Water -----
m1 1001.70c 6.6611E-02 1002.70c 7.6612E-06 8016.70c 3.3297E-02
8017.70c 1.2658E-05
c Total 9.9928E-02
mt1 lwtr.10t hwtr.10t
c
c --- Fuel Rods (Non-Fuel Components) -----
c ----- Axial Graphite Reflectors -----
m2 6000.70c 8.6734E-02
c Total 8.6734E-02
mt2 grph.10t
c
c ----- Moly Poison Disc -----
m3 42092.70c 9.5169E-03 42094.70c 5.9320E-03 42095.70c 1.0210E-02
42096.70c 1.0697E-02 42097.70c 6.1244E-03 42098.70c 1.5475E-02
42100.70c 6.1757E-03
c Total 6.4130E-02
c
c ----- Zr Rod -----
m4 40090.70c 2.2070E-02 40091.70c 4.8130E-03 40092.70c 7.3568E-03
40094.70c 7.4555E-03 40096.70c 1.2011E-03
c Total 4.2897E-02
c

```

Fundamental - FUND

NRAD-FUND-RESR-001
CRIT-REAC-COEF

```

c ----- SS 304 Claddings and End Fittings -----
m5  6000.70c 1.6044E-04 14028.70c 6.3283E-04 14029.70c 3.2134E-05
    14030.70c 2.1183E-05 15031.70c 4.0441E-05 16032.70c 3.1374E-06
    16033.70c 2.5117E-08 16034.70c 1.4178E-07 16036.70c 6.6099E-10
    24050.70c 7.6491E-04 24052.70c 1.4751E-02 24053.70c 1.6726E-03
    24054.70c 4.1634E-04 25055.70c 8.7693E-04 26054.70c 3.4644E-03
    26056.70c 5.4383E-02 26057.70c 1.2559E-03 26058.70c 1.6714E-04
    28058.70c 5.5882E-03 28060.70c 2.1526E-03 28061.70c 9.3571E-05
    28062.70c 2.9834E-04 28064.70c 7.5980E-05
c    Total      8.6851E-02
mt5  fe56.12t
c
c --- Control Rods -----
c ----- B4C Absorber -----
m6  5010.70c 2.1515E-02 5011.70c 8.6601E-02 6000.70c 2.7029E-02
c    Total      1.3514E-01
mt6  grph.10t
c
c ----- Al 6061 Claddings and End Fittings -----
m7  13027.70c 5.8593E-02
c    Total      5.8593E-02
mt7  al27.12t
c
c --- Graphite Reflector Assemblies -----
c ----- Graphite Reflectors -----
m8  6000.70c 7.8692E-02
c    Total      7.8692E-02
mt8  grph.10t
c
c ----- 60-Rod-Average UErZrH Fuel Rod Composition -----
m9  92234.70c 9.9323E-06 92235.70c 1.0844E-03 92236.70c 1.2036E-05
    92238.70c 4.3326E-03 5010.70c 7.6277E-08 5011.70c 3.0702E-07
    1001.70c 5.0608E-02 1002.70c 5.8206E-06 6000.70c 1.0781E-03
    40090.70c 1.6481E-02 40091.70c 3.5940E-03 40092.70c 5.4936E-03
    40094.70c 5.5672E-03 40096.70c 8.9691E-04 68162.70c 3.2517E-07
    68164.70c 3.7395E-06 68166.70c 7.8064E-05 68167.70c 5.3258E-05
    68168.70c 6.2200E-05 68170.70c 3.4677E-05 72174.70c 1.3203E-09
    72176.70c 4.3403E-08 72177.70c 1.5348E-07 72178.70c 2.2510E-07
    72179.70c 1.1239E-07 72180.70c 2.8947E-07
c    Total      8.9397E-02
mt9  h/zr.10t zr/h.10t
c
c
c *** Control Cards *****
mode n
kcode 100000 1 50 1550
ksrc -1.9431 -1.9431 96.6 1.9431 1.9431 96.6
      -5.8293 5.8293 96.6 5.8293 -5.8293 96.6
      -9.7155 -9.7155 96.6 9.7155 9.7155 96.6
      -13.6017 13.6017 96.6 13.6017 -13.6017 96.6
      -13.6017 0.0 96.6 13.6017 0.0 96.6
      0.0 13.6017 96.6 0.0 -13.6017 96.6
print
kopts blocksize=10 kinetics=yes precursor=yes
c

```

A.5 Reactivity Coefficient Configurations

Reactivity coefficient measurements have not been evaluated.

A.6 Kinetics Parameter Configurations

Kinetics measurements were not made.

A.7 Reaction-Rate Configurations

Reaction-rate distribution measurements were not made.

A.8 Power Distribution Configurations

Power distribution measurements were not made.

A.9 Isotopic Configurations

Isotopic measurements were not made.

A.10 Configurations of Other Miscellaneous Types of Measurements

Other miscellaneous types of measurements were not made.

APPENDIX B: CALCULATED SPECTRAL DATA

The neutron spectral calculations provided below were obtained from the output files for the input decks provided in Appendix A.1 and results in Section 4.1. Only spectral data using the ENDF/B-VII.0, JEFF-3.1, and JENDL-3.3 neutron cross section libraries are provided here for the MCNP5 analyses and the ENDF/B-VII.0 (238-group and continuous energy) library for the KENO analyses. The cross sections are all continuous in the MCNP5 analyses.

B.1 MCNP-Calculated Spectral Data

A summary of the computed neutron spectral data using MCNP5 for the benchmark models is provided in Table B.1.

Table B.1a. Neutron Spectral Data for Benchmark Model Case 1 (MCNP5).

Neutron Cross Section Library	ENDF/B-VII.0	JEFF-3.1	JENDL-3.3	ENDF/B-VI.8
k_{eff}	1.00906	1.00712	1.00616	1.00437
$\pm\sigma_k$	0.00007	0.00007	0.00007	0.00007
Neutron Balance (%)^(a)				
Leakage	2.28	2.26	2.28	2.28
Capture (x, xn)	56.43	56.52	56.53	56.61
Fission	41.25	41.18	41.16	41.06
Fission Fraction, by Energy (%)				
Thermal (<0.625 eV)	80.75	80.79	80.74	80.70
Intermediate	16.27	16.24	16.24	16.27
Fast (>100 keV)	2.98	2.97	3.01	3.03
Fission Fraction, by Isotope (%)				
²³⁴ U	0.01	0.01	0.01	0.01
²³⁵ U	98.74	98.74	98.73	98.71
²³⁶ U	0.01	0.01	0.01	0.01
²³⁸ U	1.23	1.23	1.24	1.26
Average Number of Neutrons Produced per Fission	2.444	2.443	2.443	2.444
Energy of Average Neutron Lethargy Causing Fission (eV)	0.26275	0.26268	0.26363	0.27350
Neutron Generation Time, Λ (msec)	27.28211	27.68848	27.61620	27.76216
$\pm\sigma_\Lambda$	0.08941	0.09297	0.09132	0.09277
Rossi-α (msec⁻¹)	-2.746E-04	-2.707E-04	-2.754E-04	-2.652E-04
$\pm\sigma_R$	4.205E-06	4.156E-06	4.200E-06	4.067E-06
β_{eff}	0.00738	0.00763	0.00732	0.00778
$\pm\sigma_\beta$	0.00011	0.00011	0.00011	0.00011

(a) The neutron balance is calculated using the neutron balance tables provided in the MCNP output file. The weight fraction of neutrons lost due to a given event are divided by the total neutron loss of those events reported here.

Table B.1b. Neutron Spectral Data for Benchmark Model Case 2 (MCNP5).

Neutron Cross Section Library	ENDF/B-VII.0	JEFF-3.1	JENDL-3.3	ENDF/B-VI.8
k_{eff}	1.01029	1.00822	1.00731	1.00558
$\pm\sigma_k$	0.00007	0.00007	0.00007	0.00007
Neutron Balance (%)^(a)				
Leakage	2.39	2.37	2.39	2.40
Capture (x, xn)	56.27	56.36	56.36	56.44
Fission	41.30	41.22	41.20	41.11
Fission Fraction, by Energy (%)				
Thermal (<0.625 eV)	80.54	80.57	80.52	80.48
Intermediate	16.46	16.43	16.44	16.46
Fast (>100 keV)	3.00	3.00	3.04	3.06
Fission Fraction, by Isotope (%)				
²³⁴ U	0.01	0.01	0.01	0.01
²³⁵ U	98.73	98.73	98.72	98.70
²³⁶ U	0.01	0.01	0.01	0.01
²³⁸ U	1.24	1.24	1.25	1.27
Average Number of Neutrons Produced per Fission	2.444	2.444	2.443	2.444
Energy of Average Neutron Lethargy Causing Fission (eV)	0.26810	0.26804	0.26913	0.27914
Neutron Generation Time, Λ (msec)	26.38950	26.49562	26.47514	26.81460
$\pm\sigma_\Lambda$	0.08936	0.08837	0.08942	0.09016
Rossi-α (msec⁻¹)	-2.775E-04	-2.863E-04	-2.792E-04	-2.884E-04
$\pm\sigma_R$	4.253E-06	4.310E-06	4.249E-06	4.274E-06
β_{eff}	0.00732	0.00759	0.00739	0.00773
$\pm\sigma_\beta$	0.00011	0.00011	0.00011	0.00011

(b) The neutron balance is calculated using the neutron balance tables provided in the MCNP output file. The weight fraction of neutrons lost due to a given event are divided by the total neutron loss of those events reported here.

B.2 KENO-Calculated Spectral Data

A summary of the computed neutron spectral data using KENO-VI for the benchmark model is provided in Table B.2.

Table B.2a. Neutron Spectral Data for Benchmark Model Case 1 (KENO).

Neutron Cross Section Library	ENDF/B-VII.0 (238-group)	ENDF/B-VII.0 (continuous energy)
k_{eff}	1.009005	1.004329
$\pm\sigma_k$	0.000066	0.000077
Energy of Average Neutron Lethargy Causing Fission (eV)	0.25341	0.27061
$\pm\sigma_{\text{EALF}}$	0.00003	0.00007
Average Number of Neutrons Produced per Fission	2.44384	2.44390
$\pm\sigma_v$	<0.00001	<0.00001
Mean Free Path (cm)	0.68757	0.68908
$\pm\sigma_\lambda$	0.00003	0.00003

Table B.2b. Neutron Spectral Data for Benchmark Model Case 2 (KENO).

Neutron Cross Section Library	ENDF/B-VII.0 (238-group)	ENDF/B-VII.0 (continuous energy)
k_{eff}	1.010411	1.005504
$\pm\sigma_k$	0.000069	0.000081
Energy of Average Neutron Lethargy Causing Fission (eV)	0.25849	0.27618
$\pm\sigma_{\text{EALF}}$	0.00003	0.00007
Average Number of Neutrons Produced per Fission	2.44391	2.44396
$\pm\sigma_v$	<0.00001	<0.00001
Mean Free Path (cm)	0.68752	0.68901
$\pm\sigma_\lambda$	0.00003	0.00003

APPENDIX C: DETAILED MODEL INPUT DECKS**C.1 Detailed MCNP Models of the NRAD Reactor**

Detailed models of the NRAD reactor core configurations were prepared to evaluate biases in the benchmark models. Because the effects of many of the model simplifications produced small or otherwise negligible biases (in regards to criticality) in the benchmark model, development of a detailed benchmark model was unnecessary. The MCNP5 input decks, using ENDF/B-VII.0 neutron cross section data, is preserved in this appendix for future use. Calculations were performed with 1,550 generations with 100,000 neutrons per generation. The k_{eff} estimates did not include the first 50 generations and are the result of 150,000,000 neutron histories. Calculated results obtained with this input deck are provided in Table C.1. Figures C.1 through C.5 provide various views of the complexity incorporated into the detailed model.

This model uses a tank water temperature of 26.0 °C (0.9968 g/cm³) for both configurations.

Table C.1. Neutron Spectral Data for Detailed Models.

Case	1	2	
# Fuel Elements	56	60	
Neutron Cross Section Library	ENDF/B-VII.0	ENDF/B-VII.0	
k_{eff}	1.00765	1.00934	
$\pm\sigma_k$	0.00007	0.00007	
Neutron Balance (%) ^(a)	Leakage	0.03	0.04
	Capture (x, xn)	58.73	58.66
		0.05	0.05
	Fission	41.19	41.26
Fission Fraction, by Energy (%)	Thermal (<0.625 eV)	80.58	80.38
	Intermediate	16.42	16.60
	Fast (>100 keV)	2.99	3.02
Fission Fraction, by Isotope (%)	²³⁴ U	0.01	0.01
	²³⁵ U	98.74	98.73
	²³⁶ U	0.01	0.01
	²³⁸ U	1.24	1.25
Average Number of Neutrons Produced per Fission	2.444	2.444	
Energy of Average Neutron Lethargy Causing Fission (eV)	0.26679	0.27191	
Neutron Generation Time, Λ (msec)	26.88786	25.89185	
$\pm\sigma_\Lambda$	0.08921	0.08703	
Rossi- α (msec ⁻¹)	-2.746E-04	-2.952E-04	
$\pm\sigma_R$	4.205E-06	4.410E-06	
β_{eff}	0.00738	0.00764	
$\pm\sigma_\beta$	0.00011	0.00011	

(a) The neutron balance is calculated using the neutron balance tables provided in the MCNP output file. The weight fraction of neutrons lost due to a given event are divided by the total neutron loss of those events reported here.

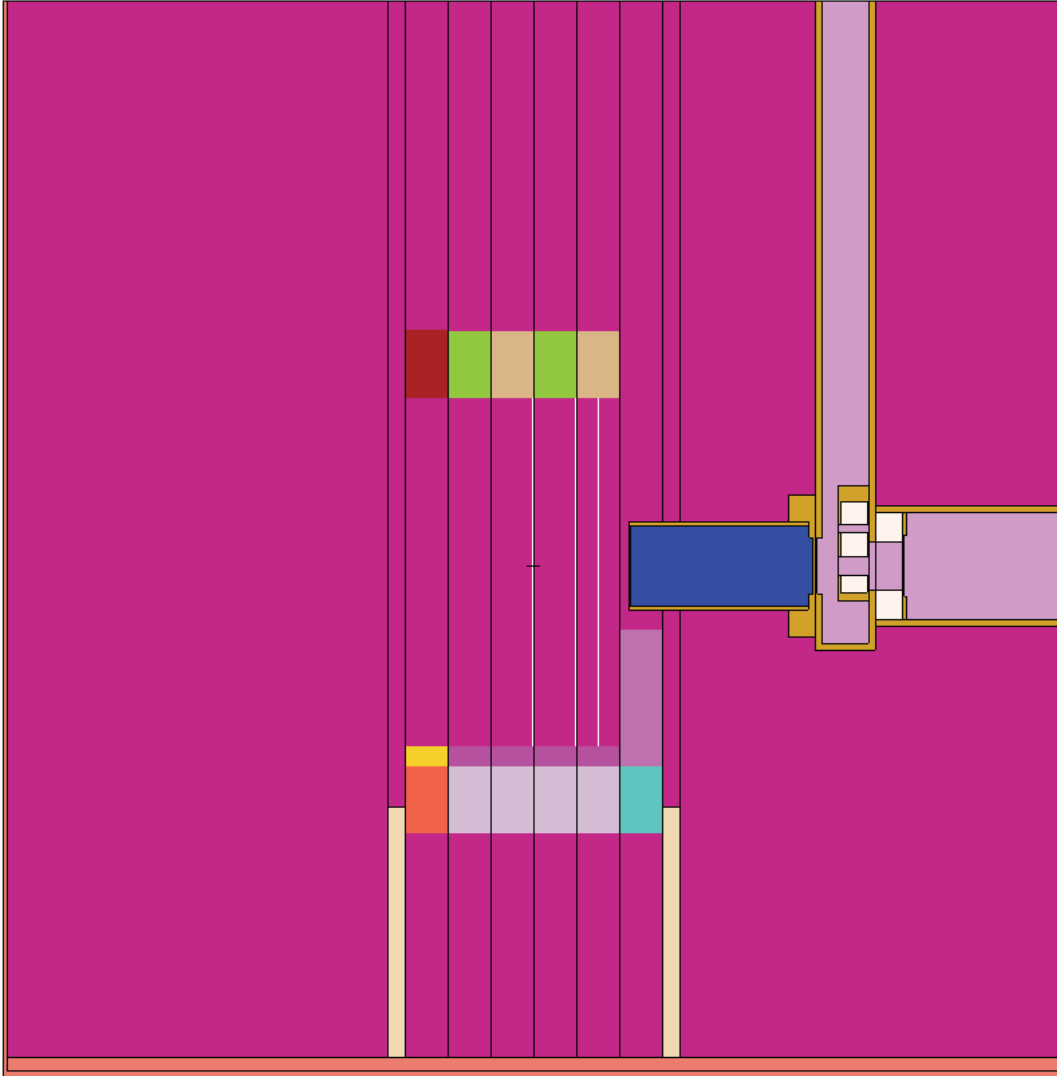

Figure C.1. Vertical Cross Section of Detailed NRAD Model.

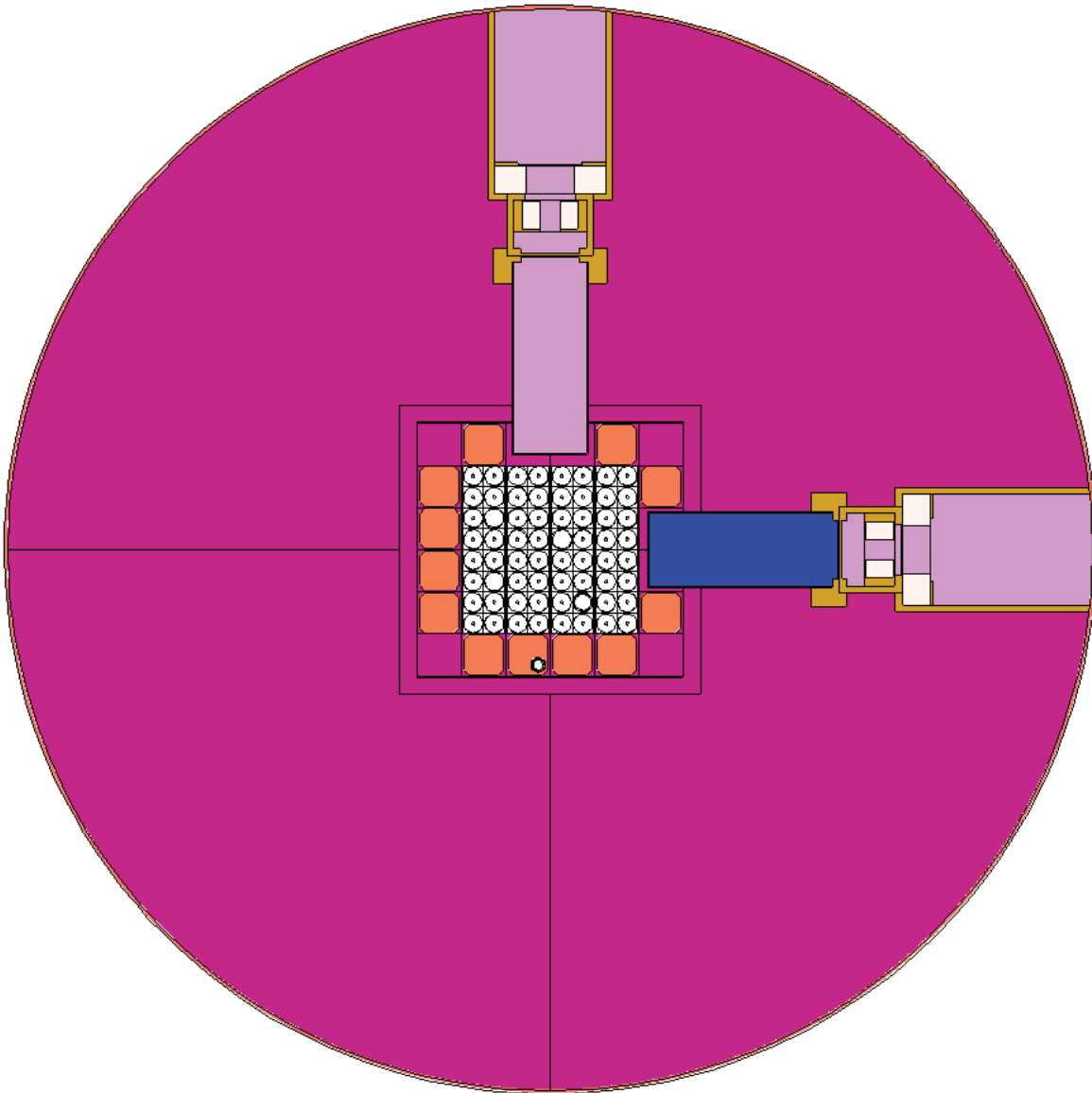

Figure C.2. Horizontal Cross Section of Detailed NRAD Model at Fuel Midplane (60-Fuel-Element Core).

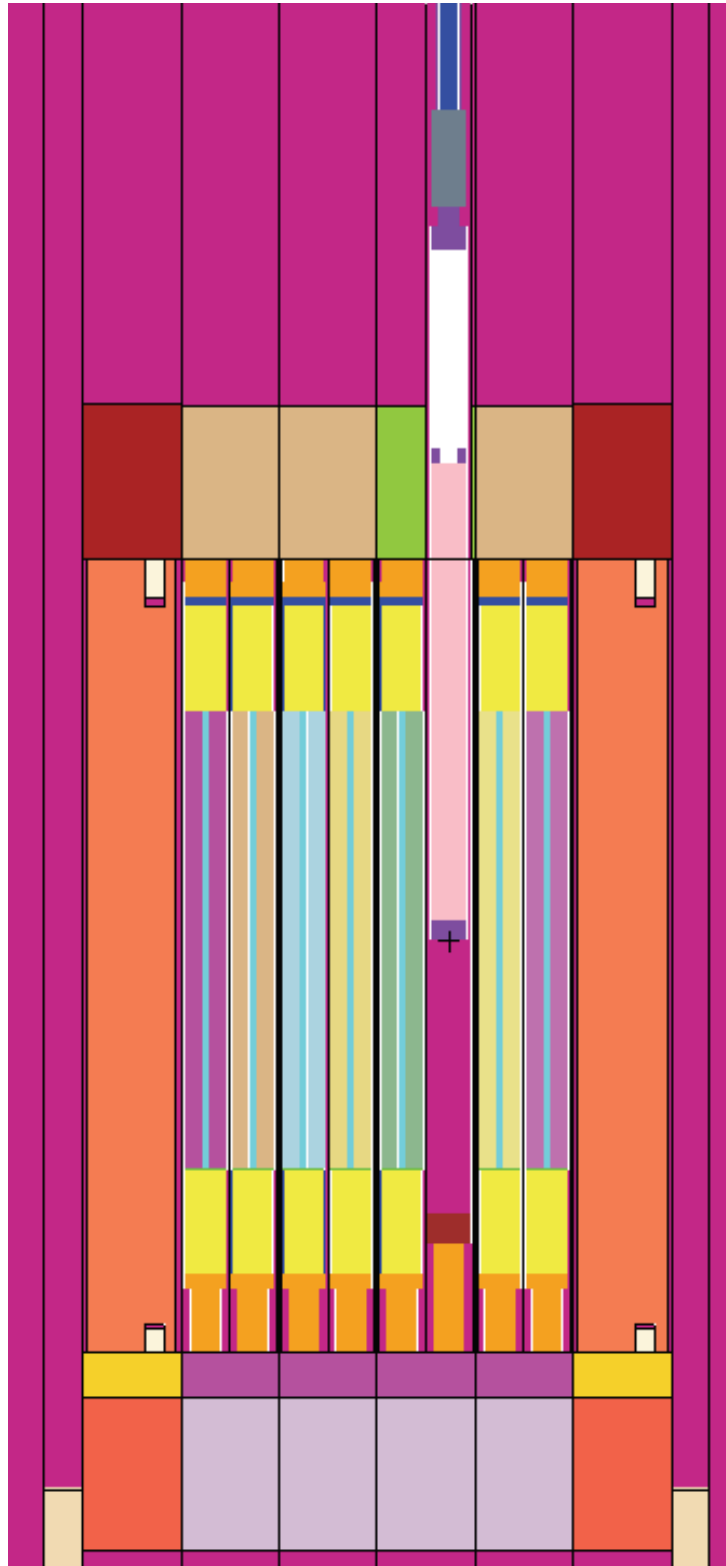

Figure C.3. Fuel Element and Reg Rod View of Detailed NRAD Model.

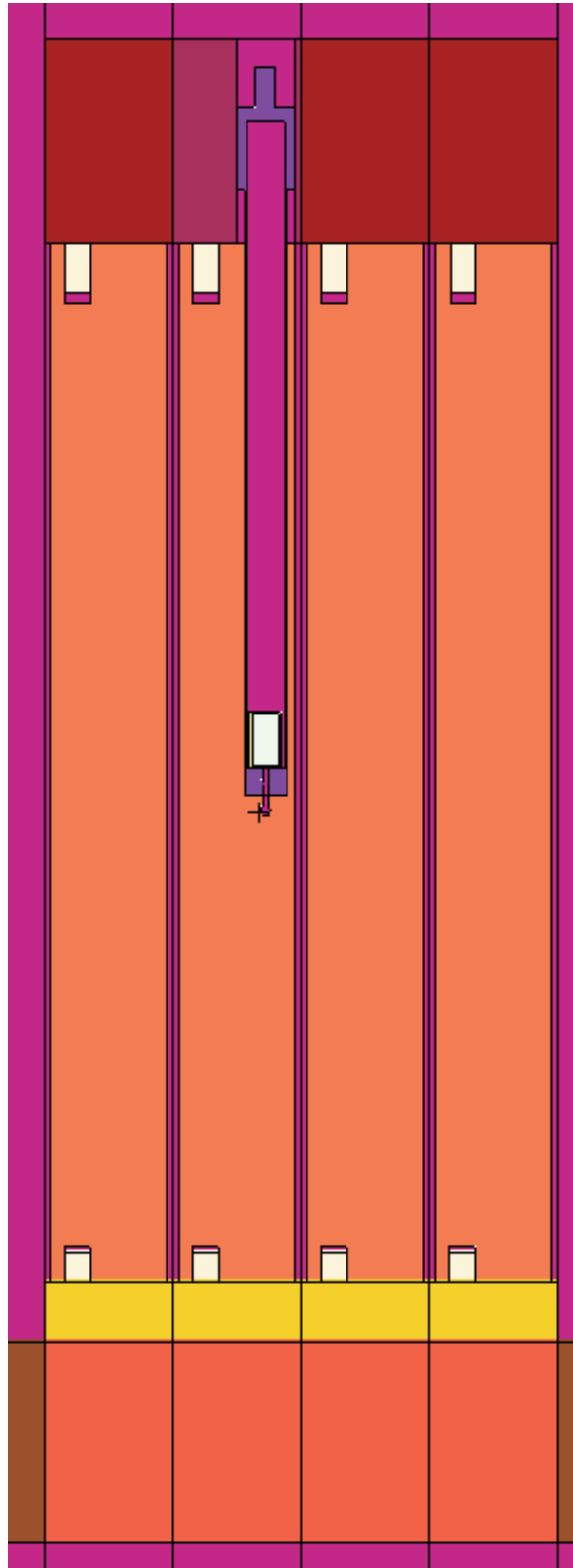

Figure C.4. Graphite Block and AmBe Source View of Detailed NRAD Model.

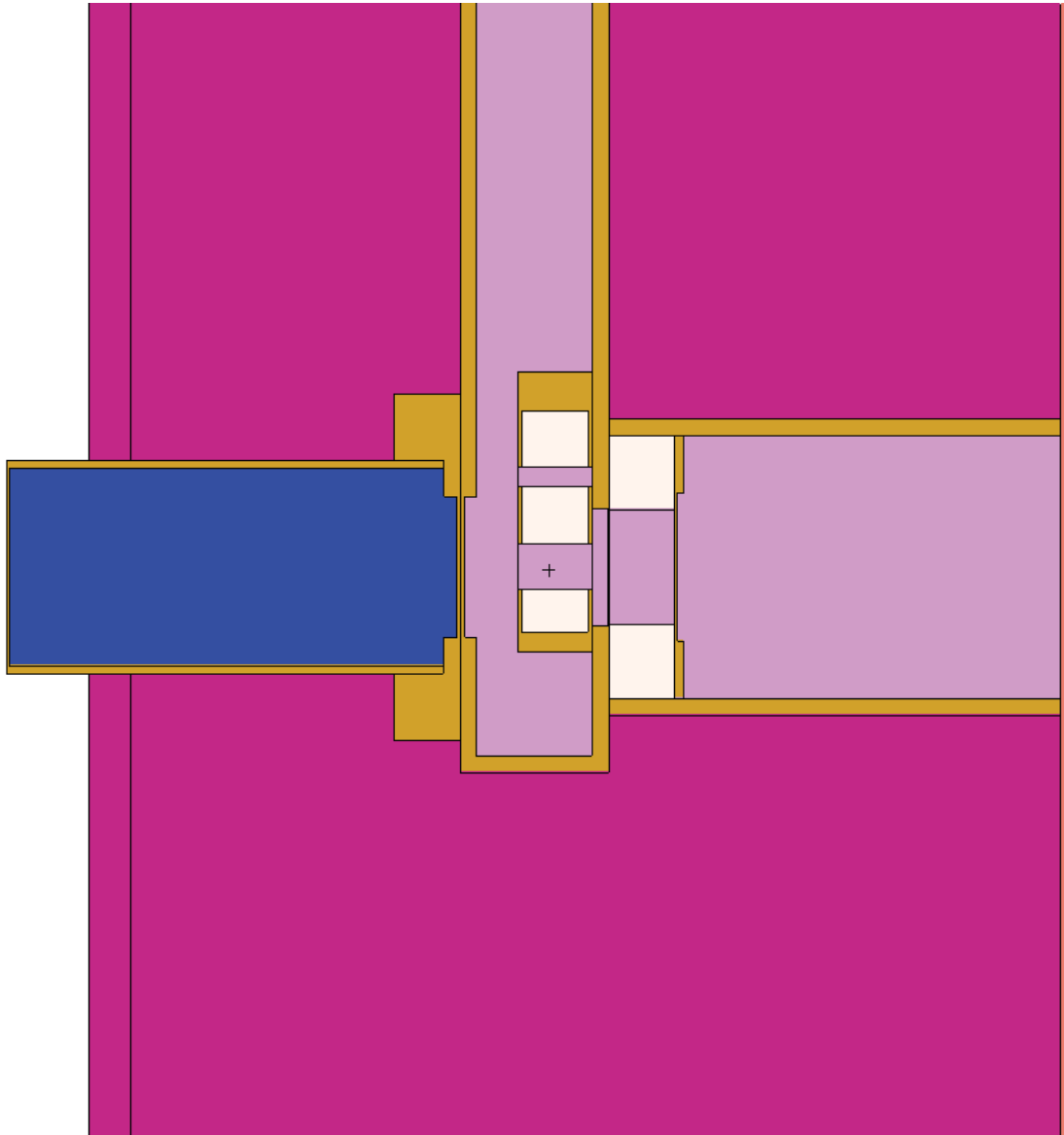

Figure C.5. East Beam Line View of Detailed NRAD Model.

C.2 Input Listing for Detailed Models*MCNP5 Input Deck for the 56-fuel-element initial core configuration (Case 1):*

```

INITIAL CRITICAL OF THE NRAD REACTOR WITH U(20)-ER-ZR-H FUEL (DETAILED)
c
c John Darrell Bess - Idaho National Laboratory
c Last Updated: January 3, 2012
c
c Cell Cards *****
c --- Control Rod Positions -----
1415 0 202 -252 imp:n=1 u=1402 fill=1406 (0 0 38.1) $ Shim 2 Control Rod
2035 0 202 -252 imp:n=1 u=2004 fill=2006 (0 0 38.1) $ Shim 1 Control Rod
2815 0 202 -252 imp:n=1 u=2802 fill=2806 (0 0 29.5275) $ Reg Control Rod
c
c * Control Rods are fully inserted when the values in parenthesis are (0 0 0) *
c * Control Rods are fully withdrawn when the values are (0 0 38.1), which *
c * corresponds to 1000 units withdrawn *
c
c --- Assemblies -----
c ----- Position A-1 : Empty Position -----
101 1 9.9961E-02 -5 imp:n=1 u=100 $ Water Below Grid Plate
102 61 8.0867E-02 5 -7 imp:n=1 u=100 $ Empty Grid Plate Position
103 1 9.9961E-02 7 imp:n=1 u=100 $ Water Above Core
c
c ----- Position A-2 : Graphite Reflector -----
201 1 9.9961E-02 -5 imp:n=1 u=200 $ Water Below Grid Plate
203 63 6.9890E-02 5 -7 imp:n=1 u=200 $ Grid Plate With Adapter
204 44 7.6788E-02 7 -9 imp:n=1 u=200 $ Lower Adapter
205 41 7.8699E-02 (9 -10) (-9:303:354) (-9:303:355) (-9:305:351) (-306:10:356)
(-306:10:357) (331 -332 333 -334) (-335 -336 -337 -338)
imp:n=1 u=200 $ Graphite Block
206 42 6.0307E-02 307 -10 -356 imp:n=1 u=200 $ Top Screw NE
207 42 6.0307E-02 307 -10 -357 imp:n=1 u=200 $ Top Screw SW
208 1 9.9961E-02 306 -307 -356 imp:n=1 u=200 $ Water in NE Top Hole
209 1 9.9961E-02 306 -307 -357 imp:n=1 u=200 $ Water in SW Top Hole
210 42 6.0307E-02 9 -302 -352 imp:n=1 u=200 $ Bottom Dowel NE
211 42 6.0307E-02 9 -302 -353 imp:n=1 u=200 $ Bottom Dowel SW
212 42 6.0307E-02 9 -304 -351 imp:n=1 u=200 $ Tie Rod
213 1 9.9961E-02 (9 -303 352 -354):(302 -303 -354) imp:n=1 u=200 $ Water in NE Bottom Hole
214 1 9.9961E-02 (9 -303 353 -355):(302 -303 -355) imp:n=1 u=200 $ Water in SW Bottom Hole
215 1 9.9961E-02 (304 -305 -351) imp:n=1 u=200 $ Water in Tie Rod Hole
216 43 9.1820E-02 10 -309 imp:n=1 u=200 $ Upper Assembly
217 1 9.9961E-02 309 imp:n=1 u=200 $ Water Above Core
218 1 9.9961E-02 (9 -10) (-331:332:-333:334:335:336:337:338) imp:n=1 u=200 $ Water Around
Assembly
c
c ----- Position A-3 : North Beam Tube Support -----
301 1 9.9961E-02 -5 imp:n=1 u=300 $ Water Below Grid Plate
303 64 7.5685E-02 5 -7 imp:n=1 u=300 $ Grid Plate With Support
304 51 9.1752E-02 7 -401 imp:n=1 u=300 $ Beam Tube Support
305 1 9.9961E-02 401 imp:n=1 u=300 $ Water Above Support
c
c ----- Position A-4 : North Beam Tube Support -----
401 1 9.9961E-02 -5 imp:n=1 u=400 $ Water Below Grid Plate
403 64 7.5685E-02 5 -7 imp:n=1 u=400 $ Grid Plate With Support
404 51 9.1752E-02 7 -401 imp:n=1 u=400 $ Beam Tube Support
405 1 9.9961E-02 401 imp:n=1 u=400 $ Water Above Support
c
c ----- Position A-5 : Empty Position -----
501 1 9.9961E-02 -5 imp:n=1 u=500 $ Water Below Grid Plate
502 61 8.0867E-02 5 -7 imp:n=1 u=500 $ Empty Grid Plate Position
503 1 9.9961E-02 7 imp:n=1 u=500 $ Water Above Core
c
c ----- Position A-6 : Empty Position -----
601 1 9.9961E-02 -5 imp:n=1 u=600 $ Water Below Grid Plate
602 61 8.0867E-02 5 -7 imp:n=1 u=600 $ Empty Grid Plate Position
603 1 9.9961E-02 7 imp:n=1 u=600 $ Water Above Core
c
c ----- Position B-1 : Graphite Reflector -----
701 1 9.9961E-02 -5 imp:n=1 u=700 $ Water Below Grid Plate
703 63 6.9890E-02 5 -7 imp:n=1 u=700 $ Grid Plate With Adapter
704 44 7.6788E-02 7 -9 imp:n=1 u=700 $ Lower Adapter
705 41 7.8699E-02 (9 -10) (-9:303:354) (-9:303:355) (-9:305:351) (-306:10:356)

```

Fundamental - FUND

NRAD-FUND-RESR-001
CRIT-REAC-COEF

```

(-306:10:357) (331 -332 333 -334) (-335 -336 -337 -338)
imp:n=1 u=700 $ Graphite Block
706 42 6.0307E-02 307 -10 -356 imp:n=1 u=700 $ Top Screw NE
707 42 6.0307E-02 307 -10 -357 imp:n=1 u=700 $ Top Screw SW
708 1 9.9961E-02 306 -307 -356 imp:n=1 u=700 $ Water in NE Top Hole
709 1 9.9961E-02 306 -307 -357 imp:n=1 u=700 $ Water in SW Top Hole
710 42 6.0307E-02 9 -302 -352 imp:n=1 u=700 $ Bottom Dowel NE
711 42 6.0307E-02 9 -302 -353 imp:n=1 u=700 $ Bottom Dowel SW
712 42 6.0307E-02 9 -304 -351 imp:n=1 u=700 $ Tie Rod
713 1 9.9961E-02 (9 -303 352 -354):(302 -303 -354) imp:n=1 u=700 $ Water in NE Bottom Hole
714 1 9.9961E-02 (9 -303 353 -355):(302 -303 -355) imp:n=1 u=700 $ Water in SW Bottom Hole
715 1 9.9961E-02 (304 -305 -351) imp:n=1 u=700 $ Water in Tie Rod Hole
716 43 9.1820E-02 10 -309 imp:n=1 u=700 $ Upper Assembly
717 1 9.9961E-02 309 imp:n=1 u=700 $ Water Above Core
718 1 9.9961E-02 (9 -10) (-331:332:-333:334:335:336:337:338) imp:n=1 u=700 $ Water Around
Assembly
c
c ----- Position B-2 : 4-Rod Fuel Cluster -----
c ----- NW Fuel Rod : 11810 -----
801 14 8.7412E-02 (-103 -151):(102 -103 -156) imp:n=1 u=801 $ Bottom End Fitting
802 11 8.6735E-02 103 -104 -152 imp:n=1 u=801 $ Bottom Graphite Reflector
803 12 6.4196E-02 104 -105 -153 imp:n=1 u=801 $ Moly Poison Disc
804 13 4.3026E-02 105 -106 -154 imp:n=1 u=801 $ Zirconium Rod
870 2 5.0820E-05 105 -106 154 -159 imp:n=1 u=801 $ Zr/Fuel Gap
805 159 8.9626E-02 105 -106 159 -155 imp:n=1 u=801 $ Fuel Rod
806 11 8.6735E-02 106 -107 -152 imp:n=1 u=801 $ Top Graphite Reflector
807 2 5.0820E-05 (-103:104:152) (-104:105:153) (-105:106:155)
(-106:107:152) (103 -108 -156) imp:n=1 u=801 $ Air Gap
808 14 8.7412E-02 102 -109 156 -157 imp:n=1 u=801 $ Cladding
809 14 8.7412E-02 (108 -158):(108 -109 -156) imp:n=1 u=801 $ Top End Fitting
810 1 9.9961E-02 157:(-102 151):(109 158) imp:n=1 u=801 $ Water
c
c ----- NE Fuel Rod : 11811 -----
811 14 8.7412E-02 (-103 -151):(102 -103 -156) imp:n=1 u=802 $ Bottom End Fitting
812 11 8.6735E-02 103 -104 -152 imp:n=1 u=802 $ Bottom Graphite Reflector
813 12 6.4196E-02 104 -105 -153 imp:n=1 u=802 $ Moly Poison Disc
814 13 4.3026E-02 105 -106 -154 imp:n=1 u=802 $ Zirconium Rod
871 2 5.0820E-05 105 -106 154 -159 imp:n=1 u=802 $ Zr/Fuel Gap
815 160 9.0182E-02 105 -106 159 -155 imp:n=1 u=802 $ Fuel Rod
816 11 8.6735E-02 106 -107 -152 imp:n=1 u=802 $ Top Graphite Reflector
817 2 5.0820E-05 (-103:104:152) (-104:105:153) (-105:106:155)
(-106:107:152) (103 -108 -156) imp:n=1 u=802 $ Air Gap
818 14 8.7412E-02 102 -109 156 -157 imp:n=1 u=802 $ Cladding
819 14 8.7412E-02 (108 -158):(108 -109 -156) imp:n=1 u=802 $ Top End Fitting
820 1 9.9961E-02 157:(-102 151):(109 158) imp:n=1 u=802 $ Water
c
c ----- SW Fuel Rod : 11809 -----
821 14 8.7412E-02 (-103 -151):(102 -103 -156) imp:n=1 u=803 $ Bottom End Fitting
822 11 8.6735E-02 103 -104 -152 imp:n=1 u=803 $ Bottom Graphite Reflector
823 12 6.4196E-02 104 -105 -153 imp:n=1 u=803 $ Moly Poison Disc
824 13 4.3026E-02 105 -106 -154 imp:n=1 u=803 $ Zirconium Rod
872 2 5.0820E-05 105 -106 154 -159 imp:n=1 u=803 $ Zr/Fuel Gap
825 158 8.9820E-02 105 -106 159 -155 imp:n=1 u=803 $ Fuel Rod
826 11 8.6735E-02 106 -107 -152 imp:n=1 u=803 $ Top Graphite Reflector
827 2 5.0820E-05 (-103:104:152) (-104:105:153) (-105:106:155)
(-106:107:152) (103 -108 -156) imp:n=1 u=803 $ Air Gap
828 14 8.7412E-02 102 -109 156 -157 imp:n=1 u=803 $ Cladding
829 14 8.7412E-02 (108 -158):(108 -109 -156) imp:n=1 u=803 $ Top End Fitting
830 1 9.9961E-02 157:(-102 151):(109 158) imp:n=1 u=803 $ Water
c
c ----- SE Fuel Rod : 11808 -----
831 14 8.7412E-02 (-103 -151):(102 -103 -156) imp:n=1 u=804 $ Bottom End Fitting
832 11 8.6735E-02 103 -104 -152 imp:n=1 u=804 $ Bottom Graphite Reflector
833 12 6.4196E-02 104 -105 -153 imp:n=1 u=804 $ Moly Poison Disc
834 13 4.3026E-02 105 -106 -154 imp:n=1 u=804 $ Zirconium Rod
873 2 5.0820E-05 105 -106 154 -159 imp:n=1 u=804 $ Zr/Fuel Gap
835 157 8.9348E-02 105 -106 159 -155 imp:n=1 u=804 $ Fuel Rod
836 11 8.6735E-02 106 -107 -152 imp:n=1 u=804 $ Top Graphite Reflector
837 2 5.0820E-05 (-103:104:152) (-104:105:153) (-105:106:155)
(-106:107:152) (103 -108 -156) imp:n=1 u=804 $ Air Gap
838 14 8.7412E-02 102 -109 156 -157 imp:n=1 u=804 $ Cladding
839 14 8.7412E-02 (108 -158):(108 -109 -156) imp:n=1 u=804 $ Top End Fitting
840 1 9.9961E-02 157:(-102 151):(109 158) imp:n=1 u=804 $ Water
c
c ----- Fuel Assembly -----
841 1 9.9961E-02 -5 imp:n=1 u=800 $ Water Below Grid Plate

```

Fundamental - FUND

NRAD-FUND-RESR-001
CRIT-REAC-COEF

```

843 62 7.4744E-02 5 -7 imp:n=1 u=800 $ Grid Plate With Adapter
844 33 7.7699E-02 7 -9 imp:n=1 u=800 $ Lower Adapter
845 1 9.9961E-02 -132 131 -134 133 imp:n=1 u=805 lat=1 fill=-1:2 -1:2 0:0 $ Fuel Assemblies
      805 805 805 805
      805 803 804 805
      805 801 802 805
      805 805 805 805
846 0 9 -10 imp:n=1 u=800 fill=805 (-1.9431 -1.9431 0) $ Fuel Bundle
847 31 9.3070E-02 10 -12 imp:n=1 u=800 $ Upper Assembly
848 1 9.9961E-02 12 imp:n=1 u=800 $ Water Above Core
c
c ----- Position B-3 : 4-Rod Fuel Cluster -----
c ----- NW Fuel Rod : 11776 -----
901 14 8.7412E-02 (-103 -151):(102 -103 -156) imp:n=1 u=901 $ Bottom End Fitting
902 11 8.6735E-02 103 -104 -152 imp:n=1 u=901 $ Bottom Graphite Reflector
903 12 6.4196E-02 104 -105 -153 imp:n=1 u=901 $ Moly Poison Disc
904 13 4.3026E-02 105 -106 -154 imp:n=1 u=901 $ Zirconium Rod
970 2 5.0820E-05 105 -106 154 -159 imp:n=1 u=901 $ Zr/Fuel Gap
905 125 8.9953E-02 105 -106 159 -155 imp:n=1 u=901 $ Fuel Rod
906 11 8.6735E-02 106 -107 -152 imp:n=1 u=901 $ Top Graphite Reflector
907 2 5.0820E-05 (-103:104:152) (-104:105:153) (-105:106:155)
      (-106:107:152) (103 -108 -156) imp:n=1 u=901 $ Air Gap
908 14 8.7412E-02 102 -109 156 -157 imp:n=1 u=901 $ Cladding
909 14 8.7412E-02 (108 -158):(108 -109 -156) imp:n=1 u=901 $ Top End Fitting
910 1 9.9961E-02 157:(-102 151):(109 158) imp:n=1 u=901 $ Water
c
c ----- NE Fuel Rod : 11777 -----
911 14 8.7412E-02 (-103 -151):(102 -103 -156) imp:n=1 u=902 $ Bottom End Fitting
912 11 8.6735E-02 103 -104 -152 imp:n=1 u=902 $ Bottom Graphite Reflector
913 12 6.4196E-02 104 -105 -153 imp:n=1 u=902 $ Moly Poison Disc
914 13 4.3026E-02 105 -106 -154 imp:n=1 u=902 $ Zirconium Rod
971 2 5.0820E-05 105 -106 154 -159 imp:n=1 u=902 $ Zr/Fuel Gap
915 126 8.9487E-02 105 -106 159 -155 imp:n=1 u=902 $ Fuel Rod
916 11 8.6735E-02 106 -107 -152 imp:n=1 u=902 $ Top Graphite Reflector
917 2 5.0820E-05 (-103:104:152) (-104:105:153) (-105:106:155)
      (-106:107:152) (103 -108 -156) imp:n=1 u=902 $ Air Gap
918 14 8.7412E-02 102 -109 156 -157 imp:n=1 u=902 $ Cladding
919 14 8.7412E-02 (108 -158):(108 -109 -156) imp:n=1 u=902 $ Top End Fitting
920 1 9.9961E-02 157:(-102 151):(109 158) imp:n=1 u=902 $ Water
c
c ----- SW Fuel Rod : 11778 -----
921 14 8.7412E-02 (-103 -151):(102 -103 -156) imp:n=1 u=903 $ Bottom End Fitting
922 11 8.6735E-02 103 -104 -152 imp:n=1 u=903 $ Bottom Graphite Reflector
923 12 6.4196E-02 104 -105 -153 imp:n=1 u=903 $ Moly Poison Disc
924 13 4.3026E-02 105 -106 -154 imp:n=1 u=903 $ Zirconium Rod
972 2 5.0820E-05 105 -106 154 -159 imp:n=1 u=903 $ Zr/Fuel Gap
925 127 8.9490E-02 105 -106 159 -155 imp:n=1 u=903 $ Fuel Rod
926 11 8.6735E-02 106 -107 -152 imp:n=1 u=903 $ Top Graphite Reflector
927 2 5.0820E-05 (-103:104:152) (-104:105:153) (-105:106:155)
      (-106:107:152) (103 -108 -156) imp:n=1 u=903 $ Air Gap
928 14 8.7412E-02 102 -109 156 -157 imp:n=1 u=903 $ Cladding
929 14 8.7412E-02 (108 -158):(108 -109 -156) imp:n=1 u=903 $ Top End Fitting
930 1 9.9961E-02 157:(-102 151):(109 158) imp:n=1 u=903 $ Water
c
c ----- SE Fuel Rod : 11779 -----
931 14 8.7412E-02 (-103 -151):(102 -103 -156) imp:n=1 u=904 $ Bottom End Fitting
932 11 8.6735E-02 103 -104 -152 imp:n=1 u=904 $ Bottom Graphite Reflector
933 12 6.4196E-02 104 -105 -153 imp:n=1 u=904 $ Moly Poison Disc
934 13 4.3026E-02 105 -106 -154 imp:n=1 u=904 $ Zirconium Rod
973 2 5.0820E-05 105 -106 154 -159 imp:n=1 u=904 $ Zr/Fuel Gap
935 128 8.9458E-02 105 -106 159 -155 imp:n=1 u=904 $ Fuel Rod
936 11 8.6735E-02 106 -107 -152 imp:n=1 u=904 $ Top Graphite Reflector
937 2 5.0820E-05 (-103:104:152) (-104:105:153) (-105:106:155)
      (-106:107:152) (103 -108 -156) imp:n=1 u=904 $ Air Gap
938 14 8.7412E-02 102 -109 156 -157 imp:n=1 u=904 $ Cladding
939 14 8.7412E-02 (108 -158):(108 -109 -156) imp:n=1 u=904 $ Top End Fitting
940 1 9.9961E-02 157:(-102 151):(109 158) imp:n=1 u=904 $ Water
c
c ----- Fuel Assembly -----
941 1 9.9961E-02 -5 imp:n=1 u=900 $ Water Below Grid Plate
943 62 7.4744E-02 5 -7 imp:n=1 u=900 $ Grid Plate With Adapter
944 33 7.7699E-02 7 -9 imp:n=1 u=900 $ Lower Adapter
945 1 9.9961E-02 -132 131 -134 133 imp:n=1 u=905 lat=1 fill=-1:2 -1:2 0:0 $ Fuel Assemblies
      905 905 905 905
      905 903 904 905
      905 901 902 905

```

Fundamental - FUND

NRAD-FUND-RESR-001
CRIT-REAC-COEF

```

          905 905 905 905
946  0 9 -10 imp:n=1 u=900 fill=905 (-1.9431 -1.9431 0) $ Fuel Bundle
947 31 9.3070E-02 10 -12 imp:n=1 u=900 $ Upper Assembly
948  1 9.9961E-02 12 imp:n=1 u=900 $ Water Above Core
c
c ----- Position B-4 : 4-Rod Fuel Cluster -----
c ----- NW Fuel Rod : 11785 -----
1001 14 8.7412E-02 (-103 -151):(102 -103 -156) imp:n=1 u=1001 $ Bottom End Fitting
1002 11 8.6735E-02 103 -104 -152 imp:n=1 u=1001 $ Bottom Graphite Reflector
1003 12 6.4196E-02 104 -105 -153 imp:n=1 u=1001 $ Moly Poison Disc
1004 13 4.3026E-02 105 -106 -154 imp:n=1 u=1001 $ Zirconium Rod
1070  2 5.0820E-05 105 -106 154 -159 imp:n=1 u=1001 $ Zr/Fuel Gap
1005 134 8.9160E-02 105 -106 159 -155 imp:n=1 u=1001 $ Fuel Rod
1006 11 8.6735E-02 106 -107 -152 imp:n=1 u=1001 $ Top Graphite Reflector
1007  2 5.0820E-05 (-103:104:152) (-104:105:153) (-105:106:155)
(-106:107:152) (103 -108 -156) imp:n=1 u=1001 $ Air Gap
1008 14 8.7412E-02 102 -109 156 -157 imp:n=1 u=1001 $ Cladding
1009 14 8.7412E-02 (108 -158):(108 -109 -156) imp:n=1 u=1001 $ Top End Fitting
1010  1 9.9961E-02 157:(-102 151):(109 158) imp:n=1 u=1001 $ Water
c
c ----- NE Fuel Rod : 11787 -----
1011 14 8.7412E-02 (-103 -151):(102 -103 -156) imp:n=1 u=1002 $ Bottom End Fitting
1012 11 8.6735E-02 103 -104 -152 imp:n=1 u=1002 $ Bottom Graphite Reflector
1013 12 6.4196E-02 104 -105 -153 imp:n=1 u=1002 $ Moly Poison Disc
1014 13 4.3026E-02 105 -106 -154 imp:n=1 u=1002 $ Zirconium Rod
1071  2 5.0820E-05 105 -106 154 -159 imp:n=1 u=1002 $ Zr/Fuel Gap
1015 136 8.8980E-02 105 -106 159 -155 imp:n=1 u=1002 $ Fuel Rod
1016 11 8.6735E-02 106 -107 -152 imp:n=1 u=1002 $ Top Graphite Reflector
1017  2 5.0820E-05 (-103:104:152) (-104:105:153) (-105:106:155)
(-106:107:152) (103 -108 -156) imp:n=1 u=1002 $ Air Gap
1018 14 8.7412E-02 102 -109 156 -157 imp:n=1 u=1002 $ Cladding
1019 14 8.7412E-02 (108 -158):(108 -109 -156) imp:n=1 u=1002 $ Top End Fitting
1020  1 9.9961E-02 157:(-102 151):(109 158) imp:n=1 u=1002 $ Water
c
c ----- SW Fuel Rod : 11784 -----
1021 14 8.7412E-02 (-103 -151):(102 -103 -156) imp:n=1 u=1003 $ Bottom End Fitting
1022 11 8.6735E-02 103 -104 -152 imp:n=1 u=1003 $ Bottom Graphite Reflector
1023 12 6.4196E-02 104 -105 -153 imp:n=1 u=1003 $ Moly Poison Disc
1024 13 4.3026E-02 105 -106 -154 imp:n=1 u=1003 $ Zirconium Rod
1072  2 5.0820E-05 105 -106 154 -159 imp:n=1 u=1003 $ Zr/Fuel Gap
1025 133 8.9174E-02 105 -106 159 -155 imp:n=1 u=1003 $ Fuel Rod
1026 11 8.6735E-02 106 -107 -152 imp:n=1 u=1003 $ Top Graphite Reflector
1027  2 5.0820E-05 (-103:104:152) (-104:105:153) (-105:106:155)
(-106:107:152) (103 -108 -156) imp:n=1 u=1003 $ Air Gap
1028 14 8.7412E-02 102 -109 156 -157 imp:n=1 u=1003 $ Cladding
1029 14 8.7412E-02 (108 -158):(108 -109 -156) imp:n=1 u=1003 $ Top End Fitting
1030  1 9.9961E-02 157:(-102 151):(109 158) imp:n=1 u=1003 $ Water
c
c ----- SE Fuel Rod : 11786 -----
1031 14 8.7412E-02 (-103 -151):(102 -103 -156) imp:n=1 u=1004 $ Bottom End Fitting
1032 11 8.6735E-02 103 -104 -152 imp:n=1 u=1004 $ Bottom Graphite Reflector
1033 12 6.4196E-02 104 -105 -153 imp:n=1 u=1004 $ Moly Poison Disc
1034 13 4.3026E-02 105 -106 -154 imp:n=1 u=1004 $ Zirconium Rod
1073  2 5.0820E-05 105 -106 154 -159 imp:n=1 u=1004 $ Zr/Fuel Gap
1035 135 8.9542E-02 105 -106 159 -155 imp:n=1 u=1004 $ Fuel Rod
1036 11 8.6735E-02 106 -107 -152 imp:n=1 u=1004 $ Top Graphite Reflector
1037  2 5.0820E-05 (-103:104:152) (-104:105:153) (-105:106:155)
(-106:107:152) (103 -108 -156) imp:n=1 u=1004 $ Air Gap
1038 14 8.7412E-02 102 -109 156 -157 imp:n=1 u=1004 $ Cladding
1039 14 8.7412E-02 (108 -158):(108 -109 -156) imp:n=1 u=1004 $ Top End Fitting
1040  1 9.9961E-02 157:(-102 151):(109 158) imp:n=1 u=1004 $ Water
c
c ----- Fuel Assembly -----
1041  1 9.9961E-02 -5 imp:n=1 u=1000 $ Water Below Grid Plate
1043 62 7.4744E-02 5 -7 imp:n=1 u=1000 $ Grid Plate With Adapter
1044 33 7.7699E-02 7 -9 imp:n=1 u=1000 $ Lower Adapter
1045  1 9.9961E-02 -132 131 -134 133 imp:n=1 u=1005 lat=1 fill=-1:2 -1:2 0:0 $ Fuel Assemblies
1005 1005 1005 1005
1005 1003 1004 1005
1005 1001 1002 1005
1005 1005 1005 1005
1046  0 9 -10 imp:n=1 u=1000 fill=1005 (-1.9431 -1.9431 0) $ Fuel Bundle
1047 31 9.3070E-02 10 -12 imp:n=1 u=1000 $ Upper Assembly
1048  1 9.9961E-02 12 imp:n=1 u=1000 $ Water Above Core
c
c ----- Position B-5 : Graphite Reflector -----

```

Fundamental - FUND

NRAD-FUND-RESR-001
CRIT-REAC-COEF

```

1101 1 9.9961E-02 -5 imp:n=1 u=1100 $ Water Below Grid Plate
1103 63 6.9890E-02 5 -7 imp:n=1 u=1100 $ Grid Plate With Adapter
1104 44 7.6788E-02 7 -9 imp:n=1 u=1100 $ Lower Adapter
1105 41 7.8699E-02 (9 -10) (-9:303:354) (-9:303:355) (-9:305:351) (-306:10:356)
      (-306:10:357) (331 -332 333 -334) (-335 -336 -337 -338)
      imp:n=1 u=1100 $ Graphite Block
1106 42 6.0307E-02 307 -10 -356 imp:n=1 u=1100 $ Top Screw NE
1107 42 6.0307E-02 307 -10 -357 imp:n=1 u=1100 $ Top Screw SW
1108 1 9.9961E-02 306 -307 -356 imp:n=1 u=1100 $ Water in NE Top Hole
1109 1 9.9961E-02 306 -307 -357 imp:n=1 u=1100 $ Water in SW Top Hole
1110 42 6.0307E-02 9 -302 -352 imp:n=1 u=1100 $ Bottom Dowel NE
1111 42 6.0307E-02 9 -302 -353 imp:n=1 u=1100 $ Bottom Dowel SW
1112 42 6.0307E-02 9 -304 -351 imp:n=1 u=1100 $ Tie Rod
1113 1 9.9961E-02 (9 -303 352 -354):(302 -303 -354) imp:n=1 u=1100 $ Water in NE Bottom Hole
1114 1 9.9961E-02 (9 -303 353 -355):(302 -303 -355) imp:n=1 u=1100 $ Water in SW Bottom Hole
1115 1 9.9961E-02 (304 -305 -351) imp:n=1 u=1100 $ Water in Tie Rod Hole
1116 43 9.1820E-02 10 -309 imp:n=1 u=1100 $ Upper Assembly
1117 1 9.9961E-02 309 imp:n=1 u=1100 $ Water Above Core
1118 1 9.9961E-02 (9 -10) (-331:332:-333:334:335:336:337:338) imp:n=1 u=1100 $ Water Around
Assembly
c
c ----- Position B-6 : Graphite Reflector -----
1201 1 9.9961E-02 -5 imp:n=1 u=1200 $ Water Below Grid Plate
1203 63 6.9890E-02 5 -7 imp:n=1 u=1200 $ Grid Plate With Adapter
1204 44 7.6788E-02 7 -9 imp:n=1 u=1200 $ Lower Adapter
1205 41 7.8699E-02 (9 -10) (-9:303:354) (-9:303:355) (-9:305:351) (-306:10:356)
      (-306:10:357) (331 -332 333 -334) (-335 -336 -337 -338)
      imp:n=1 u=1200 $ Graphite Block
1206 42 6.0307E-02 307 -10 -356 imp:n=1 u=1200 $ Top Screw NE
1207 42 6.0307E-02 307 -10 -357 imp:n=1 u=1200 $ Top Screw SW
1208 1 9.9961E-02 306 -307 -356 imp:n=1 u=1200 $ Water in NE Top Hole
1209 1 9.9961E-02 306 -307 -357 imp:n=1 u=1200 $ Water in SW Top Hole
1210 42 6.0307E-02 9 -302 -352 imp:n=1 u=1200 $ Bottom Dowel NE
1211 42 6.0307E-02 9 -302 -353 imp:n=1 u=1200 $ Bottom Dowel SW
1212 42 6.0307E-02 9 -304 -351 imp:n=1 u=1200 $ Tie Rod
1213 1 9.9961E-02 (9 -303 352 -354):(302 -303 -354) imp:n=1 u=1200 $ Water in NE Bottom Hole
1214 1 9.9961E-02 (9 -303 353 -355):(302 -303 -355) imp:n=1 u=1200 $ Water in SW Bottom Hole
1215 1 9.9961E-02 (304 -305 -351) imp:n=1 u=1200 $ Water in Tie Rod Hole
1216 43 9.1820E-02 10 -309 imp:n=1 u=1200 $ Upper Assembly
1217 1 9.9961E-02 309 imp:n=1 u=1200 $ Water Above Core
1218 1 9.9961E-02 (9 -10) (-331:332:-333:334:335:336:337:338) imp:n=1 u=1200 $ Water Around
Assembly
c
c ----- Position C-1 : Graphite Reflector -----
1301 1 9.9961E-02 -5 imp:n=1 u=1300 $ Water Below Grid Plate
1303 63 6.9890E-02 5 -7 imp:n=1 u=1300 $ Grid Plate With Adapter
1304 44 7.6788E-02 7 -9 imp:n=1 u=1300 $ Lower Adapter
1305 41 7.8699E-02 (9 -10) (-9:303:354) (-9:303:355) (-9:305:351) (-306:10:356)
      (-306:10:357) (331 -332 333 -334) (-335 -336 -337 -338)
      imp:n=1 u=1300 $ Graphite Block
1306 42 6.0307E-02 307 -10 -356 imp:n=1 u=1300 $ Top Screw NE
1307 42 6.0307E-02 307 -10 -357 imp:n=1 u=1300 $ Top Screw SW
1308 1 9.9961E-02 306 -307 -356 imp:n=1 u=1300 $ Water in NE Top Hole
1309 1 9.9961E-02 306 -307 -357 imp:n=1 u=1300 $ Water in SW Top Hole
1310 42 6.0307E-02 9 -302 -352 imp:n=1 u=1300 $ Bottom Dowel NE
1311 42 6.0307E-02 9 -302 -353 imp:n=1 u=1300 $ Bottom Dowel SW
1312 42 6.0307E-02 9 -304 -351 imp:n=1 u=1300 $ Tie Rod
1313 1 9.9961E-02 (9 -303 352 -354):(302 -303 -354) imp:n=1 u=1300 $ Water in NE Bottom Hole
1314 1 9.9961E-02 (9 -303 353 -355):(302 -303 -355) imp:n=1 u=1300 $ Water in SW Bottom Hole
1315 1 9.9961E-02 (304 -305 -351) imp:n=1 u=1300 $ Water in Tie Rod Hole
1316 43 9.1820E-02 10 -309 imp:n=1 u=1300 $ Upper Assembly
1317 1 9.9961E-02 309 imp:n=1 u=1300 $ Water Above Core
1318 1 9.9961E-02 (9 -10) (-331:332:-333:334:335:336:337:338) imp:n=1 u=1300 $ Water Around
Assembly
c
c ----- Position C-2 : Shim Rod 2 Control Cluster -----
c ----- NW Fuel Rod : 11752 -----
1401 14 8.7412E-02 (-103 -151):(102 -103 -156) imp:n=1 u=1401 $ Bottom End Fitting
1402 11 8.6735E-02 103 -104 -152 imp:n=1 u=1401 $ Bottom Graphite Reflector
1403 12 6.4196E-02 104 -105 -153 imp:n=1 u=1401 $ Moly Poison Disc
1404 13 4.3026E-02 105 -106 -154 imp:n=1 u=1401 $ Zirconium Rod
1470 2 5.0820E-05 105 -106 154 -159 imp:n=1 u=1401 $ Zr/Fuel Gap
1405 101 8.9406E-02 105 -106 159 -155 imp:n=1 u=1401 $ Fuel Rod
1406 11 8.6735E-02 106 -107 -152 imp:n=1 u=1401 $ Top Graphite Reflector
1407 2 5.0820E-05 (-103:104:152) (-104:105:153) (-105:106:155)
      (-106:107:152) (103 -108 -156) imp:n=1 u=1401 $ Air Gap

```

Fundamental - FUND

NRAD-FUND-RESR-001
CRIT-REAC-COEF

```

1408 14 8.7412E-02 102 -109 156 -157 imp:n=1 u=1401 $ Cladding
1409 14 8.7412E-02 (108 -158):(108 -109 -156) imp:n=1 u=1401 $ Top End Fitting
1410 1 9.9961E-02 157:(-102 151):(109 158) imp:n=1 u=1401 $ Water
c
c ----- NE Control Rod : Shim 2 -----
1411 14 8.7412E-02 -201 -251 imp:n=1 u=1402 $ Bottom End Fitting
1412 23 6.7723E-02 201 -202 -253 imp:n=1 u=1402 $ Guide Tube Bottom
1413 25 6.1351E-02 202 -203 252 -253 imp:n=1 u=1402 $ Guide Tube
1414 1 9.9961E-02 (-201 251):253:(203 252) imp:n=1 u=1402 $ Water Outside Guide Tube
c
1450 22 5.9939E-02 231 -232 -275 imp:n=1 u=1406 $ Bottom End Fitting
1451 21 1.3514E-01 232 -233 -271 imp:n=1 u=1406 $ Absorber
1452 22 5.9939E-02 233 -234 272 -271 imp:n=1 u=1406 $ Spacer Disc
1453 22 5.9939E-02 234 -235 273 -274 imp:n=1 u=1406 $ Spacer Tube
1454 0 (232 -234 271 -275):(233 -234 -272):(234 -235 -273):(234 -235 274 -275)
    imp:n=1 u=1406 $ Void Space
1455 22 5.9939E-02 (235 -236 -275):(236 -237 -277) imp:n=1 u=1406 $ Top End Fitting
1456 22 5.9939E-02 231 -236 275 -276 imp:n=1 u=1406 $ Cladding
1457 24 6.8709E-02 237 -238 -278 imp:n=1 u=1406 $ Attachment Interface
1458 2 5.0820E-05 238 -239 -279 imp:n=1 u=1406 $ Inside Extension Rod
1459 22 5.9939E-02 238 -239 279 -280 imp:n=1 u=1406 $ Extension Rod
1460 1 9.9961E-02 (-231 -276):(276):(236 278):(238 280):(236 -237 277):(239)
    imp:n=1 u=1406 $ Water around Control Rod
c
c ----- SW Fuel Rod : 11753 -----
1421 14 8.7412E-02 (-103 -151):(102 -103 -156) imp:n=1 u=1403 $ Bottom End Fitting
1422 11 8.6735E-02 103 -104 -152 imp:n=1 u=1403 $ Bottom Graphite Reflector
1423 12 6.4196E-02 104 -105 -153 imp:n=1 u=1403 $ Moly Poison Disc
1424 13 4.3026E-02 105 -106 -154 imp:n=1 u=1403 $ Zirconium Rod
1472 2 5.0820E-05 105 -106 154 -159 imp:n=1 u=1403 $ Zr/Fuel Gap
1425 102 8.9321E-02 105 -106 159 -155 imp:n=1 u=1403 $ Fuel Rod
1426 11 8.6735E-02 106 -107 -152 imp:n=1 u=1403 $ Top Graphite Reflector
1427 2 5.0820E-05 (-103:104:152) (-104:105:153) (-105:106:155)
    (-106:107:152) (103 -108 -156) imp:n=1 u=1403 $ Air Gap
1428 14 8.7412E-02 102 -109 156 -157 imp:n=1 u=1403 $ Cladding
1429 14 8.7412E-02 (108 -158):(108 -109 -156) imp:n=1 u=1403 $ Top End Fitting
1430 1 9.9961E-02 157:(-102 151):(109 158) imp:n=1 u=1403 $ Water
c
c ----- SE Fuel Rod : 11754 -----
1431 14 8.7412E-02 (-103 -151):(102 -103 -156) imp:n=1 u=1404 $ Bottom End Fitting
1432 11 8.6735E-02 103 -104 -152 imp:n=1 u=1404 $ Bottom Graphite Reflector
1433 12 6.4196E-02 104 -105 -153 imp:n=1 u=1404 $ Moly Poison Disc
1434 13 4.3026E-02 105 -106 -154 imp:n=1 u=1404 $ Zirconium Rod
1473 2 5.0820E-05 105 -106 154 -159 imp:n=1 u=1404 $ Zr/Fuel Gap
1435 103 8.9350E-02 105 -106 159 -155 imp:n=1 u=1404 $ Fuel Rod
1436 11 8.6735E-02 106 -107 -152 imp:n=1 u=1404 $ Top Graphite Reflector
1437 2 5.0820E-05 (-103:104:152) (-104:105:153) (-105:106:155)
    (-106:107:152) (103 -108 -156) imp:n=1 u=1404 $ Air Gap
1438 14 8.7412E-02 102 -109 156 -157 imp:n=1 u=1404 $ Cladding
1439 14 8.7412E-02 (108 -158):(108 -109 -156) imp:n=1 u=1404 $ Top End Fitting
1440 1 9.9961E-02 157:(-102 151):(109 158) imp:n=1 u=1404 $ Water
c
c ----- Fuel Assembly -----
1441 1 9.9961E-02 -5 imp:n=1 u=1400 $ Water Below Grid Plate
1443 62 7.4744E-02 5 -7 imp:n=1 u=1400 $ Grid Plate With Adapter
1444 33 7.7699E-02 7 -9 imp:n=1 u=1400 $ Lower Adapter
1445 1 9.9961E-02 -132 131 -134 133 imp:n=1 u=1405 lat=1 fill=-1:2 -1:2 0:0 $ Fuel Assemblies
    1405 1405 1405 1405
    1405 1403 1404 1405
    1405 1401 1402 1405
    1405 1405 1405 1405
1446 0 9 -10 imp:n=1 u=1400 fill=1405 (-1.9431 -1.9431 0) $ Fuel Bundle
1447 32 9.1839E-02 10 -12 262 imp:n=1 u=1400 $ Upper Assembly
1448 1 9.9961E-02 12 262 imp:n=1 u=1400 $ Water Above Core
1449 0 10 -262 imp:n=1 u=1400 fill=1405 (-1.9431 -1.9431 0)
c
c ----- Position C-3 : 4-Rod Fuel Cluster -----
c ----- NW Fuel Rod : 11781 -----
1501 14 8.7412E-02 (-103 -151):(102 -103 -156) imp:n=1 u=1501 $ Bottom End Fitting
1502 11 8.6735E-02 103 -104 -152 imp:n=1 u=1501 $ Bottom Graphite Reflector
1503 12 6.4196E-02 104 -105 -153 imp:n=1 u=1501 $ Moly Poison Disc
1504 13 4.3026E-02 105 -106 -154 imp:n=1 u=1501 $ Zirconium Rod
1570 2 5.0820E-05 105 -106 154 -159 imp:n=1 u=1501 $ Zr/Fuel Gap
1505 130 8.9332E-02 105 -106 159 -155 imp:n=1 u=1501 $ Fuel Rod
1506 11 8.6735E-02 106 -107 -152 imp:n=1 u=1501 $ Top Graphite Reflector
1507 2 5.0820E-05 (-103:104:152) (-104:105:153) (-105:106:155)

```

Fundamental - FUND

NRAD-FUND-RESR-001
CRIT-REAC-COEF

```

(-106:107:152) (103 -108 -156) imp:n=1 u=1501 $ Air Gap
1508 14 8.7412E-02 102 -109 156 -157 imp:n=1 u=1501 $ Cladding
1509 14 8.7412E-02 (108 -158):(108 -109 -156) imp:n=1 u=1501 $ Top End Fitting
1510 1 9.9961E-02 157:(-102 151):(109 158) imp:n=1 u=1501 $ Water
c
c ----- NE Fuel Rod : 11782 -----
1511 14 8.7412E-02 (-103 -151):(102 -103 -156) imp:n=1 u=1502 $ Bottom End Fitting
1512 11 8.6735E-02 103 -104 -152 imp:n=1 u=1502 $ Bottom Graphite Reflector
1513 12 6.4196E-02 104 -105 -153 imp:n=1 u=1502 $ Moly Poison Disc
1514 13 4.3026E-02 105 -106 -154 imp:n=1 u=1502 $ Zirconium Rod
1571 2 5.0820E-05 105 -106 154 -159 imp:n=1 u=1502 $ Zr/Fuel Gap
1515 131 8.9074E-02 105 -106 159 -155 imp:n=1 u=1502 $ Fuel Rod
1516 11 8.6735E-02 106 -107 -152 imp:n=1 u=1502 $ Top Graphite Reflector
1517 2 5.0820E-05 (-103:104:152) (-104:105:153) (-105:106:155)
(-106:107:152) (103 -108 -156) imp:n=1 u=1502 $ Air Gap
1518 14 8.7412E-02 102 -109 156 -157 imp:n=1 u=1502 $ Cladding
1519 14 8.7412E-02 (108 -158):(108 -109 -156) imp:n=1 u=1502 $ Top End Fitting
1520 1 9.9961E-02 157:(-102 151):(109 158) imp:n=1 u=1502 $ Water
c
c ----- SW Fuel Rod : 11780 -----
1521 14 8.7412E-02 (-103 -151):(102 -103 -156) imp:n=1 u=1503 $ Bottom End Fitting
1522 11 8.6735E-02 103 -104 -152 imp:n=1 u=1503 $ Bottom Graphite Reflector
1523 12 6.4196E-02 104 -105 -153 imp:n=1 u=1503 $ Moly Poison Disc
1524 13 4.3026E-02 105 -106 -154 imp:n=1 u=1503 $ Zirconium Rod
1572 2 5.0820E-05 105 -106 154 -159 imp:n=1 u=1503 $ Zr/Fuel Gap
1525 129 8.9148E-02 105 -106 159 -155 imp:n=1 u=1503 $ Fuel Rod
1526 11 8.6735E-02 106 -107 -152 imp:n=1 u=1503 $ Top Graphite Reflector
1527 2 5.0820E-05 (-103:104:152) (-104:105:153) (-105:106:155)
(-106:107:152) (103 -108 -156) imp:n=1 u=1503 $ Air Gap
1528 14 8.7412E-02 102 -109 156 -157 imp:n=1 u=1503 $ Cladding
1529 14 8.7412E-02 (108 -158):(108 -109 -156) imp:n=1 u=1503 $ Top End Fitting
1530 1 9.9961E-02 157:(-102 151):(109 158) imp:n=1 u=1503 $ Water
c
c ----- SE Fuel Rod : 11783 -----
1531 14 8.7412E-02 (-103 -151):(102 -103 -156) imp:n=1 u=1504 $ Bottom End Fitting
1532 11 8.6735E-02 103 -104 -152 imp:n=1 u=1504 $ Bottom Graphite Reflector
1533 12 6.4196E-02 104 -105 -153 imp:n=1 u=1504 $ Moly Poison Disc
1534 13 4.3026E-02 105 -106 -154 imp:n=1 u=1504 $ Zirconium Rod
1573 2 5.0820E-05 105 -106 154 -159 imp:n=1 u=1504 $ Zr/Fuel Gap
1535 132 8.9084E-02 105 -106 159 -155 imp:n=1 u=1504 $ Fuel Rod
1536 11 8.6735E-02 106 -107 -152 imp:n=1 u=1504 $ Top Graphite Reflector
1537 2 5.0820E-05 (-103:104:152) (-104:105:153) (-105:106:155)
(-106:107:152) (103 -108 -156) imp:n=1 u=1504 $ Air Gap
1538 14 8.7412E-02 102 -109 156 -157 imp:n=1 u=1504 $ Cladding
1539 14 8.7412E-02 (108 -158):(108 -109 -156) imp:n=1 u=1504 $ Top End Fitting
1540 1 9.9961E-02 157:(-102 151):(109 158) imp:n=1 u=1504 $ Water
c
c ----- Fuel Assembly -----
1541 1 9.9961E-02 -5 imp:n=1 u=1500 $ Water Below Grid Plate
1543 62 7.4744E-02 5 -7 imp:n=1 u=1500 $ Grid Plate With Adapter
1544 33 7.7699E-02 7 -9 imp:n=1 u=1500 $ Lower Adapter
1545 1 9.9961E-02 -132 131 -134 133 imp:n=1 u=1505 lat=1 fill=-1:2 -1:2 0:0 $ Fuel Assemblies
1505 1505 1505 1505
1505 1503 1504 1505
1505 1501 1502 1505
1505 1505 1505 1505
1546 0 9 -10 imp:n=1 u=1500 fill=1505 (-1.9431 -1.9431 0) $ Fuel Bundle
1547 31 9.3070E-02 10 -12 imp:n=1 u=1500 $ Upper Assembly
1548 1 9.9961E-02 12 imp:n=1 u=1500 $ Water Above Core
c
c ----- Position C-4 : Sample Irradiation Cluster -----
c ----- NW Fuel Rod : 11761 -----
1601 14 8.7412E-02 (-103 -151):(102 -103 -156) imp:n=1 u=1601 $ Bottom End Fitting
1602 11 8.6735E-02 103 -104 -152 imp:n=1 u=1601 $ Bottom Graphite Reflector
1603 12 6.4196E-02 104 -105 -153 imp:n=1 u=1601 $ Moly Poison Disc
1604 13 4.3026E-02 105 -106 -154 imp:n=1 u=1601 $ Zirconium Rod
1670 2 5.0820E-05 105 -106 154 -159 imp:n=1 u=1601 $ Zr/Fuel Gap
1605 110 8.9148E-02 105 -106 159 -155 imp:n=1 u=1601 $ Fuel Rod
1606 11 8.6735E-02 106 -107 -152 imp:n=1 u=1601 $ Top Graphite Reflector
1607 2 5.0820E-05 (-103:104:152) (-104:105:153) (-105:106:155)
(-106:107:152) (103 -108 -156) imp:n=1 u=1601 $ Air Gap
1608 14 8.7412E-02 102 -109 156 -157 imp:n=1 u=1601 $ Cladding
1609 14 8.7412E-02 (108 -158):(108 -109 -156) imp:n=1 u=1601 $ Top End Fitting
1610 1 9.9961E-02 157:(-102 151):(109 158) imp:n=1 u=1601 $ Water
c
c ----- NE Fuel Rod : 11762 -----

```

Fundamental - FUND

NRAD-FUND-RESR-001
CRIT-REAC-COEF

```

1611 14 8.7412E-02 (-103 -151):(102 -103 -156) imp:n=1 u=1602 $ Bottom End Fitting
1612 11 8.6735E-02 103 -104 -152 imp:n=1 u=1602 $ Bottom Graphite Reflector
1613 12 6.4196E-02 104 -105 -153 imp:n=1 u=1602 $ Moly Poison Disc
1614 13 4.3026E-02 105 -106 -154 imp:n=1 u=1602 $ Zirconium Rod
1671 2 5.0820E-05 105 -106 154 -159 imp:n=1 u=1602 $ Zr/Fuel Gap
1615 111 8.9229E-02 105 -106 159 -155 imp:n=1 u=1602 $ Fuel Rod
1616 11 8.6735E-02 106 -107 -152 imp:n=1 u=1602 $ Top Graphite Reflector
1617 2 5.0820E-05 (-103:104:152) (-104:105:153) (-105:106:155)
(-106:107:152) (103 -108 -156) imp:n=1 u=1602 $ Air Gap
1618 14 8.7412E-02 102 -109 156 -157 imp:n=1 u=1602 $ Cladding
1619 14 8.7412E-02 (108 -158):(108 -109 -156) imp:n=1 u=1602 $ Top End Fitting
1620 1 9.9961E-02 157:(-102 151):(109 158) imp:n=1 u=1602 $ Water
c
c ----- SW Water Hole (Irradiation Position) ----- ---
1621 14 8.7412E-02 -201 -251 imp:n=1 u=1603 $ Bottom End Fitting
1622 23 6.7723E-02 201 -202 -253 imp:n=1 u=1603 $ Guide Tube Bottom
1623 25 6.1351E-02 202 -203 252 -253 imp:n=1 u=1603 $ Guide Tube
1624 1 9.9961E-02 (-201 251):253:(203 252) imp:n=1 u=1603 $ Water Outside Guide Tube
1625 1 9.9961E-02 202 -252 imp:n=1 u=1603 $ Water Hole
c
c ----- SE Fuel Rod : 11763 ----- ---
1631 14 8.7412E-02 (-103 -151):(102 -103 -156) imp:n=1 u=1604 $ Bottom End Fitting
1632 11 8.6735E-02 103 -104 -152 imp:n=1 u=1604 $ Bottom Graphite Reflector
1633 12 6.4196E-02 104 -105 -153 imp:n=1 u=1604 $ Moly Poison Disc
1634 13 4.3026E-02 105 -106 -154 imp:n=1 u=1604 $ Zirconium Rod
1673 2 5.0820E-05 105 -106 154 -159 imp:n=1 u=1604 $ Zr/Fuel Gap
1635 112 8.9575E-02 105 -106 159 -155 imp:n=1 u=1604 $ Fuel Rod
1636 11 8.6735E-02 106 -107 -152 imp:n=1 u=1604 $ Top Graphite Reflector
1637 2 5.0820E-05 (-103:104:152) (-104:105:153) (-105:106:155)
(-106:107:152) (103 -108 -156) imp:n=1 u=1604 $ Air Gap
1638 14 8.7412E-02 102 -109 156 -157 imp:n=1 u=1604 $ Cladding
1639 14 8.7412E-02 (108 -158):(108 -109 -156) imp:n=1 u=1604 $ Top End Fitting
1640 1 9.9961E-02 157:(-102 151):(109 158) imp:n=1 u=1604 $ Water
c
c ----- Fuel Assembly -----
1641 1 9.9961E-02 -5 imp:n=1 u=1600 $ Water Below Grid Plate
1643 62 7.4744E-02 5 -7 imp:n=1 u=1600 $ Grid Plate With Adapter
1644 33 7.7699E-02 7 -9 imp:n=1 u=1600 $ Lower Adapter
1645 1 9.9961E-02 -132 131 -134 133 imp:n=1 u=1605 lat=1 fill=-1:2 -1:2 0:0 $ Fuel Assemblies
1605 1605 1605 1605
1605 1603 1604 1605
1605 1601 1602 1605
1605 1605 1605 1605
1646 0 9 -10 imp:n=1 u=1600 fill=1605 (-1.9431 -1.9431 0) $ Fuel Bundle
1647 32 9.1839E-02 10 -12 263 imp:n=1 u=1600 $ Upper Assembly
1648 1 9.9961E-02 12 263 imp:n=1 u=1600 $ Water Above Core
1649 0 10 -263 imp:n=1 u=1600 fill=1605 (-1.9431 -1.9431 0)
c
c ----- Position C-5 : 4-Rod Fuel Cluster -----
c ----- NW Fuel Rod : 11795 ----- ---
1701 14 8.7412E-02 (-103 -151):(102 -103 -156) imp:n=1 u=1701 $ Bottom End Fitting
1702 11 8.6735E-02 103 -104 -152 imp:n=1 u=1701 $ Bottom Graphite Reflector
1703 12 6.4196E-02 104 -105 -153 imp:n=1 u=1701 $ Moly Poison Disc
1704 13 4.3026E-02 105 -106 -154 imp:n=1 u=1701 $ Zirconium Rod
1770 2 5.0820E-05 105 -106 154 -159 imp:n=1 u=1701 $ Zr/Fuel Gap
1705 144 8.9530E-02 105 -106 159 -155 imp:n=1 u=1701 $ Fuel Rod
1706 11 8.6735E-02 106 -107 -152 imp:n=1 u=1701 $ Top Graphite Reflector
1707 2 5.0820E-05 (-103:104:152) (-104:105:153) (-105:106:155)
(-106:107:152) (103 -108 -156) imp:n=1 u=1701 $ Air Gap
1708 14 8.7412E-02 102 -109 156 -157 imp:n=1 u=1701 $ Cladding
1709 14 8.7412E-02 (108 -158):(108 -109 -156) imp:n=1 u=1701 $ Top End Fitting
1710 1 9.9961E-02 157:(-102 151):(109 158) imp:n=1 u=1701 $ Water
c
c ----- NE Fuel Rod : 11792 ----- ---
1711 14 8.7412E-02 (-103 -151):(102 -103 -156) imp:n=1 u=1702 $ Bottom End Fitting
1712 11 8.6735E-02 103 -104 -152 imp:n=1 u=1702 $ Bottom Graphite Reflector
1713 12 6.4196E-02 104 -105 -153 imp:n=1 u=1702 $ Moly Poison Disc
1714 13 4.3026E-02 105 -106 -154 imp:n=1 u=1702 $ Zirconium Rod
1771 2 5.0820E-05 105 -106 154 -159 imp:n=1 u=1702 $ Zr/Fuel Gap
1715 141 8.8974E-02 105 -106 159 -155 imp:n=1 u=1702 $ Fuel Rod
1716 11 8.6735E-02 106 -107 -152 imp:n=1 u=1702 $ Top Graphite Reflector
1717 2 5.0820E-05 (-103:104:152) (-104:105:153) (-105:106:155)
(-106:107:152) (103 -108 -156) imp:n=1 u=1702 $ Air Gap
1718 14 8.7412E-02 102 -109 156 -157 imp:n=1 u=1702 $ Cladding
1719 14 8.7412E-02 (108 -158):(108 -109 -156) imp:n=1 u=1702 $ Top End Fitting
1720 1 9.9961E-02 157:(-102 151):(109 158) imp:n=1 u=1702 $ Water

```

Fundamental - FUND

NRAD-FUND-RESR-001
CRIT-REAC-COEF

```

c
c ----- SW Fuel Rod : 11794 -----
1721 14 8.7412E-02 (-103 -151):(102 -103 -156) imp:n=1 u=1703 $ Bottom End Fitting
1722 11 8.6735E-02 103 -104 -152 imp:n=1 u=1703 $ Bottom Graphite Reflector
1723 12 6.4196E-02 104 -105 -153 imp:n=1 u=1703 $ Moly Poison Disc
1724 13 4.3026E-02 105 -106 -154 imp:n=1 u=1703 $ Zirconium Rod
1772 2 5.0820E-05 105 -106 154 -159 imp:n=1 u=1703 $ Zr/Fuel Gap
1725 143 8.9194E-02 105 -106 159 -155 imp:n=1 u=1703 $ Fuel Rod
1726 11 8.6735E-02 106 -107 -152 imp:n=1 u=1703 $ Top Graphite Reflector
1727 2 5.0820E-05 (-103:104:152) (-104:105:153) (-105:106:155)
(-106:107:152) (103 -108 -156) imp:n=1 u=1703 $ Air Gap
1728 14 8.7412E-02 102 -109 156 -157 imp:n=1 u=1703 $ Cladding
1729 14 8.7412E-02 (108 -158):(108 -109 -156) imp:n=1 u=1703 $ Top End Fitting
1730 1 9.9961E-02 157:(-102 151):(109 158) imp:n=1 u=1703 $ Water
c
c ----- SE Fuel Rod : 11793 -----
1731 14 8.7412E-02 (-103 -151):(102 -103 -156) imp:n=1 u=1704 $ Bottom End Fitting
1732 11 8.6735E-02 103 -104 -152 imp:n=1 u=1704 $ Bottom Graphite Reflector
1733 12 6.4196E-02 104 -105 -153 imp:n=1 u=1704 $ Moly Poison Disc
1734 13 4.3026E-02 105 -106 -154 imp:n=1 u=1704 $ Zirconium Rod
1773 2 5.0820E-05 105 -106 154 -159 imp:n=1 u=1704 $ Zr/Fuel Gap
1735 142 8.9315E-02 105 -106 159 -155 imp:n=1 u=1704 $ Fuel Rod
1736 11 8.6735E-02 106 -107 -152 imp:n=1 u=1704 $ Top Graphite Reflector
1737 2 5.0820E-05 (-103:104:152) (-104:105:153) (-105:106:155)
(-106:107:152) (103 -108 -156) imp:n=1 u=1704 $ Air Gap
1738 14 8.7412E-02 102 -109 156 -157 imp:n=1 u=1704 $ Cladding
1739 14 8.7412E-02 (108 -158):(108 -109 -156) imp:n=1 u=1704 $ Top End Fitting
1740 1 9.9961E-02 157:(-102 151):(109 158) imp:n=1 u=1704 $ Water
c
c ----- Fuel Assembly -----
1741 1 9.9961E-02 -5 imp:n=1 u=1700 $ Water Below Grid Plate
1743 62 7.4744E-02 5 -7 imp:n=1 u=1700 $ Grid Plate With Adapter
1744 33 7.7699E-02 7 -9 imp:n=1 u=1700 $ Lower Adapter
1745 1 9.9961E-02 -132 131 -134 133 imp:n=1 u=1705 lat=1 fill=-1:2 -1:2 0:0 $ Fuel Assemblies
1705 1705 1705 1705
1705 1703 1704 1705
1705 1701 1702 1705
1705 1705 1705 1705
1746 0 9 -10 imp:n=1 u=1700 fill=1705 (-1.9431 -1.9431 0) $ Fuel Bundle
1747 31 9.3070E-02 10 -12 imp:n=1 u=1700 $ Upper Assembly
1748 1 9.9961E-02 12 imp:n=1 u=1700 $ Water Above Core
c
c ----- Position C-6 : East Beam Tube Support -----
1801 1 9.9961E-02 -5 imp:n=1 u=1800 $ Water Below Grid Plate
1803 64 7.5685E-02 5 -7 imp:n=1 u=1800 $ Grid Plate With Support
1804 51 9.1752E-02 7 -401 imp:n=1 u=1800 $ Beam Tube Support
1805 1 9.9961E-02 401 imp:n=1 u=1800 $ Water Above Support
c
c ----- Position D-1 : Graphite Reflector -----
1901 1 9.9961E-02 -5 imp:n=1 u=1900 $ Water Below Grid Plate
1903 63 6.9890E-02 5 -7 imp:n=1 u=1900 $ Grid Plate With Adapter
1904 44 7.6788E-02 7 -9 imp:n=1 u=1900 $ Lower Adapter
1905 41 7.8699E-02 (9 -10) (-9:303:354) (-9:303:355) (-9:305:351) (-306:10:356)
(-306:10:357) (331 -332 333 -334) (-335 -336 -337 -338)
imp:n=1 u=1900 $ Graphite Block
1906 42 6.0307E-02 307 -10 -356 imp:n=1 u=1900 $ Top Screw NE
1907 42 6.0307E-02 307 -10 -357 imp:n=1 u=1900 $ Top Screw SW
1908 1 9.9961E-02 306 -307 -356 imp:n=1 u=1900 $ Water in NE Top Hole
1909 1 9.9961E-02 306 -307 -357 imp:n=1 u=1900 $ Water in SW Top Hole
1910 42 6.0307E-02 9 -302 -352 imp:n=1 u=1900 $ Bottom Dowel NE
1911 42 6.0307E-02 9 -302 -353 imp:n=1 u=1900 $ Bottom Dowel SW
1912 42 6.0307E-02 9 -304 -351 imp:n=1 u=1900 $ Tie Rod
1913 1 9.9961E-02 (9 -303 352 -354):(302 -303 -354) imp:n=1 u=1900 $ Water in NE Bottom Hole
1914 1 9.9961E-02 (9 -303 353 -355):(302 -303 -355) imp:n=1 u=1900 $ Water in SW Bottom Hole
1915 1 9.9961E-02 (304 -305 -351) imp:n=1 u=1900 $ Water in Tie Rod Hole
1916 43 9.1820E-02 10 -309 imp:n=1 u=1900 $ Upper Assembly
1917 1 9.9961E-02 309 imp:n=1 u=1900 $ Water Above Core
1918 1 9.9961E-02 (9 -10) (-331:332:-333:334:335:336:337:338) imp:n=1 u=1900 $ Water Around
Assembly
c
c ----- Position D-2 : Shim Rod 1 Control Cluster -----
c ----- NW Fuel Rod : 11755 -----
2001 14 8.7412E-02 (-103 -151):(102 -103 -156) imp:n=1 u=2001 $ Bottom End Fitting
2002 11 8.6735E-02 103 -104 -152 imp:n=1 u=2001 $ Bottom Graphite Reflector
2003 12 6.4196E-02 104 -105 -153 imp:n=1 u=2001 $ Moly Poison Disc
2004 13 4.3026E-02 105 -106 -154 imp:n=1 u=2001 $ Zirconium Rod

```

Fundamental - FUND

NRAD-FUND-RESR-001
CRIT-REAC-COEF

```

2070 2 5.0820E-05 105 -106 154 -159 imp:n=1 u=2001 $ Zr/Fuel Gap
2005 104 8.9597E-02 105 -106 159 -155 imp:n=1 u=2001 $ Fuel Rod
2006 11 8.6735E-02 106 -107 -152 imp:n=1 u=2001 $ Top Graphite Reflector
2007 2 5.0820E-05 (-103:104:152) (-104:105:153) (-105:106:155)
(-106:107:152) (103 -108 -156) imp:n=1 u=2001 $ Air Gap
2008 14 8.7412E-02 102 -109 156 -157 imp:n=1 u=2001 $ Cladding
2009 14 8.7412E-02 (108 -158):(108 -109 -156) imp:n=1 u=2001 $ Top End Fitting
2010 1 9.9961E-02 157:(-102 151):(109 158) imp:n=1 u=2001 $ Water
c
c ----- NE Fuel Rod : 11757 -----
2011 14 8.7412E-02 (-103 -151):(102 -103 -156) imp:n=1 u=2002 $ Bottom End Fitting
2012 11 8.6735E-02 103 -104 -152 imp:n=1 u=2002 $ Bottom Graphite Reflector
2013 12 6.4196E-02 104 -105 -153 imp:n=1 u=2002 $ Moly Poison Disc
2014 13 4.3026E-02 105 -106 -154 imp:n=1 u=2002 $ Zirconium Rod
2071 2 5.0820E-05 105 -106 154 -159 imp:n=1 u=2002 $ Zr/Fuel Gap
2015 106 8.9289E-02 105 -106 159 -155 imp:n=1 u=2002 $ Fuel Rod
2016 11 8.6735E-02 106 -107 -152 imp:n=1 u=2002 $ Top Graphite Reflector
2017 2 5.0820E-05 (-103:104:152) (-104:105:153) (-105:106:155)
(-106:107:152) (103 -108 -156) imp:n=1 u=2002 $ Air Gap
2018 14 8.7412E-02 102 -109 156 -157 imp:n=1 u=2002 $ Cladding
2019 14 8.7412E-02 (108 -158):(108 -109 -156) imp:n=1 u=2002 $ Top End Fitting
2020 1 9.9961E-02 157:(-102 151):(109 158) imp:n=1 u=2002 $ Water
c
c ----- SW Fuel Rod : 11756 -----
2021 14 8.7412E-02 (-103 -151):(102 -103 -156) imp:n=1 u=2003 $ Bottom End Fitting
2022 11 8.6735E-02 103 -104 -152 imp:n=1 u=2003 $ Bottom Graphite Reflector
2023 12 6.4196E-02 104 -105 -153 imp:n=1 u=2003 $ Moly Poison Disc
2024 13 4.3026E-02 105 -106 -154 imp:n=1 u=2003 $ Zirconium Rod
2072 2 5.0820E-05 105 -106 154 -159 imp:n=1 u=2003 $ Zr/Fuel Gap
2025 105 8.9329E-02 105 -106 159 -155 imp:n=1 u=2003 $ Fuel Rod
2026 11 8.6735E-02 106 -107 -152 imp:n=1 u=2003 $ Top Graphite Reflector
2027 2 5.0820E-05 (-103:104:152) (-104:105:153) (-105:106:155)
(-106:107:152) (103 -108 -156) imp:n=1 u=2003 $ Air Gap
2028 14 8.7412E-02 102 -109 156 -157 imp:n=1 u=2003 $ Cladding
2029 14 8.7412E-02 (108 -158):(108 -109 -156) imp:n=1 u=2003 $ Top End Fitting
2030 1 9.9961E-02 157:(-102 151):(109 158) imp:n=1 u=2003 $ Water
c
c ----- SE Control Rod : Shim 1 -----
2031 14 8.7412E-02 -201 -251 imp:n=1 u=2004 $ Bottom End Fitting
2032 23 6.7723E-02 201 -202 -253 imp:n=1 u=2004 $ Guide Tube Bottom
2033 25 6.1351E-02 202 -203 252 -253 imp:n=1 u=2004 $ Guide Tube
2034 1 9.9961E-02 (-201 251):253:(203 252) imp:n=1 u=2004 $ Water Outside Guide Tube
c
2050 22 5.9939E-02 231 -232 -275 imp:n=1 u=2006 $ Bottom End Fitting
2051 21 1.3514E-01 232 -233 -271 imp:n=1 u=2006 $ Absorber
2052 22 5.9939E-02 233 -234 272 -271 imp:n=1 u=2006 $ Spacer Disc
2053 22 5.9939E-02 234 -235 273 -274 imp:n=1 u=2006 $ Spacer Tube
2054 0 (232 -234 271 -275):(233 -234 -272):(234 -235 -273):(234 -235 274 -275)
imp:n=1 u=2006 $ Void Space
2055 22 5.9939E-02 (235 -236 -275):(236 -237 -277) imp:n=1 u=2006 $ Top End Fitting
2056 22 5.9939E-02 231 -236 275 -276 imp:n=1 u=2006 $ Cladding
2057 24 6.8709E-02 237 -238 -278 imp:n=1 u=2006 $ Attachment Interface
2058 2 5.0820E-05 238 -239 -279 imp:n=1 u=2006 $ Inside Extension Rod
2059 22 5.9939E-02 238 -239 279 -280 imp:n=1 u=2006 $ Extension Rod
2060 1 9.9961E-02 (-231 -276):(276):(236 278):(238 280):(236 -237 277):(239)
imp:n=1 u=2006 $ Water around Control Rod
c
c ----- Fuel Assembly -----
2041 1 9.9961E-02 -5 imp:n=1 u=2000 $ Water Below Grid Plate
2043 62 7.4744E-02 5 -7 imp:n=1 u=2000 $ Grid Plate With Adapter
2044 33 7.7699E-02 7 -9 imp:n=1 u=2000 $ Lower Adapter
2045 1 9.9961E-02 -132 131 -134 133 imp:n=1 u=2005 lat=1 fill=-1:2 -1:2 0:0 $ Fuel Assemblies
2005 2005 2005 2005
2005 2003 2004 2005
2005 2001 2002 2005
2005 2005 2005 2005
2046 0 9 -10 imp:n=1 u=2000 fill=2005 (-1.9431 -1.9431 0) $ Fuel Bundle
2047 32 9.1839E-02 10 -12 264 imp:n=1 u=2000 $ Upper Assembly
2048 1 9.9961E-02 12 264 imp:n=1 u=2000 $ Water Above Core
2049 0 10 -264 imp:n=1 u=2000 fill=2005 (-1.9431 -1.9431 0)
c
c ----- Position D-3 : 4-Rod Fuel Cluster -----
c ----- NW Fuel Rod : 11772 -----
2101 14 8.7412E-02 (-103 -151):(102 -103 -156) imp:n=1 u=2101 $ Bottom End Fitting
2102 11 8.6735E-02 103 -104 -152 imp:n=1 u=2101 $ Bottom Graphite Reflector
2103 12 6.4196E-02 104 -105 -153 imp:n=1 u=2101 $ Moly Poison Disc

```

Fundamental - FUND

NRAD-FUND-RESR-001
CRIT-REAC-COEF

```

2104 13 4.3026E-02 105 -106 -154 imp:n=1 u=2101 $ Zirconium Rod
2170 2 5.0820E-05 105 -106 154 -159 imp:n=1 u=2101 $ Zr/Fuel Gap
2105 121 8.9089E-02 105 -106 159 -155 imp:n=1 u=2101 $ Fuel Rod
2106 11 8.6735E-02 106 -107 -152 imp:n=1 u=2101 $ Top Graphite Reflector
2107 2 5.0820E-05 (-103:104:152) (-104:105:153) (-105:106:155)
(-106:107:152) (103 -108 -156) imp:n=1 u=2101 $ Air Gap
2108 14 8.7412E-02 102 -109 156 -157 imp:n=1 u=2101 $ Cladding
2109 14 8.7412E-02 (108 -158):(108 -109 -156) imp:n=1 u=2101 $ Top End Fitting
2110 1 9.9961E-02 157:(-102 151):(109 158) imp:n=1 u=2101 $ Water
c
c ----- NE Fuel Rod : 11773 ----- ---
2111 14 8.7412E-02 (-103 -151):(102 -103 -156) imp:n=1 u=2102 $ Bottom End Fitting
2112 11 8.6735E-02 103 -104 -152 imp:n=1 u=2102 $ Bottom Graphite Reflector
2113 12 6.4196E-02 104 -105 -153 imp:n=1 u=2102 $ Moly Poison Disc
2114 13 4.3026E-02 105 -106 -154 imp:n=1 u=2102 $ Zirconium Rod
2171 2 5.0820E-05 105 -106 154 -159 imp:n=1 u=2102 $ Zr/Fuel Gap
2115 122 8.9311E-02 105 -106 159 -155 imp:n=1 u=2102 $ Fuel Rod
2116 11 8.6735E-02 106 -107 -152 imp:n=1 u=2102 $ Top Graphite Reflector
2117 2 5.0820E-05 (-103:104:152) (-104:105:153) (-105:106:155)
(-106:107:152) (103 -108 -156) imp:n=1 u=2102 $ Air Gap
2118 14 8.7412E-02 102 -109 156 -157 imp:n=1 u=2102 $ Cladding
2119 14 8.7412E-02 (108 -158):(108 -109 -156) imp:n=1 u=2102 $ Top End Fitting
2120 1 9.9961E-02 157:(-102 151):(109 158) imp:n=1 u=2102 $ Water
c
c ----- SW Fuel Rod : 11774 ----- ---
2121 14 8.7412E-02 (-103 -151):(102 -103 -156) imp:n=1 u=2103 $ Bottom End Fitting
2122 11 8.6735E-02 103 -104 -152 imp:n=1 u=2103 $ Bottom Graphite Reflector
2123 12 6.4196E-02 104 -105 -153 imp:n=1 u=2103 $ Moly Poison Disc
2124 13 4.3026E-02 105 -106 -154 imp:n=1 u=2103 $ Zirconium Rod
2172 2 5.0820E-05 105 -106 154 -159 imp:n=1 u=2103 $ Zr/Fuel Gap
2125 123 9.0290E-02 105 -106 159 -155 imp:n=1 u=2103 $ Fuel Rod
2126 11 8.6735E-02 106 -107 -152 imp:n=1 u=2103 $ Top Graphite Reflector
2127 2 5.0820E-05 (-103:104:152) (-104:105:153) (-105:106:155)
(-106:107:152) (103 -108 -156) imp:n=1 u=2103 $ Air Gap
2128 14 8.7412E-02 102 -109 156 -157 imp:n=1 u=2103 $ Cladding
2129 14 8.7412E-02 (108 -158):(108 -109 -156) imp:n=1 u=2103 $ Top End Fitting
2130 1 9.9961E-02 157:(-102 151):(109 158) imp:n=1 u=2103 $ Water
c
c ----- SE Fuel Rod : 11775 ----- ---
2131 14 8.7412E-02 (-103 -151):(102 -103 -156) imp:n=1 u=2104 $ Bottom End Fitting
2132 11 8.6735E-02 103 -104 -152 imp:n=1 u=2104 $ Bottom Graphite Reflector
2133 12 6.4196E-02 104 -105 -153 imp:n=1 u=2104 $ Moly Poison Disc
2134 13 4.3026E-02 105 -106 -154 imp:n=1 u=2104 $ Zirconium Rod
2173 2 5.0820E-05 105 -106 154 -159 imp:n=1 u=2104 $ Zr/Fuel Gap
2135 124 8.9272E-02 105 -106 159 -155 imp:n=1 u=2104 $ Fuel Rod
2136 11 8.6735E-02 106 -107 -152 imp:n=1 u=2104 $ Top Graphite Reflector
2137 2 5.0820E-05 (-103:104:152) (-104:105:153) (-105:106:155)
(-106:107:152) (103 -108 -156) imp:n=1 u=2104 $ Air Gap
2138 14 8.7412E-02 102 -109 156 -157 imp:n=1 u=2104 $ Cladding
2139 14 8.7412E-02 (108 -158):(108 -109 -156) imp:n=1 u=2104 $ Top End Fitting
2140 1 9.9961E-02 157:(-102 151):(109 158) imp:n=1 u=2104 $ Water
c
c ----- Fuel Assembly -----
2141 1 9.9961E-02 -5 imp:n=1 u=2100 $ Water Below Grid Plate
2143 62 7.4744E-02 5 -7 imp:n=1 u=2100 $ Grid Plate With Adapter
2144 33 7.7699E-02 7 -9 imp:n=1 u=2100 $ Lower Adapter
2145 1 9.9961E-02 -132 131 -134 133 imp:n=1 u=2105 lat=1 fill=-1:2 -1:2 0:0 $ Fuel Assemblies
2105 2105 2105 2105
2105 2103 2104 2105
2105 2101 2102 2105
2105 2105 2105 2105
2146 0 9 -10 imp:n=1 u=2100 fill=2105 (-1.9431 -1.9431 0) $ Fuel Bundle
2147 31 9.3070E-02 10 -12 imp:n=1 u=2100 $ Upper Assembly
2148 1 9.9961E-02 12 imp:n=1 u=2100 $ Water Above Core
c
c ----- Position D-4 : 4-Rod Fuel Cluster -----
c ----- NW Fuel Rod : 11768 ----- ---
2201 14 8.7412E-02 (-103 -151):(102 -103 -156) imp:n=1 u=2201 $ Bottom End Fitting
2202 11 8.6735E-02 103 -104 -152 imp:n=1 u=2201 $ Bottom Graphite Reflector
2203 12 6.4196E-02 104 -105 -153 imp:n=1 u=2201 $ Moly Poison Disc
2204 13 4.3026E-02 105 -106 -154 imp:n=1 u=2201 $ Zirconium Rod
2270 2 5.0820E-05 105 -106 154 -159 imp:n=1 u=2201 $ Zr/Fuel Gap
2205 117 8.9003E-02 105 -106 159 -155 imp:n=1 u=2201 $ Fuel Rod
2206 11 8.6735E-02 106 -107 -152 imp:n=1 u=2201 $ Top Graphite Reflector
2207 2 5.0820E-05 (-103:104:152) (-104:105:153) (-105:106:155)
(-106:107:152) (103 -108 -156) imp:n=1 u=2201 $ Air Gap

```

Fundamental - FUND

NRAD-FUND-RESR-001
CRIT-REAC-COEF

```

2208 14 8.7412E-02 102 -109 156 -157 imp:n=1 u=2201 $ Cladding
2209 14 8.7412E-02 (108 -158):(108 -109 -156) imp:n=1 u=2201 $ Top End Fitting
2210 1 9.9961E-02 157:(-102 151):(109 158) imp:n=1 u=2201 $ Water
c
c ----- NE Fuel Rod : 11769 -----
2211 14 8.7412E-02 (-103 -151):(102 -103 -156) imp:n=1 u=2202 $ Bottom End Fitting
2212 11 8.6735E-02 103 -104 -152 imp:n=1 u=2202 $ Bottom Graphite Reflector
2213 12 6.4196E-02 104 -105 -153 imp:n=1 u=2202 $ Moly Poison Disc
2214 13 4.3026E-02 105 -106 -154 imp:n=1 u=2202 $ Zirconium Rod
2271 2 5.0820E-05 105 -106 154 -159 imp:n=1 u=2202 $ Zr/Fuel Gap
2215 118 8.8885E-02 105 -106 159 -155 imp:n=1 u=2202 $ Fuel Rod
2216 11 8.6735E-02 106 -107 -152 imp:n=1 u=2202 $ Top Graphite Reflector
2217 2 5.0820E-05 (-103:104:152) (-104:105:153) (-105:106:155)
(-106:107:152) (103 -108 -156) imp:n=1 u=2202 $ Air Gap
2218 14 8.7412E-02 102 -109 156 -157 imp:n=1 u=2202 $ Cladding
2219 14 8.7412E-02 (108 -158):(108 -109 -156) imp:n=1 u=2202 $ Top End Fitting
2220 1 9.9961E-02 157:(-102 151):(109 158) imp:n=1 u=2202 $ Water
c
c ----- SW Fuel Rod : 11770 -----
2221 14 8.7412E-02 (-103 -151):(102 -103 -156) imp:n=1 u=2203 $ Bottom End Fitting
2222 11 8.6735E-02 103 -104 -152 imp:n=1 u=2203 $ Bottom Graphite Reflector
2223 12 6.4196E-02 104 -105 -153 imp:n=1 u=2203 $ Moly Poison Disc
2224 13 4.3026E-02 105 -106 -154 imp:n=1 u=2203 $ Zirconium Rod
2272 2 5.0820E-05 105 -106 154 -159 imp:n=1 u=2203 $ Zr/Fuel Gap
2225 119 8.9709E-02 105 -106 159 -155 imp:n=1 u=2203 $ Fuel Rod
2226 11 8.6735E-02 106 -107 -152 imp:n=1 u=2203 $ Top Graphite Reflector
2227 2 5.0820E-05 (-103:104:152) (-104:105:153) (-105:106:155)
(-106:107:152) (103 -108 -156) imp:n=1 u=2203 $ Air Gap
2228 14 8.7412E-02 102 -109 156 -157 imp:n=1 u=2203 $ Cladding
2229 14 8.7412E-02 (108 -158):(108 -109 -156) imp:n=1 u=2203 $ Top End Fitting
2230 1 9.9961E-02 157:(-102 151):(109 158) imp:n=1 u=2203 $ Water
c
c ----- SE Fuel Rod : 11771 -----
2231 14 8.7412E-02 (-103 -151):(102 -103 -156) imp:n=1 u=2204 $ Bottom End Fitting
2232 11 8.6735E-02 103 -104 -152 imp:n=1 u=2204 $ Bottom Graphite Reflector
2233 12 6.4196E-02 104 -105 -153 imp:n=1 u=2204 $ Moly Poison Disc
2234 13 4.3026E-02 105 -106 -154 imp:n=1 u=2204 $ Zirconium Rod
2273 2 5.0820E-05 105 -106 154 -159 imp:n=1 u=2204 $ Zr/Fuel Gap
2235 120 8.9275E-02 105 -106 159 -155 imp:n=1 u=2204 $ Fuel Rod
2236 11 8.6735E-02 106 -107 -152 imp:n=1 u=2204 $ Top Graphite Reflector
2237 2 5.0820E-05 (-103:104:152) (-104:105:153) (-105:106:155)
(-106:107:152) (103 -108 -156) imp:n=1 u=2204 $ Air Gap
2238 14 8.7412E-02 102 -109 156 -157 imp:n=1 u=2204 $ Cladding
2239 14 8.7412E-02 (108 -158):(108 -109 -156) imp:n=1 u=2204 $ Top End Fitting
2240 1 9.9961E-02 157:(-102 151):(109 158) imp:n=1 u=2204 $ Water
c
c ----- Fuel Assembly -----
2241 1 9.9961E-02 -5 imp:n=1 u=2200 $ Water Below Grid Plate
2243 62 7.4744E-02 5 -7 imp:n=1 u=2200 $ Grid Plate With Adapter
2244 33 7.7699E-02 7 -9 imp:n=1 u=2200 $ Lower Adapter
2245 1 9.9961E-02 -132 131 -134 133 imp:n=1 u=2205 lat=1 fill=-1:2 -1:2 0:0 $ Fuel Assemblies
2205 2205 2205 2205
2205 2203 2204 2205
2205 2201 2202 2205
2205 2205 2205 2205
2246 0 9 -10 imp:n=1 u=2200 fill=2205 (-1.9431 -1.9431 0) $ Fuel Bundle
2247 31 9.3070E-02 10 -12 imp:n=1 u=2200 $ Upper Assembly
2248 1 9.9961E-02 12 imp:n=1 u=2200 $ Water Above Core
c
c ----- Position D-5 : 4-Rod Fuel Cluster -----
c ----- NW Fuel Rod : 11790 -----
2301 14 8.7412E-02 (-103 -151):(102 -103 -156) imp:n=1 u=2301 $ Bottom End Fitting
2302 11 8.6735E-02 103 -104 -152 imp:n=1 u=2301 $ Bottom Graphite Reflector
2303 12 6.4196E-02 104 -105 -153 imp:n=1 u=2301 $ Moly Poison Disc
2304 13 4.3026E-02 105 -106 -154 imp:n=1 u=2301 $ Zirconium Rod
2370 2 5.0820E-05 105 -106 154 -159 imp:n=1 u=2301 $ Zr/Fuel Gap
2305 139 8.9600E-02 105 -106 159 -155 imp:n=1 u=2301 $ Fuel Rod
2306 11 8.6735E-02 106 -107 -152 imp:n=1 u=2301 $ Top Graphite Reflector
2307 2 5.0820E-05 (-103:104:152) (-104:105:153) (-105:106:155)
(-106:107:152) (103 -108 -156) imp:n=1 u=2301 $ Air Gap
2308 14 8.7412E-02 102 -109 156 -157 imp:n=1 u=2301 $ Cladding
2309 14 8.7412E-02 (108 -158):(108 -109 -156) imp:n=1 u=2301 $ Top End Fitting
2310 1 9.9961E-02 157:(-102 151):(109 158) imp:n=1 u=2301 $ Water
c
c ----- NE Fuel Rod : 11788 -----
2311 14 8.7412E-02 (-103 -151):(102 -103 -156) imp:n=1 u=2302 $ Bottom End Fitting

```

Fundamental - FUND

NRAD-FUND-RESR-001
CRIT-REAC-COEF

```

2312 11 8.6735E-02 103 -104 -152 imp:n=1 u=2302 $ Bottom Graphite Reflector
2313 12 6.4196E-02 104 -105 -153 imp:n=1 u=2302 $ Moly Poison Disc
2314 13 4.3026E-02 105 -106 -154 imp:n=1 u=2302 $ Zirconium Rod
2371 2 5.0820E-05 105 -106 154 -159 imp:n=1 u=2302 $ Zr/Fuel Gap
2315 137 8.9316E-02 105 -106 159 -155 imp:n=1 u=2302 $ Fuel Rod
2316 11 8.6735E-02 106 -107 -152 imp:n=1 u=2302 $ Top Graphite Reflector
2317 2 5.0820E-05 (-103:104:152) (-104:105:153) (-105:106:155)
(-106:107:152) (103 -108 -156) imp:n=1 u=2302 $ Air Gap
2318 14 8.7412E-02 102 -109 156 -157 imp:n=1 u=2302 $ Cladding
2319 14 8.7412E-02 (108 -158):(108 -109 -156) imp:n=1 u=2302 $ Top End Fitting
2320 1 9.9961E-02 157:(-102 151):(109 158) imp:n=1 u=2302 $ Water
c
c ----- SW Fuel Rod : 11789 -----
2321 14 8.7412E-02 (-103 -151):(102 -103 -156) imp:n=1 u=2303 $ Bottom End Fitting
2322 11 8.6735E-02 103 -104 -152 imp:n=1 u=2303 $ Bottom Graphite Reflector
2323 12 6.4196E-02 104 -105 -153 imp:n=1 u=2303 $ Moly Poison Disc
2324 13 4.3026E-02 105 -106 -154 imp:n=1 u=2303 $ Zirconium Rod
2372 2 5.0820E-05 105 -106 154 -159 imp:n=1 u=2303 $ Zr/Fuel Gap
2325 138 8.9487E-02 105 -106 159 -155 imp:n=1 u=2303 $ Fuel Rod
2326 11 8.6735E-02 106 -107 -152 imp:n=1 u=2303 $ Top Graphite Reflector
2327 2 5.0820E-05 (-103:104:152) (-104:105:153) (-105:106:155)
(-106:107:152) (103 -108 -156) imp:n=1 u=2303 $ Air Gap
2328 14 8.7412E-02 102 -109 156 -157 imp:n=1 u=2303 $ Cladding
2329 14 8.7412E-02 (108 -158):(108 -109 -156) imp:n=1 u=2303 $ Top End Fitting
2330 1 9.9961E-02 157:(-102 151):(109 158) imp:n=1 u=2303 $ Water
c
c ----- SE Fuel Rod : 11791 -----
2331 14 8.7412E-02 (-103 -151):(102 -103 -156) imp:n=1 u=2304 $ Bottom End Fitting
2332 11 8.6735E-02 103 -104 -152 imp:n=1 u=2304 $ Bottom Graphite Reflector
2333 12 6.4196E-02 104 -105 -153 imp:n=1 u=2304 $ Moly Poison Disc
2334 13 4.3026E-02 105 -106 -154 imp:n=1 u=2304 $ Zirconium Rod
2373 2 5.0820E-05 105 -106 154 -159 imp:n=1 u=2304 $ Zr/Fuel Gap
2335 140 8.9007E-02 105 -106 159 -155 imp:n=1 u=2304 $ Fuel Rod
2336 11 8.6735E-02 106 -107 -152 imp:n=1 u=2304 $ Top Graphite Reflector
2337 2 5.0820E-05 (-103:104:152) (-104:105:153) (-105:106:155)
(-106:107:152) (103 -108 -156) imp:n=1 u=2304 $ Air Gap
2338 14 8.7412E-02 102 -109 156 -157 imp:n=1 u=2304 $ Cladding
2339 14 8.7412E-02 (108 -158):(108 -109 -156) imp:n=1 u=2304 $ Top End Fitting
2340 1 9.9961E-02 157:(-102 151):(109 158) imp:n=1 u=2304 $ Water
c
c ----- Fuel Assembly -----
2341 1 9.9961E-02 -5 imp:n=1 u=2300 $ Water Below Grid Plate
2343 62 7.4744E-02 5 -7 imp:n=1 u=2300 $ Grid Plate With Adapter
2344 33 7.7699E-02 7 -9 imp:n=1 u=2300 $ Lower Adapter
2345 1 9.9961E-02 -132 131 -134 133 imp:n=1 u=2305 lat=1 fill=-1:2 -1:2 0:0 $ Fuel Assemblies
2305 2305 2305 2305
2305 2303 2304 2305
2305 2301 2302 2305
2305 2305 2305 2305
2346 0 9 -10 imp:n=1 u=2300 fill=2305 (-1.9431 -1.9431 0) $ Fuel Bundle
2347 31 9.3070E-02 10 -12 imp:n=1 u=2300 $ Upper Assembly
2348 1 9.9961E-02 12 imp:n=1 u=2300 $ Water Above Core
c
c ----- Position D-6 : East Beam Tube Support -----
2401 1 9.9961E-02 -5 imp:n=1 u=2400 $ Water Below Grid Plate
2403 64 7.5685E-02 5 -7 imp:n=1 u=2400 $ Grid Plate With Support
2404 51 9.1752E-02 7 -401 imp:n=1 u=2400 $ Beam Tube Support
2405 1 9.9961E-02 401 imp:n=1 u=2400 $ Water Above Support
c
c ----- Position E-1 : Graphite Reflector -----
2501 1 9.9961E-02 -5 imp:n=1 u=2500 $ Water Below Grid Plate
2503 63 6.9890E-02 5 -7 imp:n=1 u=2500 $ Grid Plate With Adapter
2504 44 7.6788E-02 7 -9 imp:n=1 u=2500 $ Lower Adapter
2505 41 7.8699E-02 (9 -10) (-9:303:354) (-9:303:355) (-9:305:351) (-306:10:356)
(-306:10:357) (331 -332 333 -334) (-335 -336 -337 -338)
imp:n=1 u=2500 $ Graphite Block
2506 42 6.0307E-02 307 -10 -356 imp:n=1 u=2500 $ Top Screw NE
2507 42 6.0307E-02 307 -10 -357 imp:n=1 u=2500 $ Top Screw SW
2508 1 9.9961E-02 306 -307 -356 imp:n=1 u=2500 $ Water in NE Top Hole
2509 1 9.9961E-02 306 -307 -357 imp:n=1 u=2500 $ Water in SW Top Hole
2510 42 6.0307E-02 9 -302 -352 imp:n=1 u=2500 $ Bottom Dowel NE
2511 42 6.0307E-02 9 -302 -353 imp:n=1 u=2500 $ Bottom Dowel SW
2512 42 6.0307E-02 9 -304 -351 imp:n=1 u=2500 $ Tie Rod
2513 1 9.9961E-02 (9 -303 352 -354):(302 -303 -354) imp:n=1 u=2500 $ Water in NE Bottom Hole
2514 1 9.9961E-02 (9 -303 353 -355):(302 -303 -355) imp:n=1 u=2500 $ Water in SW Bottom Hole
2515 1 9.9961E-02 (304 -305 -351) imp:n=1 u=2500 $ Water in Tie Rod Hole

```

Fundamental - FUND

NRAD-FUND-RESR-001
CRIT-REAC-COEF

```

2516 43 9.1820E-02 10 -309 imp:n=1 u=2500 $ Upper Assembly
2517 1 9.9961E-02 309 imp:n=1 u=2500 $ Water Above Core
2518 1 9.9961E-02 (9 -10) (-331:332:-333:334:335:336:337:338) imp:n=1 u=2500 $ Water Around
Assembly
c
c ----- Position E-2 : 4-Rod Fuel Cluster -----
c ----- NW Fuel Rod : 11798 -----
2601 14 8.7412E-02 (-103 -151):(102 -103 -156) imp:n=1 u=2601 $ Bottom End Fitting
2602 11 8.6735E-02 103 -104 -152 imp:n=1 u=2601 $ Bottom Graphite Reflector
2603 12 6.4196E-02 104 -105 -153 imp:n=1 u=2601 $ Moly Poison Disc
2604 13 4.3026E-02 105 -106 -154 imp:n=1 u=2601 $ Zirconium Rod
2670 2 5.0820E-05 105 -106 154 -159 imp:n=1 u=2601 $ Zr/Fuel Gap
2605 147 8.9679E-02 105 -106 159 -155 imp:n=1 u=2601 $ Fuel Rod
2606 11 8.6735E-02 106 -107 -152 imp:n=1 u=2601 $ Top Graphite Reflector
2607 2 5.0820E-05 (-103:104:152) (-104:105:153) (-105:106:155)
(-106:107:152) (103 -108 -156) imp:n=1 u=2601 $ Air Gap
2608 14 8.7412E-02 102 -109 156 -157 imp:n=1 u=2601 $ Cladding
2609 14 8.7412E-02 (108 -158):(108 -109 -156) imp:n=1 u=2601 $ Top End Fitting
2610 1 9.9961E-02 157:(-102 151):(109 158) imp:n=1 u=2601 $ Water
c
c ----- NE Fuel Rod : 11796 -----
2611 14 8.7412E-02 (-103 -151):(102 -103 -156) imp:n=1 u=2602 $ Bottom End Fitting
2612 11 8.6735E-02 103 -104 -152 imp:n=1 u=2602 $ Bottom Graphite Reflector
2613 12 6.4196E-02 104 -105 -153 imp:n=1 u=2602 $ Moly Poison Disc
2614 13 4.3026E-02 105 -106 -154 imp:n=1 u=2602 $ Zirconium Rod
2671 2 5.0820E-05 105 -106 154 -159 imp:n=1 u=2602 $ Zr/Fuel Gap
2615 145 8.9804E-02 105 -106 159 -155 imp:n=1 u=2602 $ Fuel Rod
2616 11 8.6735E-02 106 -107 -152 imp:n=1 u=2602 $ Top Graphite Reflector
2617 2 5.0820E-05 (-103:104:152) (-104:105:153) (-105:106:155)
(-106:107:152) (103 -108 -156) imp:n=1 u=2602 $ Air Gap
2618 14 8.7412E-02 102 -109 156 -157 imp:n=1 u=2602 $ Cladding
2619 14 8.7412E-02 (108 -158):(108 -109 -156) imp:n=1 u=2602 $ Top End Fitting
2620 1 9.9961E-02 157:(-102 151):(109 158) imp:n=1 u=2602 $ Water
c
c ----- SW Fuel Rod : 11799 -----
2621 14 8.7412E-02 (-103 -151):(102 -103 -156) imp:n=1 u=2603 $ Bottom End Fitting
2622 11 8.6735E-02 103 -104 -152 imp:n=1 u=2603 $ Bottom Graphite Reflector
2623 12 6.4196E-02 104 -105 -153 imp:n=1 u=2603 $ Moly Poison Disc
2624 13 4.3026E-02 105 -106 -154 imp:n=1 u=2603 $ Zirconium Rod
2672 2 5.0820E-05 105 -106 154 -159 imp:n=1 u=2603 $ Zr/Fuel Gap
2625 148 8.9451E-02 105 -106 159 -155 imp:n=1 u=2603 $ Fuel Rod
2626 11 8.6735E-02 106 -107 -152 imp:n=1 u=2603 $ Top Graphite Reflector
2627 2 5.0820E-05 (-103:104:152) (-104:105:153) (-105:106:155)
(-106:107:152) (103 -108 -156) imp:n=1 u=2603 $ Air Gap
2628 14 8.7412E-02 102 -109 156 -157 imp:n=1 u=2603 $ Cladding
2629 14 8.7412E-02 (108 -158):(108 -109 -156) imp:n=1 u=2603 $ Top End Fitting
2630 1 9.9961E-02 157:(-102 151):(109 158) imp:n=1 u=2603 $ Water
c
c ----- SE Fuel Rod : 11797 -----
2631 14 8.7412E-02 (-103 -151):(102 -103 -156) imp:n=1 u=2604 $ Bottom End Fitting
2632 11 8.6735E-02 103 -104 -152 imp:n=1 u=2604 $ Bottom Graphite Reflector
2633 12 6.4196E-02 104 -105 -153 imp:n=1 u=2604 $ Moly Poison Disc
2634 13 4.3026E-02 105 -106 -154 imp:n=1 u=2604 $ Zirconium Rod
2673 2 5.0820E-05 105 -106 154 -159 imp:n=1 u=2604 $ Zr/Fuel Gap
2635 146 8.9574E-02 105 -106 159 -155 imp:n=1 u=2604 $ Fuel Rod
2636 11 8.6735E-02 106 -107 -152 imp:n=1 u=2604 $ Top Graphite Reflector
2637 2 5.0820E-05 (-103:104:152) (-104:105:153) (-105:106:155)
(-106:107:152) (103 -108 -156) imp:n=1 u=2604 $ Air Gap
2638 14 8.7412E-02 102 -109 156 -157 imp:n=1 u=2604 $ Cladding
2639 14 8.7412E-02 (108 -158):(108 -109 -156) imp:n=1 u=2604 $ Top End Fitting
2640 1 9.9961E-02 157:(-102 151):(109 158) imp:n=1 u=2604 $ Water
c
c ----- Fuel Assembly -----
2641 1 9.9961E-02 -5 imp:n=1 u=2600 $ Water Below Grid Plate
2643 62 7.4744E-02 5 -7 imp:n=1 u=2600 $ Grid Plate With Adapter
2644 33 7.7699E-02 7 -9 imp:n=1 u=2600 $ Lower Adapter
2645 1 9.9961E-02 -132 131 -134 133 imp:n=1 u=2605 lat=1 fill=-1:2 -1:2 0:0 $ Fuel Assemblies
2605 2605 2605 2605
2605 2603 2604 2605
2605 2601 2602 2605
2605 2605 2605 2605
2646 0 9 -10 imp:n=1 u=2600 fill=2605 (-1.9431 -1.9431 0) $ Fuel Bundle
2647 31 9.3070E-02 10 -12 imp:n=1 u=2600 $ Upper Assembly
2648 1 9.9961E-02 12 imp:n=1 u=2600 $ Water Above Core
c
c ----- Position E-3 : 4-Rod Fuel Cluster -----

```

Fundamental - FUND

NRAD-FUND-RESR-001
CRIT-REAC-COEF

```

c ----- NW Fuel Rod : 11764 ----- ---
2701 14 8.7412E-02 (-103 -151):(102 -103 -156) imp:n=1 u=2701 $ Bottom End Fitting
2702 11 8.6735E-02 103 -104 -152 imp:n=1 u=2701 $ Bottom Graphite Reflector
2703 12 6.4196E-02 104 -105 -153 imp:n=1 u=2701 $ Moly Poison Disc
2704 13 4.3026E-02 105 -106 -154 imp:n=1 u=2701 $ Zirconium Rod
2770 2 5.0820E-05 105 -106 154 -159 imp:n=1 u=2701 $ Zr/Fuel Gap
2705 113 8.9829E-02 105 -106 159 -155 imp:n=1 u=2701 $ Fuel Rod
2706 11 8.6735E-02 106 -107 -152 imp:n=1 u=2701 $ Top Graphite Reflector
2707 2 5.0820E-05 (-103:104:152) (-104:105:153) (-105:106:155)
(-106:107:152) (103 -108 -156) imp:n=1 u=2701 $ Air Gap
2708 14 8.7412E-02 102 -109 156 -157 imp:n=1 u=2701 $ Cladding
2709 14 8.7412E-02 (108 -158):(108 -109 -156) imp:n=1 u=2701 $ Top End Fitting
2710 1 9.9961E-02 157:(-102 151):(109 158) imp:n=1 u=2701 $ Water
c
c ----- NE Fuel Rod : 11765 ----- ---
2711 14 8.7412E-02 (-103 -151):(102 -103 -156) imp:n=1 u=2702 $ Bottom End Fitting
2712 11 8.6735E-02 103 -104 -152 imp:n=1 u=2702 $ Bottom Graphite Reflector
2713 12 6.4196E-02 104 -105 -153 imp:n=1 u=2702 $ Moly Poison Disc
2714 13 4.3026E-02 105 -106 -154 imp:n=1 u=2702 $ Zirconium Rod
2771 2 5.0820E-05 105 -106 154 -159 imp:n=1 u=2702 $ Zr/Fuel Gap
2715 114 8.9802E-02 105 -106 159 -155 imp:n=1 u=2702 $ Fuel Rod
2716 11 8.6735E-02 106 -107 -152 imp:n=1 u=2702 $ Top Graphite Reflector
2717 2 5.0820E-05 (-103:104:152) (-104:105:153) (-105:106:155)
(-106:107:152) (103 -108 -156) imp:n=1 u=2702 $ Air Gap
2718 14 8.7412E-02 102 -109 156 -157 imp:n=1 u=2702 $ Cladding
2719 14 8.7412E-02 (108 -158):(108 -109 -156) imp:n=1 u=2702 $ Top End Fitting
2720 1 9.9961E-02 157:(-102 151):(109 158) imp:n=1 u=2702 $ Water
c
c ----- SW Fuel Rod : 11766 ----- ---
2721 14 8.7412E-02 (-103 -151):(102 -103 -156) imp:n=1 u=2703 $ Bottom End Fitting
2722 11 8.6735E-02 103 -104 -152 imp:n=1 u=2703 $ Bottom Graphite Reflector
2723 12 6.4196E-02 104 -105 -153 imp:n=1 u=2703 $ Moly Poison Disc
2724 13 4.3026E-02 105 -106 -154 imp:n=1 u=2703 $ Zirconium Rod
2772 2 5.0820E-05 105 -106 154 -159 imp:n=1 u=2703 $ Zr/Fuel Gap
2725 115 8.9559E-02 105 -106 159 -155 imp:n=1 u=2703 $ Fuel Rod
2726 11 8.6735E-02 106 -107 -152 imp:n=1 u=2703 $ Top Graphite Reflector
2727 2 5.0820E-05 (-103:104:152) (-104:105:153) (-105:106:155)
(-106:107:152) (103 -108 -156) imp:n=1 u=2703 $ Air Gap
2728 14 8.7412E-02 102 -109 156 -157 imp:n=1 u=2703 $ Cladding
2729 14 8.7412E-02 (108 -158):(108 -109 -156) imp:n=1 u=2703 $ Top End Fitting
2730 1 9.9961E-02 157:(-102 151):(109 158) imp:n=1 u=2703 $ Water
c
c ----- SE Fuel Rod : 11767 ----- ---
2731 14 8.7412E-02 (-103 -151):(102 -103 -156) imp:n=1 u=2704 $ Bottom End Fitting
2732 11 8.6735E-02 103 -104 -152 imp:n=1 u=2704 $ Bottom Graphite Reflector
2733 12 6.4196E-02 104 -105 -153 imp:n=1 u=2704 $ Moly Poison Disc
2734 13 4.3026E-02 105 -106 -154 imp:n=1 u=2704 $ Zirconium Rod
2773 2 5.0820E-05 105 -106 154 -159 imp:n=1 u=2704 $ Zr/Fuel Gap
2735 116 8.9156E-02 105 -106 159 -155 imp:n=1 u=2704 $ Fuel Rod
2736 11 8.6735E-02 106 -107 -152 imp:n=1 u=2704 $ Top Graphite Reflector
2737 2 5.0820E-05 (-103:104:152) (-104:105:153) (-105:106:155)
(-106:107:152) (103 -108 -156) imp:n=1 u=2704 $ Air Gap
2738 14 8.7412E-02 102 -109 156 -157 imp:n=1 u=2704 $ Cladding
2739 14 8.7412E-02 (108 -158):(108 -109 -156) imp:n=1 u=2704 $ Top End Fitting
2740 1 9.9961E-02 157:(-102 151):(109 158) imp:n=1 u=2704 $ Water
c
c ----- Fuel Assembly -----
2741 1 9.9961E-02 -5 imp:n=1 u=2700 $ Water Below Grid Plate
2743 62 7.4744E-02 5 -7 imp:n=1 u=2700 $ Grid Plate With Adapter
2744 33 7.7699E-02 7 -9 imp:n=1 u=2700 $ Lower Adapter
2745 1 9.9961E-02 -132 131 -134 133 imp:n=1 u=2705 lat=1 fill=-1:2 -1:2 0:0 $ Fuel Assemblies
2705 2705 2705 2705
2705 2703 2704 2705
2705 2701 2702 2705
2705 2705 2705 2705
2746 0 9 -10 imp:n=1 u=2700 fill=2705 (-1.9431 -1.9431 0) $ Fuel Bundle
2747 31 9.3070E-02 10 -12 imp:n=1 u=2700 $ Upper Assembly
2748 1 9.9961E-02 12 imp:n=1 u=2700 $ Water Above Core
c
c ----- Position E-4 : Regulating Rod Control Cluster -----
c ----- NW Fuel Rod : 11758 ----- ---
2801 14 8.7412E-02 (-103 -151):(102 -103 -156) imp:n=1 u=2801 $ Bottom End Fitting
2802 11 8.6735E-02 103 -104 -152 imp:n=1 u=2801 $ Bottom Graphite Reflector
2803 12 6.4196E-02 104 -105 -153 imp:n=1 u=2801 $ Moly Poison Disc
2804 13 4.3026E-02 105 -106 -154 imp:n=1 u=2801 $ Zirconium Rod
2870 2 5.0820E-05 105 -106 154 -159 imp:n=1 u=2801 $ Zr/Fuel Gap

```

Fundamental - FUND

NRAD-FUND-RESR-001
CRIT-REAC-COEF

```

2805 107 8.9626E-02 105 -106 159 -155 imp:n=1 u=2801 $ Fuel Rod
2806 11 8.6735E-02 106 -107 -152 imp:n=1 u=2801 $ Top Graphite Reflector
2807 2 5.0820E-05 (-103:104:152) (-104:105:153) (-105:106:155)
(-106:107:152) (103 -108 -156) imp:n=1 u=2801 $ Air Gap
2808 14 8.7412E-02 102 -109 156 -157 imp:n=1 u=2801 $ Cladding
2809 14 8.7412E-02 (108 -158):(108 -109 -156) imp:n=1 u=2801 $ Top End Fitting
2810 1 9.9961E-02 157:(-102 151):(109 158) imp:n=1 u=2801 $ Water
c
c ----- NE Control Rod : Reg -----
2811 14 8.7412E-02 -201 -251 imp:n=1 u=2802 $ Bottom End Fitting
2812 23 6.7723E-02 201 -202 -253 imp:n=1 u=2802 $ Guide Tube Bottom
2813 25 6.1351E-02 202 -203 252 -253 imp:n=1 u=2802 $ Guide Tube
2814 1 9.9961E-02 (-201 251):253:(203 252) imp:n=1 u=2802 $ Water Outside Guide Tube
c
2850 22 5.9939E-02 231 -232 -275 imp:n=1 u=2806 $ Bottom End Fitting
2851 21 1.3514E-01 232 -233 -271 imp:n=1 u=2806 $ Absorber
2852 22 5.9939E-02 233 -234 272 -271 imp:n=1 u=2806 $ Spacer Disc
2853 22 5.9939E-02 234 -235 273 -274 imp:n=1 u=2806 $ Spacer Tube
2854 0 (232 -234 271 -275):(233 -234 -272):(234 -235 -273):(234 -235 274 -275)
imp:n=1 u=2806 $ Void Space
2855 22 5.9939E-02 (235 -236 -275):(236 -237 -277) imp:n=1 u=2806 $ Top End Fitting
2856 22 5.9939E-02 231 -236 275 -276 imp:n=1 u=2806 $ Cladding
2857 24 6.8709E-02 237 -238 -278 imp:n=1 u=2806 $ Attachment Interface
2858 2 5.0820E-05 238 -239 -279 imp:n=1 u=2806 $ Inside Extension Rod
2859 22 5.9939E-02 238 -239 279 -280 imp:n=1 u=2806 $ Extension Rod
2860 1 9.9961E-02 (-231 -276):(276):(236 278):(238 280):(236 -237 277):(239)
imp:n=1 u=2806 $ Water around Control Rod
c
c ----- SW Fuel Rod : 11759 -----
2821 14 8.7412E-02 (-103 -151):(102 -103 -156) imp:n=1 u=2803 $ Bottom End Fitting
2822 11 8.6735E-02 103 -104 -152 imp:n=1 u=2803 $ Bottom Graphite Reflector
2823 12 6.4196E-02 104 -105 -153 imp:n=1 u=2803 $ Moly Poison Disc
2824 13 4.3026E-02 105 -106 -154 imp:n=1 u=2803 $ Zirconium Rod
2872 2 5.0820E-05 105 -106 154 -159 imp:n=1 u=2803 $ Zr/Fuel Gap
2825 108 8.9895E-02 105 -106 159 -155 imp:n=1 u=2803 $ Fuel Rod
2826 11 8.6735E-02 106 -107 -152 imp:n=1 u=2803 $ Top Graphite Reflector
2827 2 5.0820E-05 (-103:104:152) (-104:105:153) (-105:106:155)
(-106:107:152) (103 -108 -156) imp:n=1 u=2803 $ Air Gap
2828 14 8.7412E-02 102 -109 156 -157 imp:n=1 u=2803 $ Cladding
2829 14 8.7412E-02 (108 -158):(108 -109 -156) imp:n=1 u=2803 $ Top End Fitting
2830 1 9.9961E-02 157:(-102 151):(109 158) imp:n=1 u=2803 $ Water
c
c ----- SE Fuel Rod : 11760 -----
2831 14 8.7412E-02 (-103 -151):(102 -103 -156) imp:n=1 u=2804 $ Bottom End Fitting
2832 11 8.6735E-02 103 -104 -152 imp:n=1 u=2804 $ Bottom Graphite Reflector
2833 12 6.4196E-02 104 -105 -153 imp:n=1 u=2804 $ Moly Poison Disc
2834 13 4.3026E-02 105 -106 -154 imp:n=1 u=2804 $ Zirconium Rod
2873 2 5.0820E-05 105 -106 154 -159 imp:n=1 u=2804 $ Zr/Fuel Gap
2835 109 8.9164E-02 105 -106 159 -155 imp:n=1 u=2804 $ Fuel Rod
2836 11 8.6735E-02 106 -107 -152 imp:n=1 u=2804 $ Top Graphite Reflector
2837 2 5.0820E-05 (-103:104:152) (-104:105:153) (-105:106:155)
(-106:107:152) (103 -108 -156) imp:n=1 u=2804 $ Air Gap
2838 14 8.7412E-02 102 -109 156 -157 imp:n=1 u=2804 $ Cladding
2839 14 8.7412E-02 (108 -158):(108 -109 -156) imp:n=1 u=2804 $ Top End Fitting
2840 1 9.9961E-02 157:(-102 151):(109 158) imp:n=1 u=2804 $ Water
c
c ----- Fuel Assembly -----
2841 1 9.9961E-02 -5 imp:n=1 u=2800 $ Water Below Grid Plate
2843 62 7.4744E-02 5 -7 imp:n=1 u=2800 $ Grid Plate With Adapter
2844 33 7.7699E-02 7 -9 imp:n=1 u=2800 $ Lower Adapter
2845 1 9.9961E-02 -132 131 -134 133 imp:n=1 u=2805 lat=1 fill=-1:2 -1:2 0:0 $ Fuel Assemblies
2805 2805 2805 2805
2805 2803 2804 2805
2805 2801 2802 2805
2805 2805 2805 2805
2846 0 9 -10 imp:n=1 u=2800 fill=2805 (-1.9431 -1.9431 0) $ Fuel Bundle
2847 32 9.1839E-02 10 -12 262 imp:n=1 u=2800 $ Upper Assembly
2848 1 9.9961E-02 12 262 imp:n=1 u=2800 $ Water Above Core
2849 0 10 -262 imp:n=1 u=2800 fill=2805 (-1.9431 -1.9431 0)
c
c ----- Position E-5 : 4-Rod Fuel Cluster -----
c ----- NW Fuel Rod : 11804 -----
2901 14 8.7412E-02 (-103 -151):(102 -103 -156) imp:n=1 u=2901 $ Bottom End Fitting
2902 11 8.6735E-02 103 -104 -152 imp:n=1 u=2901 $ Bottom Graphite Reflector
2903 12 6.4196E-02 104 -105 -153 imp:n=1 u=2901 $ Moly Poison Disc
2904 13 4.3026E-02 105 -106 -154 imp:n=1 u=2901 $ Zirconium Rod

```

Fundamental - FUND

NRAD-FUND-RESR-001
CRIT-REAC-COEF

```

2970 2 5.0820E-05 105 -106 154 -159 imp:n=1 u=2901 $ Zr/Fuel Gap
2905 153 8.9001E-02 105 -106 159 -155 imp:n=1 u=2901 $ Fuel Rod
2906 11 8.6735E-02 106 -107 -152 imp:n=1 u=2901 $ Top Graphite Reflector
2907 2 5.0820E-05 (-103:104:152) (-104:105:153) (-105:106:155)
(-106:107:152) (103 -108 -156) imp:n=1 u=2901 $ Air Gap
2908 14 8.7412E-02 102 -109 156 -157 imp:n=1 u=2901 $ Cladding
2909 14 8.7412E-02 (108 -158):(108 -109 -156) imp:n=1 u=2901 $ Top End Fitting
2910 1 9.9961E-02 157:(-102 151):(109 158) imp:n=1 u=2901 $ Water
c
c ----- NE Fuel Rod : 11806 -----
2911 14 8.7412E-02 (-103 -151):(102 -103 -156) imp:n=1 u=2902 $ Bottom End Fitting
2912 11 8.6735E-02 103 -104 -152 imp:n=1 u=2902 $ Bottom Graphite Reflector
2913 12 6.4196E-02 104 -105 -153 imp:n=1 u=2902 $ Moly Poison Disc
2914 13 4.3026E-02 105 -106 -154 imp:n=1 u=2902 $ Zirconium Rod
2971 2 5.0820E-05 105 -106 154 -159 imp:n=1 u=2902 $ Zr/Fuel Gap
2915 155 8.9409E-02 105 -106 159 -155 imp:n=1 u=2902 $ Fuel Rod
2916 11 8.6735E-02 106 -107 -152 imp:n=1 u=2902 $ Top Graphite Reflector
2917 2 5.0820E-05 (-103:104:152) (-104:105:153) (-105:106:155)
(-106:107:152) (103 -108 -156) imp:n=1 u=2902 $ Air Gap
2918 14 8.7412E-02 102 -109 156 -157 imp:n=1 u=2902 $ Cladding
2919 14 8.7412E-02 (108 -158):(108 -109 -156) imp:n=1 u=2902 $ Top End Fitting
2920 1 9.9961E-02 157:(-102 151):(109 158) imp:n=1 u=2902 $ Water
c
c ----- SW Fuel Rod : 11805 -----
2921 14 8.7412E-02 (-103 -151):(102 -103 -156) imp:n=1 u=2903 $ Bottom End Fitting
2922 11 8.6735E-02 103 -104 -152 imp:n=1 u=2903 $ Bottom Graphite Reflector
2923 12 6.4196E-02 104 -105 -153 imp:n=1 u=2903 $ Moly Poison Disc
2924 13 4.3026E-02 105 -106 -154 imp:n=1 u=2903 $ Zirconium Rod
2972 2 5.0820E-05 105 -106 154 -159 imp:n=1 u=2903 $ Zr/Fuel Gap
2925 154 8.9470E-02 105 -106 159 -155 imp:n=1 u=2903 $ Fuel Rod
2926 11 8.6735E-02 106 -107 -152 imp:n=1 u=2903 $ Top Graphite Reflector
2927 2 5.0820E-05 (-103:104:152) (-104:105:153) (-105:106:155)
(-106:107:152) (103 -108 -156) imp:n=1 u=2903 $ Air Gap
2928 14 8.7412E-02 102 -109 156 -157 imp:n=1 u=2903 $ Cladding
2929 14 8.7412E-02 (108 -158):(108 -109 -156) imp:n=1 u=2903 $ Top End Fitting
2930 1 9.9961E-02 157:(-102 151):(109 158) imp:n=1 u=2903 $ Water
c
c ----- SE Fuel Rod : 11807 -----
2931 14 8.7412E-02 (-103 -151):(102 -103 -156) imp:n=1 u=2904 $ Bottom End Fitting
2932 11 8.6735E-02 103 -104 -152 imp:n=1 u=2904 $ Bottom Graphite Reflector
2933 12 6.4196E-02 104 -105 -153 imp:n=1 u=2904 $ Moly Poison Disc
2934 13 4.3026E-02 105 -106 -154 imp:n=1 u=2904 $ Zirconium Rod
2973 2 5.0820E-05 105 -106 154 -159 imp:n=1 u=2904 $ Zr/Fuel Gap
2935 156 8.9534E-02 105 -106 159 -155 imp:n=1 u=2904 $ Fuel Rod
2936 11 8.6735E-02 106 -107 -152 imp:n=1 u=2904 $ Top Graphite Reflector
2937 2 5.0820E-05 (-103:104:152) (-104:105:153) (-105:106:155)
(-106:107:152) (103 -108 -156) imp:n=1 u=2904 $ Air Gap
2938 14 8.7412E-02 102 -109 156 -157 imp:n=1 u=2904 $ Cladding
2939 14 8.7412E-02 (108 -158):(108 -109 -156) imp:n=1 u=2904 $ Top End Fitting
2940 1 9.9961E-02 157:(-102 151):(109 158) imp:n=1 u=2904 $ Water
c
c ----- Fuel Assembly -----
2941 1 9.9961E-02 -5 imp:n=1 u=2900 $ Water Below Grid Plate
2943 62 7.4744E-02 5 -7 imp:n=1 u=2900 $ Grid Plate With Adapter
2944 33 7.7699E-02 7 -9 imp:n=1 u=2900 $ Lower Adapter
2945 1 9.9961E-02 -132 131 -134 133 imp:n=1 u=2905 lat=1 fill=-1:2 -1:2 0:0 $ Fuel Assemblies
2905 2905 2905 2905
2905 2903 2904 2905
2905 2901 2902 2905
2905 2905 2905 2905
2946 0 9 -10 imp:n=1 u=2900 fill=2905 (-1.9431 -1.9431 0) $ Fuel Bundle
2947 31 9.3070E-02 10 -12 imp:n=1 u=2900 $ Upper Assembly
2948 1 9.9961E-02 12 imp:n=1 u=2900 $ Water Above Core
c
c ----- Position E-6 : Graphite Reflector -----
3001 1 9.9961E-02 -5 imp:n=1 u=3000 $ Water Below Grid Plate
3003 63 6.9890E-02 5 -7 imp:n=1 u=3000 $ Grid Plate With Adapter
3004 44 7.6788E-02 7 -9 imp:n=1 u=3000 $ Lower Adapter
3005 41 7.8699E-02 (9 -10) (-9:303:354) (-9:303:355) (-9:305:351) (-306:10:356)
(-306:10:357) (331 -332 333 -334) (-335 -336 -337 -338)
imp:n=1 u=3000 $ Graphite Block
3006 42 6.0307E-02 307 -10 -356 imp:n=1 u=3000 $ Top Screw NE
3007 42 6.0307E-02 307 -10 -357 imp:n=1 u=3000 $ Top Screw SW
3008 1 9.9961E-02 306 -307 -356 imp:n=1 u=3000 $ Water in NE Top Hole
3009 1 9.9961E-02 306 -307 -357 imp:n=1 u=3000 $ Water in SW Top Hole
3010 42 6.0307E-02 9 -302 -352 imp:n=1 u=3000 $ Bottom Dowel NE

```

Fundamental - FUND

NRAD-FUND-RESR-001
CRIT-REAC-COEF

```

3011 42 6.0307E-02 9 -302 -353 imp:n=1 u=3000 $ Bottom Dowel SW
3012 42 6.0307E-02 9 -304 -351 imp:n=1 u=3000 $ Tie Rod
3013 1 9.9961E-02 (9 -303 352 -354):(302 -303 -354) imp:n=1 u=3000 $ Water in NE Bottom Hole
3014 1 9.9961E-02 (9 -303 353 -355):(302 -303 -355) imp:n=1 u=3000 $ Water in SW Bottom Hole
3015 1 9.9961E-02 (304 -305 -351) imp:n=1 u=3000 $ Water in Tie Rod Hole
3016 43 9.1820E-02 10 -309 imp:n=1 u=3000 $ Upper Assembly
3017 1 9.9961E-02 309 imp:n=1 u=3000 $ Water Above Core
3018 1 9.9961E-02 (9 -10) (-331:332:-333:334:335:336:337:338) imp:n=1 u=3000 $ Water Around
Assembly
c
c ----- Position F-1 : Empty Position -----
3101 1 9.9961E-02 -5 imp:n=1 u=3100 $ Water Below Grid Plate
3102 61 8.0867E-02 5 -7 imp:n=1 u=3100 $ Empty Grid Plate Position
3103 1 9.9961E-02 7 imp:n=1 u=3100 $ Water Above Core
c
c ----- Position F-2 : Graphite Reflector -----
3201 1 9.9961E-02 -5 imp:n=1 u=3200 $ Water Below Grid Plate
3203 63 6.9890E-02 5 -7 imp:n=1 u=3200 $ Grid Plate With Adapter
3204 44 7.6788E-02 7 -9 imp:n=1 u=3200 $ Lower Adapter
3205 41 7.8699E-02 (9 -10) (-9:303:354) (-9:303:355) (-9:305:351) (-306:10:356)
(-306:10:357) (331 -332 333 -334) (-335 -336 -337 -338)
imp:n=1 u=3200 $ Graphite Block
3206 42 6.0307E-02 307 -10 -356 imp:n=1 u=3200 $ Top Screw NE
3207 42 6.0307E-02 307 -10 -357 imp:n=1 u=3200 $ Top Screw SW
3208 1 9.9961E-02 306 -307 -356 imp:n=1 u=3200 $ Water in NE Top Hole
3209 1 9.9961E-02 306 -307 -357 imp:n=1 u=3200 $ Water in SW Top Hole
3210 42 6.0307E-02 9 -302 -352 imp:n=1 u=3200 $ Bottom Dowel NE
3211 42 6.0307E-02 9 -302 -353 imp:n=1 u=3200 $ Bottom Dowel SW
3212 42 6.0307E-02 9 -304 -351 imp:n=1 u=3200 $ Tie Rod
3213 1 9.9961E-02 (9 -303 352 -354):(302 -303 -354) imp:n=1 u=3200 $ Water in NE Bottom Hole
3214 1 9.9961E-02 (9 -303 353 -355):(302 -303 -355) imp:n=1 u=3200 $ Water in SW Bottom Hole
3215 1 9.9961E-02 (304 -305 -351) imp:n=1 u=3200 $ Water in Tie Rod Hole
3216 43 9.1820E-02 10 -309 imp:n=1 u=3200 $ Upper Assembly
3217 1 9.9961E-02 309 imp:n=1 u=3200 $ Water Above Core
3218 1 9.9961E-02 (9 -10) (-331:332:-333:334:335:336:337:338) imp:n=1 u=3200 $ Water Around
Assembly
c
c ----- Position F-3 : Graphite Reflector (AmBe Source) -----
3301 1 9.9961E-02 -5 imp:n=1 u=3300 $ Water Below Grid Plate
3303 63 6.9890E-02 5 -7 imp:n=1 u=3300 $ Grid Plate With Adapter
3304 44 7.6788E-02 7 -9 imp:n=1 u=3300 $ Lower Adapter
3305 41 7.8699E-02 (9 -10) (-9:303:354) (-9:303:355) (-9:305:351) (-306:10:356)
(-306:10:357) (331 -332 333 -334) (-335 -336 -337 -338)
(-321:322:372) (341:376) (-322:371) imp:n=1 u=3300 $ Graphite Block
3306 42 6.0307E-02 307 -10 -356 imp:n=1 u=3300 $ Top Screw NE
3307 42 6.0307E-02 307 -10 -357 imp:n=1 u=3300 $ Top Screw SW
3308 1 9.9961E-02 306 -307 -356 imp:n=1 u=3300 $ Water in NE Top Hole
3309 1 9.9961E-02 306 -307 -357 imp:n=1 u=3300 $ Water in SW Top Hole
3310 42 6.0307E-02 9 -302 -352 imp:n=1 u=3300 $ Bottom Dowel NE
3311 42 6.0307E-02 9 -302 -353 imp:n=1 u=3300 $ Bottom Dowel SW
3312 42 6.0307E-02 9 -304 -351 imp:n=1 u=3300 $ Tie Rod
3313 1 9.9961E-02 (9 -303 352 -354):(302 -303 -354) imp:n=1 u=3300 $ Water in NE Bottom Hole
3314 1 9.9961E-02 (9 -303 353 -355):(302 -303 -355) imp:n=1 u=3300 $ Water in SW Bottom Hole
3315 1 9.9961E-02 (304 -305 -351) imp:n=1 u=3300 $ Water in Tie Rod Hole
3316 47 9.0981E-02 10 -309 375 imp:n=1 u=3300 $ Upper Assembly
3317 1 9.9961E-02 309 imp:n=1 u=3300 $ Water Above Core
3318 1 9.9961E-02 (9 -10) (-331:332:-333:334:335:336:337:338) imp:n=1 u=3300 $ Water Around
Assembly
c
3331 1 9.9961E-02 (-341 333 -376):(321 -322 -372):(373 -371 322 -324)
imp:n=1 u=3300 $ Water in Source Hole
3332 22 5.9939E-02 ((-323:325:374) 322 -326 -373 (-322:323:372) (341:377))
:(326 -327 342 -343 344 -345):(324 -326 -375 373)
imp:n=1 u=3300 $ Source Tube
3333 1 9.9961E-02 ((-341 -371 -377):(322 -323 -372):(323 -325 -374))
(-323:313:362):(10 -324 371 -375) imp:n=1 u=3300 $ Water in Source Tube
3334 1 9.9961E-02 (-326:327:-342:343:-344:345) 326 -309 -375 imp:n=1 u=3300 $ Water Above Source
Tube
3335 46 8.7653E-02 (-311:312:361) 323 -313 -362 imp:n=1 u=3300 $ Source Capsule
3336 45 4.1093E-03 311 -312 -361 imp:n=1 u=3300 $ Smearred AmBe Source
c
c ----- Position F-4 : Graphite Reflector -----
3401 1 9.9961E-02 -5 imp:n=1 u=3400 $ Water Below Grid Plate
3403 63 6.9890E-02 5 -7 imp:n=1 u=3400 $ Grid Plate With Adapter
3404 44 7.6788E-02 7 -9 imp:n=1 u=3400 $ Lower Adapter
3405 41 7.8699E-02 (9 -10) (-9:303:354) (-9:303:355) (-9:305:351) (-306:10:356)

```

Fundamental - FUND

NRAD-FUND-RESR-001
CRIT-REAC-COEF

```

(-306:10:357) (331 -332 333 -334) (-335 -336 -337 -338)
imp:n=1 u=3400 $ Graphite Block
3406 42 6.0307E-02 307 -10 -356 imp:n=1 u=3400 $ Top Screw NE
3407 42 6.0307E-02 307 -10 -357 imp:n=1 u=3400 $ Top Screw SW
3408 1 9.9961E-02 306 -307 -356 imp:n=1 u=3400 $ Water in NE Top Hole
3409 1 9.9961E-02 306 -307 -357 imp:n=1 u=3400 $ Water in SW Top Hole
3410 42 6.0307E-02 9 -302 -352 imp:n=1 u=3400 $ Bottom Dowel NE
3411 42 6.0307E-02 9 -302 -353 imp:n=1 u=3400 $ Bottom Dowel SW
3412 42 6.0307E-02 9 -304 -351 imp:n=1 u=3400 $ Tie Rod
3413 1 9.9961E-02 (9 -303 352 -354):(302 -303 -354) imp:n=1 u=3400 $ Water in NE Bottom Hole
3414 1 9.9961E-02 (9 -303 353 -355):(302 -303 -355) imp:n=1 u=3400 $ Water in SW Bottom Hole
3415 1 9.9961E-02 (304 -305 -351) imp:n=1 u=3400 $ Water in Tie Rod Hole
3416 43 9.1820E-02 10 -309 imp:n=1 u=3400 $ Upper Assembly
3417 1 9.9961E-02 309 imp:n=1 u=3400 $ Water Above Core
3418 1 9.9961E-02 (9 -10) (-331:332:-333:334:335:336:337:338) imp:n=1 u=3400 $ Water Around
Assembly
c
c ----- Position F-5 : Graphite Reflector -----
3501 1 9.9961E-02 -5 imp:n=1 u=3500 $ Water Below Grid Plate
3503 63 6.9890E-02 5 -7 imp:n=1 u=3500 $ Grid Plate With Adapter
3504 44 7.6788E-02 7 -9 imp:n=1 u=3500 $ Lower Adapter
3505 41 7.8699E-02 (9 -10) (-9:303:354) (-9:303:355) (-9:305:351) (-306:10:356)
(-306:10:357) (331 -332 333 -334) (-335 -336 -337 -338)
imp:n=1 u=3500 $ Graphite Block
3506 42 6.0307E-02 307 -10 -356 imp:n=1 u=3500 $ Top Screw NE
3507 42 6.0307E-02 307 -10 -357 imp:n=1 u=3500 $ Top Screw SW
3508 1 9.9961E-02 306 -307 -356 imp:n=1 u=3500 $ Water in NE Top Hole
3509 1 9.9961E-02 306 -307 -357 imp:n=1 u=3500 $ Water in SW Top Hole
3510 42 6.0307E-02 9 -302 -352 imp:n=1 u=3500 $ Bottom Dowel NE
3511 42 6.0307E-02 9 -302 -353 imp:n=1 u=3500 $ Bottom Dowel SW
3512 42 6.0307E-02 9 -304 -351 imp:n=1 u=3500 $ Tie Rod
3513 1 9.9961E-02 (9 -303 352 -354):(302 -303 -354) imp:n=1 u=3500 $ Water in NE Bottom Hole
3514 1 9.9961E-02 (9 -303 353 -355):(302 -303 -355) imp:n=1 u=3500 $ Water in SW Bottom Hole
3515 1 9.9961E-02 (304 -305 -351) imp:n=1 u=3500 $ Water in Tie Rod Hole
3516 43 9.1820E-02 10 -309 imp:n=1 u=3500 $ Upper Assembly
3517 1 9.9961E-02 309 imp:n=1 u=3500 $ Water Above Core
3518 1 9.9961E-02 (9 -10) (-331:332:-333:334:335:336:337:338) imp:n=1 u=3500 $ Water Around
Assembly
c
c ----- Position F-6 : Empty Position -----
3601 1 9.9961E-02 -5 imp:n=1 u=3600 $ Water Below Grid Plate
3602 61 8.0867E-02 5 -7 imp:n=1 u=3600 $ Empty Grid Plate Position
3603 1 9.9961E-02 7 imp:n=1 u=3600 $ Water Above Core
c
c --- Beam Lines -----
c ----- East Beam Line -----
3701 2 5.0820E-05 (404 -405 436 -437 435 -434):(434 -442 -601) imp:n=1 $ Air in Beam Filter
Tube
3702 52 5.9939E-02 (-404:405:-436:437:-435) 402 -403 432 -433 431 -434 imp:n=1 $ Beam Filter
Tube
3703 52 5.9939E-02 (-402:403:-432:433:434) (438 -447 439 -440 406 -407)
(601:442) (-441:-445:446) imp:n=1 $ Beam Filter Tube Attachment Fixtures
3704 52 5.9939E-02 441 -444 445 -446 408 -13 (-447:448:-449:450:-409)
(601:-443:447) (602:-448:451) imp:n=1 $ Beam Aperture Housing
3705 53 1.2258E-06 ((447 -448 449 -450 409 -13):(443 -447 -601):
(448 -451 -602)) (-410:413:-459:448:-455:456) imp:n=1 $ Helium in Aperture
Housing
3706 54 1.0026E-01 444 -452 631 -632 imp:n=1 $ Absorber Disc Aperture
3707 53 1.2258E-06 444 -452 -631 imp:n=1 $ Helium in Disc Aperture
3708 52 5.9939E-02 452 -454 -606 (603:-453) imp:n=1 $ Beam Stop
3709 53 1.2258E-06 -633 459 -448 imp:n=1 $ Helium in Bottom Aperture Hole
3710 53 1.2258E-06 -634 459 -448 imp:n=1 $ Helium in Top Aperture Hole
3711 54 1.0026E-01 460 -461 457 -458 411 -412 633 634 imp:n=1 $ Absorber Aperture Block
3712 52 5.9939E-02 (-460:461:-457:458:-411:412) 459 -448 455 -456 410 -413
633 634 imp:n=1 $ Absorber Assembly Housing
c
3770 52 5.9939E-02 (444 604 -605 -71):((444:-445:446) 448 -444 -605) imp:n=1 $ Beam Tube
3771 53 1.2258E-06 444 -604 -71 (-444:452:632) (-452:454:606) : (453 -454 -603)
imp:n=1 $ Helium in Beam Tube
c
c ----- North Beam Line -----
3801 53 1.2258E-06 (404 -405 536 -537 535 -534):(534 -542 -651) imp:n=1 $ Helium in Beam Filter
Tube
3802 52 5.9939E-02 (-404:405:-536:537:-535) 402 -403 532 -533 531 -534 imp:n=1 $ Beam Filter
Tube
3803 52 5.9939E-02 (-402:403:-532:533:534) (538 -547 539 -540 406 -407)

```

Fundamental - FUND

NRAD-FUND-RESR-001
CRIT-REAC-COEF

```

(651:542) (-541:-545:546) imp:n=1 $ Beam Filter Tube Attachment Fixtures
3804 52 5.9939E-02 541 -544 545 -546 408 -13 (-547:548:-549:550:-409)
(651:-543:547) (652:-548:551) imp:n=1 $ Beam Aperture Housing
3805 53 1.2258E-06 ((547 -548 549 -550 409 -13):(543 -547 -651):
(548 -551 -652)) (-410:413:-559:548:-555:556) imp:n=1 $ Helium in Aperture
Housing
3806 54 1.0026E-01 544 -552 671 -672 imp:n=1 $ Absorber Disc Aperture
3807 53 1.2258E-06 544 -552 -671 imp:n=1 $ Helium in Disc Aperture
3808 52 5.9939E-02 552 -554 -656 (653:-553) imp:n=1 $ Beam Stop
3809 53 1.2258E-06 -673 559 -548 imp:n=1 $ Helium in Bottom Aperture Hole
3810 53 1.2258E-06 -674 559 -548 imp:n=1 $ Helium in Top Aperture Hole
3811 54 1.0026E-01 560 -561 557 -558 411 -412 673 674 imp:n=1 $ Absorber Aperture Block
3812 52 5.9939E-02 (-560:561:-557:558:-411:412) 559 -548 555 -556 410 -413
673 674 imp:n=1 $ Absorber Assembly Housing
c
3870 52 5.9939E-02 (544 654 -655 -71):((544:-545:546) 548 -544 -655) imp:n=1 $ Beam Tube
3871 53 1.2258E-06 544 -654 -71 (-544:552:672) (-552:554:656)
:(553 -554 -653) imp:n=1 $ Helium in Beam Tube
c
c --- NRAD Reactor Core -----
c ----- Core Map -----
3901 1 9.9961E-02 -32 31 -34 33 imp:n=1 u=3900 lat=1 fill=-4:5 -4:5 0:0
3900 3900 3900 3900 3900 3900 3900 3900 3900 3900 3900
3900 3100 3100 3100 3100 3600 3600 3600 3600 3900
3900 3100 3100 3200 3300 3400 3500 3600 3600 3900
3900 3100 2500 2600 2700 2800 2900 3000 3600 3900
3900 3100 1900 2000 2100 2200 2300 2400 3600 3900
3900 100 1300 1400 1500 1600 1700 1800 600 3900
3900 100 700 800 900 1000 1100 1200 600 3900
3900 100 100 200 300 400 500 600 600 3900
3900 100 100 100 100 600 600 600 600 3900
3900 3900 3900 3900 3900 3900 3900 3900 3900 3900
c
c ----- Core Map Legend -----
c H2O H2O H2O H2O H2O H2O H2O H2O H2O H2O
c H2O Grid Grid Grid Grid Grid Grid Grid Grid H2O
c H2O Grid Grid Grph Srce Grph Grph Grid Grid H2O
c H2O Grid Grph Fuel Fuel Reg Fuel Grph Grid H2O
c H2O Grid Grph Shm1 Fuel Fuel Fuel EaBm Grid H2O
c H2O Grid Grph Shm2 Fuel Hole Fuel EaBm Grid H2O
c H2O Grid Grph Fuel Fuel Fuel Fuel Grph Grid H2O
c H2O Grid Grid Grph NoBm NoBm Grph Grid Grid H2O
c H2O Grid Grid Grid Grid Grid Grid Grid Grid H2O
c H2O H2O H2O H2O H2O H2O H2O H2O H2O H2O
c
c EaBm = East Beam Support
c Fuel = Four Fuel Cluster
c Grid = Empty Grid Position (or Grid Edge)
c Grph = Graphite Block Reflector
c H2O = Water
c Hole = Water Hole (Irradiation Position)
c NoBm = North Beam Support
c Reg = Regulating Rod Cluster
c Shm1 = Shim Rod 1 Cluster
c Shm2 = Shim Rod 2 Cluster
c Srce = Graphite Block Reflector with AmBe Source
c
c ----- Core Map Positions -----
c H2O H2O H2O H2O H2O H2O H2O H2O H2O H2O
c H2O Grid Grid Grid Grid Grid Grid Grid Grid H2O
c H2O Grid F-1 F-2 F-3 F-4 F-5 F-6 Grid H2O
c H2O Grid E-1 E-2 E-3 E-4 E-5 E-6 Grid H2O
c H2O Grid D-1 D-2 D-3 D-4 D-5 D-6 Grid H2O
c H2O Grid C-1 C-2 C-3 C-4 C-5 C-6 Grid H2O
c H2O Grid B-1 B-2 B-3 B-4 B-5 B-6 Grid H2O
c H2O Grid A-1 A-2 A-3 A-4 A-5 A-6 Grid H2O
c H2O Grid Grid Grid Grid Grid Grid Grid Grid H2O
c H2O H2O H2O H2O H2O H2O H2O H2O H2O H2O
c
c Note: Visual Core Map is Mirrored Vertically Compared to Actual Positions
c
3902 0 (-36 35 -38 37 -13 3) (-402:403:-532:533:-531) (-402:403:-432:433:-431)
imp:n=1 fill=3900 (-4.05003 -3.85445 0)
c
c --- Ex-Core Components -----
4001 65 8.2064E-02 (3 -6 -40 39 -42 41) (36:-35:38:-37) imp:n=1 $ Support Structure

```

Fundamental - FUND

NRAD-FUND-RESR-001
CRIT-REAC-COEF

```

4002 1 9.9961E-02 (6 -13 -40 39 -42 41) (36:-35:38:-37)
      (-402:403:-532:533:-531) (-402:403:-432:433:-431) imp:n=1 $ Water Above Support
structure
c
4011 66 5.9939E-02 2 -3 -71 imp:n=1 $ Mounting Pad
c
4021 66 5.9939E-02 1 -13 -72 (-2:71) imp:n=1 $ Tank
c
c ----- Tank Water -----
4101 1 9.9961E-02 (40:-39:42:-41) (3 -13 -71 51 -52) (-402:403:-532:533:534)
      (-538:547:-539:540:-406:407) (-541:544:-545:546:-408)
      (-548:655)
      imp:n=1 $ NW Tank Quadrant
4102 1 9.9961E-02 (40:-39:42:-41) (3 -13 -71 51 52) (-402:403:-532:533:534)
      (-402:403:-432:433:434) (-438:447:-439:440:-406:407)
      (-441:444:-445:446:-408) (-448:605)
      (-538:547:-539:540:-406:407) (-541:544:-545:546:-408)
      (-548:655) imp:n=1 $ NE Tank Quadrant
4103 1 9.9961E-02 (40:-39:42:-41) (3 -13 -71 -51 -52) imp:n=1 $ SW Tank Quadrant
4104 1 9.9961E-02 (40:-39:42:-41) (3 -13 -71 -51 52) (-402:403:-432:433:434)
      (-438:447:-439:440:-406:407) (-441:444:-445:446:-408)
      (-448:605) imp:n=1 $ SE Tank Quadrant
c
c --- Model Boundary -----
9999 0 -1:13:72 imp:n=0
c

c Surface Cards *****
c --- Primary Model Dimensions -----
c ----- Horizontal Planes -----
1    pz    0      $ Tank Bottom Surface
2    pz    1.27   $ Tank/Mounting Pad Interface
3    pz    3.81   $ Mounting Pad Top Surface/Bottom of Support Structure
5    pz    45.95876 $ Bottom of Grid Plate Structure
6    pz    51.03876 $ Top of Support Structure and Grid Plate Bolt Plates
7    pz    58.65876 $ Top of Grid Plate Structure
9    pz    62.46876 $ Top of Lower Adapter Assembly
10   pz    128.19127 $ Bottom of Upper Handle Assembly
12   pz    140.89127 $ Top of Upper Handle Assembly
13   pz    203.2   $ Tank Water Top Boundary
c
c ----- Vertical Planes -----
31   px    -4.05003 $ West Assembly Boundary
32   px     4.05003 $ East Assembly Boundary
33   py    -3.85445 $ South Assembly Boundary
34   py     3.85445 $ North Assembly Boundary
35   px    -24.31415 $ West Side of Grid Plate
36   px     24.31415 $ East Side of Grid Plate
37   py    -23.33625 $ South Side of Grid Plate
38   py     23.33625 $ North Side of Grid Plate
39   px    -27.49042 $ West Side of Support Structure
40   px     27.49042 $ East Side of Support Structure
41   py    -26.51125 $ South Side of Support Structure
42   py     26.51125 $ North Side of Support Structure
c
51   py     0      $ N/S Division of Tank
52   px     0      $ E/W Division of Tank
c
c ----- Radii -----
71   cz    99.06   $ Inner Tank Surface
72   cz    99.695  $ Outer Tank Surface
c
c --- Fuel Rods -----
c ----- Horizontal Planes -----
102  pz    67.54876 $ Bottom of Clad Tube
103  pz    68.81876 $ Bottom End Fitting/Bottom Graphite Reflector Interface
104  pz    77.50556 $ Bottom Graphite Reflector/Moly Disc Interface
105  pz    77.584935 $ Moly Disc/Fuel Rods Interface
106  pz    115.604935 $ Fuel Rods/Top Graphite Reflector Interface
107  pz    124.291735 $ Top Graphite Reflector/Air Gap Interface
108  pz    125.01627 $ Air Gap/Top End Fitting Interface
109  pz    126.28627 $ Top of Clad Tube
c
c ----- Vertical Planes -----
131  px    -1.9431  $ West Fuel Boundary
132  px     1.9431  $ East Fuel Boundary

```

Fundamental - FUND

NRAD-FUND-RESR-001
CRIT-REAC-COEF

```

133 py -1.9431 $ South Fuel Boundary
134 py 1.9431 $ North Fuel Boundary
c
c ----- Radii -----
151 cz 1.27 $ Bottom End Fitting
152 cz 1.63957 $ Axial Graphite Reflectors
153 cz 1.73482 $ Moly Poison Disc
154 cz 0.28575 $ Zirconium Rods
155 cz 1.74025 $ Fuel Rod OD
156 cz 1.7447 $ Cladding Inner Surface
157 cz 1.7955 $ Cladding Outer Surface
158 cz 1.6764 $ Top End Fitting
159 cz 0.3175 $ Fuel Rod ID
c
c --- Control Rods -----
c ----- Horizontal Planes -----
201 pz 71.35876 $ Bottom End Fitting/Guide Tube Interface
202 pz 73.89876 $ Inside Bottom of Guide Tube
203 pz 163.91636 $ Top of Guide Tube
c
231 pz 76.12126 $ Bottom of Control Rod Clad
232 pz 77.70876 $ Clad/B4C Rod Interface
233 pz 115.80876 $ B4C Rod/Spacer Interface
234 pz 117.07876 $ Spacer/Void Interface
235 pz 133.58876 $ Void/Clad Interface
236 pz 135.55726 $ Top of Control Rod Clad
237 pz 137.14476 $ Top End Fitting/Attachment Region Interface
238 pz 145.08226 $ Attachment Region/Extension Rod Interface
239 pz 230.80726 $ Top of Extension Rod
c
c ----- Radii -----
251 cz 1.27 $ Bottom End Fitting
252 cz 1.7399 $ Guide Tube Inner Surface
253 cz 1.8796 $ Guide Tube Outer Surface
c
261 c/z -1.9431 1.9431 1.88 $ NW Control Rod Cut Out
262 c/z 1.9431 1.9431 1.88 $ NE Control Rod Cut Out
263 c/z -1.9431 -1.9431 1.88 $ SW Control Rod Cut Out
264 c/z 1.9431 -1.9431 1.88 $ SE Control Rod Cut Out
c
271 cz 1.50749 $ B4C/Spacer Outer Surface
272 cz 0.635 $ Spacer Hole
273 cz 1.33985 $ Void Tube Inner Surface
274 cz 1.42875 $ Void Tube Outer Surface
275 cz 1.51638 $ Cladding Inner Surface
276 cz 1.5875 $ Cladding Outer Surface
277 cz 0.88773 $ Top End Fitting
278 cz 1.42875 $ Rod Attachment Region
279 cz 0.80645 $ Extension Rod Inner Surface
280 cz 1.11125 $ Extension Rod Outer Surface
c
c --- Graphite Reflector Assemblies -----
c ----- Horizontal Planes -----
302 pz 64.37376 $ Top of Dowel Pins
303 pz 64.69126 $ Top of Dowel Pin Holes
304 pz 65.32626 $ Top of Tie Rod
305 pz 65.64376 $ Top of Tie Rod Hole
306 pz 124.38126 $ Bottom of Screw Holes
307 pz 125.01626 $ Bottom of Screws
309 pz 141.04366 $ Top of Upper Handle Assembly
c
311 pz 95.16999 $ Inside Bottom of AmBe Source
312 pz 98.35515 $ Inside Top of AmBe Source
313 pz 98.5139 $ Outside Top of AmBe Source
c
321 pz 91.99626 $ Bottom of Water Hole in Graphite
322 pz 93.26626 $ Bottom of Source Hole/Source Tube
323 pz 95.01124 $ Inside Bottom of Source Tube
324 pz 131.52628 $ Bottom of Source Tube Cap
325 pz 135.81126 $ Inside Top of Source Tube Cap
326 pz 136.76376 $ Top of Source Tube Cap
327 pz 139.30376 $ Tip of Source Tube Cap
c
c ----- Vertical Planes -----
331 px -3.683 $ West Graphite Surface
332 px 3.683 $ East Graphite Surface

```

Fundamental - FUND

NRAD-FUND-RESR-001
CRIT-REAC-COEF

```

333 py -3.683 $ South Graphite Surface
334 py 3.683 $ North Graphite Surface
335 p -3.683 2.7305 1 -3.683 2.7305 -1 -2.7305 3.683 1 $ NW Chamfer
336 p 3.683 2.7305 1 3.683 2.7305 -1 2.7305 3.683 1 $ NE Chamfer
337 p -3.683 -2.7305 1 -3.683 -2.7305 -1 -2.7305 -3.683 1 $ SW Chamfer
338 p 3.683 -2.7305 1 3.683 -2.7305 -1 2.7305 -3.683 1 $ SE Chamfer
c
341 py -1.82372 $ Cutoff Surface for Water Hole in Graphite
342 px 1.18872 $ West Source Tube Cap Tip
343 px 2.45872 $ East Source Tube Cap Tip
344 py -2.45872 $ South Source Tube Cap Tip
345 py -1.18872 $ North Source Tube Cap Tip
c
c ----- Radii -----
351 cz 0.79375 $ Tie Rod/Tie Rod Hole
352 c/z 1.9431 1.9431 0.81915 $ Dowel NE
353 c/z -1.9431 -1.9431 0.81915 $ Dowel SW
354 c/z 1.9431 1.9431 0.83312 $ Dowel Hole NE
355 c/z -1.9431 -1.9431 0.83312 $ Dowel Hole SW
356 c/z 1.9431 1.9431 0.79375 $ Screw/Screw Hole NE
357 c/z -1.9431 -1.9431 0.79375 $ Screw/Screw Hole SW
c
361 c/z 1.82372 -1.82372 0.889 $ Inside Surface of AmBe Source
362 c/z 1.82372 -1.82372 1.04775 $ Outside Surface of AmBe Source
c
371 c/z 1.82372 -1.82372 1.34874 $ Source Hole
372 c/z 1.82372 -1.82372 0.3175 $ Water Holes in Graphite and Source Tube
373 c/z 1.82372 -1.82372 1.34874 $ Source Tube Outer Surface
374 c/z 1.82372 -1.82372 1.22936 $ Source Tube Inner Surface
375 c/z 1.82372 -1.82372 1.82499 $ Source Tube Cap Outer Surface
376 c/y 1.82372 92.31376 0.3175 $ Water Interconnect Hole in Graphite
377 c/y 1.82372 94.13875 0.23749 $ Water Interconnect Hole in Source Tube
c
c --- Beam Lines -----
c ----- Horizontal Planes -----
401 pz 84.455 $ Top of Beam Tube Support
402 pz 88.33993 $ Bottom Surface of Beam Filter Tubes
403 pz 104.84993 $ Top Surface of Beam Filter Tubes
404 pz 88.97493 $ Inside Bottom Surface of Beam Filter Tubes
405 pz 104.21493 $ Inside Top Surface of Beam Filter Tubes
406 pz 83.25993 $ Bottom Surface of Tube Attachment Fixtures
407 pz 109.92993 $ Top Surface of Tube Attachment Fixtures
408 pz 80.71993 $ Outside Bottom Surface of Aperture Housing
409 pz 81.98993 $ Inside Bottom Surface of Aperture Housing
410 pz 90.08618 $ Bottom of Absorber Assembly
411 pz 91.51493 $ Bottom of Absorber Block
412 pz 108.65993 $ Top of Absorber Block
413 pz 111.67618 $ Top of Absorber Assembly
c
c ----- Vertical Planes -----
c ----- East Beam Assembly -----
431 px 17.92069 $ Core Face of Beam Filter Tube
432 py -6.985 $ South Surface of Beam Filter Tube
433 py 6.985 $ North Surface of Beam Filter Tube
434 px 51.57569 $ Back End of Beam Filter Tube
435 px 18.14929 $ Inside Core Face of Beam Filter Tube
436 py -6.6675 $ Inside South Surface of Beam Filter Tube
437 py 6.6675 $ Inside North Surface of Beam Filter Tube
438 px 47.76569 $ Beam Filter Tube Attachment Fixtures
439 py -10.4775 $ South Surface of Tube Attachment Fixtures
440 py 10.4775 $ North Surface of Tube Attachment Fixtures
441 px 52.84569 $ Core-Side Face of Beam Aperture Housing
442 px 52.52819 $ Beam Window Surface on Filter Tube
443 px 53.16319 $ Beam Window Surface on Aperture Housing
444 px 64.27569 $ Tank-Side Face of Beam Aperture Housing
445 py -7.9375 $ South Surface of Aperture Housing
446 py 7.9375 $ North Surface of Aperture Housing
447 px 54.11569 $ Inside Core-Side Face of Aperture Housing
448 px 63.00569 $ Inside Tank-Side Face of Aperture Housing
449 py -6.6675 $ Inside South Surface of Aperture Housing
450 py 6.6675 $ Inside North Surface of Aperture Housing
451 px 64.19949 $ Beam Window Surface on Aperture Housing
452 px 69.35569 $ Disc Absorber/Stop Interface
453 px 69.51317 $ Beam Window Surface in Absorber Stop
454 px 69.99069 $ Tank-Side Face of Absorber Stop
455 py -6.62686 $ South Surface of Absorber Assembly

```

Fundamental - FUND

NRAD-FUND-RESR-001
CRIT-REAC-COEF

456 py 6.62686 \$ North Surface of Absorber Assembly
 457 py -5.08 \$ South Surface of Absorber Block
 458 py 5.08 \$ North Surface of Absorber Block
 459 px 57.29069 \$ Core-Side Face of Absorber Assembly
 460 px 57.60819 \$ Core-Side Face of Absorber Block
 461 px 62.68819 \$ Tank-Side Face of Absorber Block
 c
 c ----- North Beam Assembly -----
 531 py 17.33395 \$ Core Face of West Beam Filter Tube
 532 px -6.985 \$ East Surface of West Beam Filter Tube
 533 px 6.985 \$ West Surface of West Beam Filter Tube
 534 py 52.57645 \$ Back End of Beam Filter Tube
 535 py 17.56255 \$ Inside Core Face of Beam Filter Tube
 536 px -6.6675 \$ Inside East Surface of Beam Filter Tube
 537 px 6.6675 \$ Inside West Surface of Beam Filter Tube
 538 py 48.76645 \$ Beam Filter Tube Attachment Fixtures
 539 px -10.4775 \$ East Surface of Tube Attachment Fixtures
 540 px 10.4775 \$ West Surface of Tube Attachment Fixtures
 541 py 53.84645 \$ Core-Side Face of Beam Aperture Housing
 542 py 53.52895 \$ Beam Window Surface on Filter Tube
 543 py 54.16395 \$ Beam Window Surface on Aperture Housing
 544 py 65.27645 \$ Tank-Side Face of Beam Aperture Housing
 545 px -7.9375 \$ East Surface of Aperture Housing
 546 px 7.9375 \$ West Surface of Aperture Housing
 547 py 55.11645 \$ Inside Core-Side Face of Aperture Housing
 548 py 64.00645 \$ Inside Tank-Side Face of Aperture Housing
 549 px -6.6675 \$ Inside East Surface of Aperture Housing
 550 px 6.6675 \$ Inside West Surface of Aperture Housing
 551 py 65.20025 \$ Beam Window Surface on Aperture Housing
 552 py 70.35645 \$ Disc Absorber/Stop Interface
 553 py 70.51393 \$ Beam Window Surface in Absorber Stop
 554 py 70.99145 \$ Tank-Side Face of Absorber Stop
 555 px -6.62686 \$ East Surface of Absorber Assembly
 556 px 6.62686 \$ West Surface of Absorber Assembly
 557 px -5.08 \$ East Surface of Absorber Block
 558 px 5.08 \$ West Surface of Absorber Block
 559 py 58.29145 \$ Core-Side Face of Absorber Assembly
 560 py 58.60895 \$ Core-Side Face of Absorber Block
 561 py 63.68895 \$ Tank-Side Face of Absorber Block
 c

c ----- Radii -----
 c ----- East Beam Assembly -----
 601 c/x 0 96.59493 5.3975 \$ Beam Filter Window
 602 c/x 0 96.59493 4.52374 \$ Beam Tube Window
 603 c/x 0 96.59493 5.715 \$ Beam Tube Window
 604 c/x 0 96.59493 10.16 \$ Beam Tube Inner Surface
 605 c/x 0 96.59493 11.43 \$ Beam Tube Outer Surface
 606 c/x 0 96.59493 10.11936 \$ Beam Tube Absorber Stop
 c
 631 c/x 0 96.59793 4.445 \$ Disc Absorber Inner Hole
 632 c/x 0 96.59793 10.1346 \$ Disc Absorber Outer Surface
 633 c/x 0 96.59793 1.77165 \$ Bottom Hole in Block Absorber
 634 c/x 0 103.57993 0.7366 \$ Top Hole in Block Absorber
 c

c ----- North Beam Assembly -----
 651 c/y 0 96.59493 5.3975 \$ Beam Filter Window
 652 c/y 0 96.59493 4.52374 \$ Beam Tube Window
 653 c/y 0 96.59493 5.715 \$ Beam Tube Window
 654 c/y 0 96.59493 10.16 \$ Beam Tube Inner Surface
 655 c/y 0 96.59493 11.43 \$ Beam Tube Outer Surface
 656 c/y 0 96.59493 10.11936 \$ Beam Tube Absorber Stop
 c
 671 c/y 0 96.59793 4.445 \$ Disc Absorber Inner Hole
 672 c/y 0 96.59793 10.1346 \$ Disc Absorber Outer Surface
 673 c/y 0 96.59793 1.77165 \$ Bottom Hole in Block Absorber
 674 c/y 0 103.57993 0.7366 \$ Top Hole in Block Absorber
 c

c Data Cards *****

c *** Material Cards *****

c --- Water -----
 m1 1001.70c 6.6633E-02 1002.70c 7.6637E-06 8016.70c 3.3308E-02
 8017.70c 1.2662E-05
 c Total 9.9961E-02
 mt1 lwtr.10t hwtr.10t

Fundamental - FUND

NRAD-FUND-RESR-001
CRIT-REAC-COEF

c						
c ---	Air -----					
m2	1001.70c	5.0303E-07	1002.70c	5.7856E-11	7014.70c	3.9123E-05
	7015.70c	1.4451E-07	8016.70c	1.0800E-05	8017.70c	4.1056E-09
	18036.70c	7.9027E-10	18038.70c	1.4843E-10	18040.70c	2.3391E-07
	6000.70c	9.5977E-09	2003.70c	1.8051E-16	2004.70c	1.3176E-10
	36078.70c	1.0033E-13	36080.70c	6.5356E-13	36082.70c	3.3194E-12
	36083.70c	3.2936E-12	36084.70c	1.6339E-11	36086.70c	4.9590E-12
c	Total	5.0820E-05				
mt2	lwtr.10t	hwtr.10t				
c						
c ---	Fuel Rods (Non-Fuel Components) -----					
c -----	Axial Graphite Reflectors -----					
m11	3006.70c	2.8481E-10	3007.70c	3.4676E-09	4009.70c	2.8900E-09
	5010.70c	6.7120E-09	5011.70c	2.7016E-08	6000.70c	8.6734E-02
	9019.70c	2.7419E-09	11023.70c	1.1329E-09	12024.70c	8.4647E-10
	12025.70c	1.0716E-10	12026.70c	1.1798E-10	13027.70c	9.6531E-10
	14028.70c	2.5659E-08	14029.70c	1.3029E-09	14030.70c	8.5889E-10
	15031.70c	1.6818E-09	16032.70c	2.8372E-08	16033.70c	2.2714E-10
	16034.70c	1.2822E-09	16036.70c	5.9774E-12	17035.70c	5.3445E-09
	17037.70c	1.7082E-09	19039.70c	1.2425E-09	19040.70c	1.5588E-13
	19041.70c	8.9667E-11	20040.70c	6.2999E-10	20042.70c	4.2047E-12
	20043.70c	8.7733E-13	20044.70c	1.3556E-11	20046.70c	2.5995E-14
	20048.70c	1.2153E-12	21045.70c	1.1587E-10	22046.70c	8.9756E-12
	22047.70c	8.0944E-12	22048.70c	8.0204E-11	22049.70c	5.8858E-12
	22050.70c	5.6356E-12	23000.70c	1.0226E-10	24050.70c	2.1765E-10
	24052.70c	4.1971E-09	24053.70c	4.7592E-10	24054.70c	1.1847E-10
	25055.70c	9.4818E-11	26054.70c	5.4519E-12	26056.70c	8.5583E-11
	26057.70c	1.9765E-12	26058.70c	2.6303E-13	27059.70c	8.8390E-11
	28058.70c	6.0423E-11	28060.70c	2.3275E-11	28061.70c	1.0117E-12
	28062.70c	3.2259E-12	28064.70c	8.2153E-13	29063.70c	2.8351E-10
	29065.70c	1.2636E-10	30000.70c	3.9831E-10	31069.70c	4.4908E-11
	31071.70c	2.9804E-11	32070.70c	7.4754E-11	32072.70c	9.8787E-11
	32073.70c	2.7728E-11	32074.70c	1.3014E-10	32076.70c	2.7297E-11
	33075.70c	3.4764E-10	34074.70c	2.9357E-12	34076.70c	3.0908E-11
	34077.70c	2.5168E-11	34078.70c	7.8407E-11	34080.70c	1.6364E-10
	34082.70c	2.8797E-11	35079.70c	3.3046E-10	35081.70c	3.2146E-10
	37085.70c	2.1993E-10	37087.70c	8.4810E-11	38084.70c	1.6646E-12
	38086.70c	2.9309E-11	38087.70c	2.0808E-11	38088.70c	2.4547E-10
	39089.70c	2.9296E-10	40090.70c	1.4690E-10	40091.70c	3.2034E-11
	40092.70c	4.8965E-11	40094.70c	4.9622E-11	40096.70c	7.9943E-12
	41093.70c	2.8034E-10	42092.70c	4.0287E-11	42094.70c	2.5112E-11
	42095.70c	4.3219E-11	42096.70c	4.5283E-11	42097.70c	2.5926E-11
	42098.70c	6.5508E-11	42100.70c	2.6143E-11	44096.70c	1.4276E-11
	44098.70c	4.8190E-12	44099.70c	3.2882E-11	44100.70c	3.2470E-11
	44101.70c	4.3963E-11	44102.70c	8.1304E-11	44104.70c	4.7983E-11
	45103.70c	5.0620E-11	46102.70c	2.4964E-12	46104.70c	2.7264E-11
	46105.70c	5.4651E-11	46106.70c	6.6888E-11	46108.70c	6.4759E-11
	46110.70c	2.8684E-11	47107.70c	1.2517E-10	47109.70c	1.1629E-10
	48106.70c	2.8963E-12	48108.70c	2.0621E-12	48110.70c	2.8940E-11
	48111.70c	2.9658E-11	48112.70c	5.5910E-11	48113.70c	2.8314E-11
	48114.70c	6.6568E-11	48116.70c	1.7354E-11	49113.70c	9.7314E-12
	49115.70c	2.1711E-10	50112.70c	2.1282E-12	50114.70c	1.4481E-12
	50115.70c	7.4598E-13	50116.70c	3.1902E-11	50117.70c	1.6850E-11
	50118.70c	5.3140E-11	50119.70c	1.8847E-11	50120.70c	7.1482E-11
	50122.70c	1.0158E-11	50124.70c	1.2704E-11	51121.70c	1.2239E-10
	51123.70c	9.1539E-11	52120.70c	1.8371E-13	52122.70c	5.2050E-12
	52123.70c	1.8167E-12	52124.70c	9.6752E-12	52125.70c	1.4431E-11
	52126.70c	3.8456E-11	52128.70c	6.4787E-11	52130.70c	6.9564E-11
	53127.70c	4.1048E-11	55133.70c	1.9597E-10	56130.70c	2.0104E-13
	56132.70c	1.9156E-13	56134.70c	4.5841E-12	56135.70c	1.2502E-11
	56136.70c	1.4896E-11	56137.70c	2.1303E-11	56138.70c	1.3598E-10
	57138.70c	1.6876E-13	57139.70c	1.8734E-10	58136.70c	3.4389E-13
	58138.70c	4.6658E-13	58140.70c	1.6442E-10	58142.70c	2.0660E-11
	59141.70c	1.8484E-10	60142.70c	4.9115E-11	60143.70c	2.2030E-11
	60144.70c	4.2976E-11	60145.70c	1.4987E-11	60146.70c	3.1058E-11
	60148.70c	1.0293E-11	60150.70c	1.0112E-11	62144.70c	1.0636E-12
	62147.70c	5.1932E-12	62148.70c	3.8940E-12	62149.70c	4.7878E-12
	62150.70c	2.5567E-12	62152.70c	9.2673E-12	62154.70c	7.8816E-12
	63151.70c	1.6389E-11	63153.70c	1.7890E-11	64152.70c	6.6253E-14
	64154.70c	7.2215E-13	64155.70c	4.9027E-12	64156.70c	6.7810E-12
	64157.70c	5.1843E-12	64158.70c	8.2286E-12	64160.70c	7.2414E-12
	65159.70c	3.2777E-11	66156.70c	1.9234E-14	66158.70c	3.2056E-14
	66160.70c	7.5011E-13	66161.70c	6.0618E-12	66162.70c	8.1775E-12
	66163.70c	7.9820E-12	66164.70c	9.0334E-12	67165.70c	3.1584E-11
	68162.70c	4.3601E-14	68164.70c	5.0142E-13	68166.70c	1.0467E-11

Fundamental - FUND

NRAD-FUND-RESR-001
CRIT-REAC-COEF

68167.70c	7.1413E-12	68168.70c	8.3403E-12	68170.70c	4.6498E-12	
69169.55c	3.0835E-11	5010.70c	4.0640E-15	71175.70c	2.9001E-11	
71176.70c	7.7109E-13	72174.70c	4.6695E-14	72176.70c	1.5351E-12	
72177.70c	5.4283E-12	72178.70c	7.9615E-12	72179.70c	3.9749E-12	
72180.70c	1.0238E-11	73181.70c	2.8788E-07	74182.70c	3.7542E-11	
74183.70c	2.0273E-11	74184.70c	4.3407E-11	74186.70c	4.0446E-11	
75185.70c	1.0463E-11	75187.70c	1.7512E-11	76000.31c	2.7388E-11	
77191.70c	1.0108E-11	77193.70c	1.6992E-11	78000.31c	2.6702E-11	
79197.70c	2.6447E-10	80196.70c	3.8953E-13	80198.70c	2.5891E-11	
80199.70c	4.3810E-11	80200.70c	5.9988E-11	80201.70c	3.4227E-11	
80202.70c	7.7543E-11	80204.70c	1.7841E-11	81000.31c	1.2743E-10	
82204.70c	1.7598E-12	82206.70c	3.0294E-11	82207.70c	2.7780E-11	
82208.70c	6.5868E-11	83209.70c	1.2463E-10	90232.70c	1.1225E-10	
92234.70c	6.0182E-15	92235.70c	7.8784E-13	92238.70c	1.0863E-10	
c	Total	8.6735E-02				
mt11	grp10t					
c						
c	----- Moly Poison Disc -----					
m12	3006.70c	3.3650E-10	3007.70c	4.0970E-09	4009.70c	3.4146E-09
	5010.70c	5.6644E-10	5011.70c	2.2800E-09	6000.70c	5.1241E-05
	9019.70c	1.6198E-09	11023.70c	7.7234E-07	12024.70c	7.4008E-08
	12025.70c	9.3693E-09	12026.70c	1.0316E-08	13027.70c	1.0037E-07
	14028.70c	4.0422E-07	14029.70c	2.0525E-08	14030.70c	1.3530E-08
	15031.70c	1.0134E-07	16032.70c	3.5434E-07	16033.70c	2.8368E-09
	16034.70c	1.6013E-08	16036.70c	7.4653E-11	17035.70c	1.3155E-09
	17037.70c	4.2046E-10	19039.70c	3.6700E-06	19040.70c	4.6043E-10
	19041.70c	2.6486E-07	20040.70c	2.6796E-07	20042.70c	1.7884E-09
	20043.70c	3.7316E-10	20044.70c	5.7661E-09	20046.70c	1.1057E-11
	20048.70c	5.1690E-10	21045.70c	3.4226E-10	22046.70c	5.3024E-08
	22047.70c	4.7818E-08	22048.70c	4.7381E-07	22049.70c	3.4771E-08
	22050.70c	3.3292E-08	23000.70c	1.3290E-07	24050.70c	1.9543E-08
	24052.70c	3.7688E-07	24053.70c	4.2735E-08	24054.70c	1.0638E-08
	25055.70c	4.8172E-08	26054.70c	7.5687E-08	26056.70c	1.1881E-06
	26057.70c	2.7439E-08	26058.70c	3.6516E-09	27059.70c	1.4621E-08
	28058.70c	8.5667E-08	28060.70c	3.2999E-08	28061.70c	1.4344E-09
	28062.70c	4.5736E-09	28064.70c	1.1648E-09	29063.70c	1.6748E-07
	29065.70c	7.4649E-08	30000.70c	2.3530E-09	31069.70c	1.3265E-09
	31071.70c	8.8034E-10	32070.70c	8.8322E-10	32072.70c	1.1672E-09
	32073.70c	3.2761E-10	32074.70c	1.5376E-09	32076.70c	3.2252E-10
	33075.70c	2.8751E-08	34074.70c	3.4686E-11	34076.70c	3.6518E-10
	34077.70c	2.9736E-10	34078.70c	9.2638E-10	34080.70c	1.9334E-09
	34082.70c	3.4023E-10	35079.70c	1.9522E-10	35081.70c	1.8990E-10
	37085.70c	1.2993E-09	37087.70c	5.0101E-10	38084.70c	9.8339E-11
	38086.70c	1.7315E-09	38087.70c	1.2292E-09	38088.70c	1.4501E-08
	39089.70c	3.4613E-09	40090.70c	1.7356E-09	40091.70c	3.7849E-10
	40092.70c	5.7853E-10	40094.70c	5.8629E-10	40096.70c	9.4453E-11
	41093.70c	1.6561E-08	42092.70c	9.5169E-03	42094.70c	5.9320E-03
	42095.70c	1.0210E-02	42096.70c	1.0697E-02	42097.70c	6.1244E-03
	42098.70c	1.5475E-02	42100.70c	6.1757E-03	44096.70c	8.4339E-11
	44098.70c	2.8468E-11	44099.70c	1.9425E-10	44100.70c	1.9182E-10
	44101.70c	2.5971E-10	44102.70c	4.8030E-10	44104.70c	2.8346E-10
	45103.70c	1.4952E-09	46102.70c	2.9495E-11	46104.70c	3.2213E-10
	46105.70c	6.4571E-10	46106.70c	7.9029E-10	46108.70c	7.6513E-10
	46110.70c	3.3890E-10	47107.70c	7.3944E-09	47109.70c	6.8697E-09
	48106.70c	3.4220E-09	48108.70c	2.4364E-09	48110.70c	3.4192E-08
	48111.70c	3.5041E-08	48112.70c	6.6057E-08	48113.70c	3.3453E-08
	48114.70c	7.8650E-08	48116.70c	2.0504E-08	49113.70c	5.7488E-11
	49115.70c	1.2826E-09	50112.70c	9.5551E-11	50114.70c	6.5014E-11
	50115.70c	3.3492E-11	50116.70c	1.4323E-09	50117.70c	7.5653E-10
	50118.70c	2.3858E-09	50119.70c	8.4617E-10	50120.70c	3.2093E-09
	50122.70c	4.5609E-10	50124.70c	5.7035E-10	51121.70c	3.7596E-08
	51123.70c	2.8120E-08	52120.70c	1.0853E-12	52122.70c	3.0749E-11
	52123.70c	1.0732E-11	52124.70c	5.7157E-11	52125.70c	8.5253E-11
	52126.70c	2.2718E-10	52128.70c	3.8273E-10	52130.70c	4.1095E-10
	53127.70c	2.4249E-10	55133.70c	1.1577E-09	56130.70c	7.1259E-10
	56132.70c	6.7898E-10	56134.70c	1.6248E-08	56135.70c	4.4315E-08
	56136.70c	5.2799E-08	56137.70c	7.5508E-08	56138.70c	4.8199E-07
	57138.70c	3.7684E-11	57139.70c	4.1833E-08	58136.70c	2.0315E-12
	58138.70c	2.7563E-12	58140.70c	9.7130E-10	58142.70c	1.2205E-10
	59141.70c	2.1839E-10	60142.70c	5.8030E-11	60143.70c	2.6028E-11
	60144.70c	5.0776E-11	60145.70c	1.7708E-11	60146.70c	3.6695E-11
	60148.70c	1.2161E-11	60150.70c	1.1947E-11	62144.70c	6.2831E-12
	62147.70c	3.0679E-11	62148.70c	2.3004E-11	62149.70c	2.8284E-11
	62150.70c	1.5104E-11	62152.70c	5.4747E-11	62154.70c	4.6561E-11
	63151.70c	9.6818E-11	63153.70c	1.0569E-10	64152.70c	3.9139E-13
	64154.70c	4.2661E-12	64155.70c	2.8963E-11	64156.70c	4.0059E-11

Fundamental - FUND

NRAD-FUND-RESR-001
CRIT-REAC-COEF

64157.70c	3.0626E-11	64158.70c	4.8610E-11	64160.70c	4.2779E-11	
65159.70c	1.9363E-10	66156.70c	1.1362E-13	66158.70c	1.8937E-13	
66160.70c	4.4313E-12	66161.70c	3.5810E-11	66162.70c	4.8309E-11	
66163.70c	4.7154E-11	66164.70c	5.3365E-11	67165.70c	1.8658E-10	
68162.70c	2.5758E-13	68164.70c	2.9621E-12	68166.70c	6.1837E-11	
68167.70c	4.2187E-11	68168.70c	4.9271E-11	68170.70c	2.7469E-11	
69169.55c	1.8216E-10	5010.70c	2.4008E-14	71175.70c	1.7132E-10	
71176.70c	4.5553E-12	72174.70c	2.7585E-13	72176.70c	9.0686E-12	
72177.70c	3.2068E-11	72178.70c	4.7033E-11	72179.70c	2.3482E-11	
72180.70c	6.0480E-11	73181.70c	1.7007E-07	74182.70c	1.1089E-06	
74183.70c	5.9880E-07	74184.70c	1.2821E-06	74186.70c	1.1947E-06	
75185.70c	1.6070E-09	75187.70c	2.6898E-09	76000.31c	8.0896E-10	
77191.70c	2.9857E-10	77193.70c	5.0189E-10	78000.31c	7.8873E-10	
79197.70c	7.8117E-10	80196.70c	1.1506E-12	80198.70c	7.6476E-11	
80199.70c	1.2940E-10	80200.70c	1.7719E-10	80201.70c	1.0110E-10	
80202.70c	2.2904E-10	80204.70c	5.2697E-11	81000.31c	7.5282E-10	
82204.70c	1.0396E-11	82206.70c	1.7896E-10	82207.70c	1.6411E-10	
82208.70c	3.8912E-10	83209.70c	7.3626E-10	90232.70c	6.6310E-11	
92234.70c	5.6884E-14	92235.70c	7.4467E-12	92238.70c	1.0268E-09	
c	Total	6.4196E-02				
c						
c	----- Zr Rod -----					
m13	3006.70c	1.0717E-10	3007.70c	1.3049E-09	4009.70c	1.0875E-09
	5010.70c	3.6082E-09	5011.70c	1.4523E-08	9019.70c	1.0318E-07
	11023.70c	8.5264E-10	12024.70c	3.1853E-10	12025.70c	4.0325E-11
	12026.70c	4.4398E-11	13027.70c	5.8120E-06	14028.70c	9.1406E-07
	14029.70c	4.6414E-08	14030.70c	3.0596E-08	15031.70c	9.9991E-08
	16032.70c	2.9012E-08	16033.70c	2.3226E-10	16034.70c	1.3111E-09
	16036.70c	6.1122E-12	17035.70c	1.9273E-08	17037.70c	6.1600E-09
	19039.70c	4.6755E-09	19040.70c	5.8658E-13	19041.70c	3.3742E-10
	20040.70c	2.3707E-09	20042.70c	1.5822E-11	20043.70c	3.3014E-12
	20044.70c	5.1013E-11	20046.70c	9.7819E-14	20048.70c	4.5730E-12
	21045.70c	2.1801E-07	22046.70c	1.1484E-08	22047.70c	1.0356E-08
	22048.70c	1.0261E-07	22049.70c	7.5305E-09	22050.70c	7.2103E-09
	23000.70c	3.3092E-08	24050.70c	3.9312E-07	24052.70c	7.5810E-06
	24053.70c	8.5963E-07	24054.70c	2.1398E-07	25055.70c	9.9904E-07
	26054.70c	6.1547E-06	26056.70c	9.6615E-05	26057.70c	2.2313E-06
	26058.70c	2.9694E-07	27059.70c	7.3175E-08	28058.70c	2.8649E-06
	28060.70c	1.1035E-06	28061.70c	4.7970E-08	28062.70c	1.5295E-07
	28064.70c	3.8952E-08	29063.70c	5.5476E-07	29065.70c	2.4726E-07
	30000.70c	2.4581E-08	31069.70c	7.4355E-08	31071.70c	4.9347E-08
	32070.70c	2.8130E-10	32072.70c	3.7174E-10	32073.70c	1.0434E-10
	32074.70c	4.8971E-10	32076.70c	1.0272E-10	33075.70c	2.0931E-09
	34074.70c	1.1047E-11	34076.70c	1.1631E-10	34077.70c	9.4708E-11
	34078.70c	2.9505E-10	34080.70c	6.1579E-10	34082.70c	1.0836E-10
	35079.70c	6.2176E-10	35081.70c	6.0483E-10	37085.70c	8.2761E-10
	37087.70c	3.1914E-10	38084.70c	6.2640E-12	38086.70c	1.1029E-10
	38087.70c	7.8300E-11	38088.70c	9.2372E-10	39089.70c	1.1024E-09
	40090.70c	2.2070E-02	40091.70c	4.8130E-03	40092.70c	7.3568E-03
	40094.70c	7.4555E-03	40096.70c	1.2011E-03	41093.70c	2.5740E-08
	42092.70c	1.3341E-08	42094.70c	8.3156E-09	42095.70c	1.4312E-08
	42096.70c	1.4995E-08	42097.70c	8.5853E-09	42098.70c	2.1692E-08
	42100.70c	8.6572E-09	44096.70c	5.3723E-11	44098.70c	1.8134E-11
	44099.70c	1.2374E-10	44100.70c	1.2218E-10	44101.70c	1.6543E-10
	44102.70c	3.0595E-10	44104.70c	1.8056E-10	45103.70c	9.5242E-10
	46102.70c	9.3939E-11	46104.70c	1.0260E-09	46105.70c	2.0565E-09
	46106.70c	2.5170E-09	46108.70c	2.4369E-09	46110.70c	1.0794E-09
	47107.70c	4.7101E-09	47109.70c	4.3759E-09	48106.70c	1.0899E-10
	48108.70c	7.7599E-11	48110.70c	1.0890E-09	48111.70c	1.1160E-09
	48112.70c	2.1039E-09	48113.70c	1.0655E-09	48114.70c	2.5050E-09
	48116.70c	6.5305E-10	49113.70c	7.3238E-11	49115.70c	1.6339E-09
	50112.70c	1.5697E-10	50114.70c	1.0680E-10	50115.70c	5.5020E-11
	50116.70c	2.3529E-09	50117.70c	1.2428E-09	50118.70c	3.9193E-09
	50119.70c	1.3901E-09	50120.70c	5.2722E-09	50122.70c	7.4924E-10
	50124.70c	9.3695E-10	51121.70c	4.6054E-10	51123.70c	3.4446E-10
	52120.70c	6.9129E-13	52122.70c	1.9587E-11	52123.70c	6.8361E-12
	52124.70c	3.6408E-11	52125.70c	5.4305E-11	52126.70c	1.4471E-10
	52128.70c	2.4380E-10	52130.70c	2.6177E-10	53127.70c	1.5446E-09
	55133.70c	7.3744E-11	56130.70c	7.5652E-14	56132.70c	7.2083E-14
	56134.70c	1.7250E-12	56135.70c	4.7047E-12	56136.70c	5.6054E-12
	56137.70c	8.0162E-12	56138.70c	5.1171E-11	57138.70c	6.3503E-14
	57139.70c	7.0495E-11	58136.70c	1.2941E-13	58138.70c	1.7557E-13
	58140.70c	6.1870E-11	58142.70c	7.7742E-12	59141.70c	6.9556E-11
	60142.70c	1.8482E-11	60143.70c	8.2898E-12	60144.70c	1.6172E-11
	60145.70c	5.6398E-12	60146.70c	1.1687E-11	60148.70c	3.8731E-12
	60150.70c	3.8051E-12	62144.70c	2.0011E-12	62147.70c	9.7710E-12

Fundamental - FUND

NRAD-FUND-RESR-001
CRIT-REAC-COEF

62148.70c	7.3266E-12	62149.70c	9.0083E-12	62150.70c	4.8105E-12	
62152.70c	1.7437E-11	62154.70c	1.4829E-11	63151.70c	3.0836E-11	
63153.70c	3.3661E-11	64152.70c	1.2465E-13	64154.70c	1.3587E-12	
64155.70c	9.2244E-12	64156.70c	1.2758E-11	64157.70c	9.7542E-12	
64158.70c	1.5482E-11	64160.70c	1.3625E-11	65159.70c	6.1670E-11	
66156.70c	3.6188E-14	66158.70c	6.0314E-14	66160.70c	1.4113E-12	
66161.70c	1.1405E-11	66162.70c	1.5386E-11	66163.70c	1.5018E-11	
66164.70c	1.6996E-11	67165.70c	5.9425E-11	68162.70c	8.2036E-14	
68164.70c	9.4341E-13	68166.70c	1.9695E-11	68167.70c	1.3436E-11	
68168.70c	1.5692E-11	68170.70c	8.7486E-12	69169.55c	5.8016E-11	
5010.70c	7.6464E-15	71175.70c	5.4565E-11	71176.70c	1.4508E-12	
72174.70c	1.9328E-09	72176.70c	6.3542E-08	72177.70c	2.2469E-07	
72178.70c	3.2955E-07	72179.70c	1.6453E-07	72180.70c	4.2378E-07	
73181.70c	5.4165E-08	74182.70c	6.7810E-10	74183.70c	3.6617E-10	
74184.70c	7.8403E-10	74186.70c	7.3055E-10	75185.70c	1.9685E-11	
75187.70c	3.2949E-11	76000.31c	5.1530E-11	77191.70c	1.9019E-11	
77193.70c	3.1970E-11	78000.31c	5.0241E-11	79197.70c	4.9760E-10	
80196.70c	7.3291E-13	80198.70c	4.8714E-11	80199.70c	8.2428E-11	
80200.70c	1.1287E-10	80201.70c	6.4398E-11	80202.70c	1.4590E-10	
80204.70c	3.3567E-11	81000.31c	9.5908E-11	82204.70c	9.5361E-11	
82206.70c	1.6416E-09	82207.70c	1.5053E-09	82208.70c	3.5692E-09	
83209.70c	3.0015E-09	90232.70c	8.4477E-12	92234.70c	6.3410E-14	
92235.70c	8.3010E-12	92238.70c	1.1446E-09			
c	Total	4.3026E-02				
c						
c	----- SS 304 Cladding and End Fittings -----					
m14	3006.70c	2.6341E-10	3007.70c	3.2070E-09	4009.70c	2.6729E-09
	5010.70c	2.2170E-07	5011.70c	8.9237E-07	6000.70c	1.6044E-04
	9019.70c	1.2679E-09	11023.70c	1.0478E-09	12024.70c	2.8183E-07
	12025.70c	3.5679E-08	12026.70c	3.9283E-08	13027.70c	2.1427E-06
	14028.70c	6.3283E-04	14029.70c	3.2134E-05	14030.70c	2.1183E-05
	15031.70c	4.0441E-05	16032.70c	3.1374E-06	16033.70c	2.5117E-08
	16034.70c	1.4178E-07	16036.70c	6.6099E-10	17035.70c	2.5744E-09
	17037.70c	8.2281E-10	19039.70c	5.7456E-10	19040.70c	7.2084E-14
	19041.70c	4.1465E-11	20040.70c	5.8265E-08	20042.70c	3.8887E-10
	20043.70c	8.1140E-11	20044.70c	1.2538E-09	20046.70c	2.4042E-12
	20048.70c	1.1239E-10	21045.70c	2.6791E-10	22046.70c	1.6602E-07
	22047.70c	1.4972E-07	22048.70c	1.4835E-06	22049.70c	1.0887E-07
	22050.70c	1.0424E-07	23000.70c	9.4573E-05	24050.70c	7.6491E-04
	24052.70c	1.4751E-02	24053.70c	1.6726E-03	24054.70c	4.1634E-04
	25055.70c	8.7693E-04	26054.70c	3.4644E-03	26056.70c	5.4383E-02
	26057.70c	1.2559E-03	26058.70c	1.6714E-04	27059.70c	6.5399E-05
	28058.70c	5.5882E-03	28060.70c	2.1526E-03	28061.70c	9.3571E-05
	28062.70c	2.9834E-04	28064.70c	7.5980E-05	29063.70c	1.5732E-04
	29065.70c	7.0120E-05	30000.70c	3.6838E-08	31069.70c	6.6453E-07
	31071.70c	4.4103E-07	32070.70c	2.7655E-07	32072.70c	3.6546E-07
	32073.70c	1.0258E-07	32074.70c	4.8144E-07	32076.70c	1.0098E-07
	33075.70c	2.2506E-06	34074.70c	2.7151E-11	34076.70c	2.8585E-10
	34077.70c	2.3277E-10	34078.70c	7.2515E-10	34080.70c	1.5135E-09
	34082.70c	2.6633E-10	35079.70c	1.5281E-09	35081.70c	1.4865E-09
	37085.70c	1.0170E-08	37087.70c	3.9218E-09	38084.70c	3.0791E-11
	38086.70c	5.4214E-10	38087.70c	3.8489E-10	38088.70c	4.5406E-09
	39089.70c	1.3547E-09	40090.70c	4.8909E-08	40091.70c	1.0666E-08
	40092.70c	1.6303E-08	40094.70c	1.6522E-08	40096.70c	2.6617E-09
	41093.70c	5.7041E-06	42092.70c	2.2356E-05	42094.70c	1.3935E-05
	42095.70c	2.3983E-05	42096.70c	2.5128E-05	42097.70c	1.4387E-05
	42098.70c	3.6351E-05	42100.70c	1.4507E-05	44096.70c	1.3204E-10
	44098.70c	4.4568E-11	44099.70c	3.0411E-10	44100.70c	3.0030E-10
	44101.70c	4.0660E-10	44102.70c	7.5194E-10	44104.70c	4.4378E-10
	45103.70c	1.1704E-09	46102.70c	1.1544E-11	46104.70c	1.2608E-10
	46105.70c	2.5272E-10	46106.70c	3.0931E-10	46108.70c	2.9946E-10
	46110.70c	1.3264E-10	47107.70c	5.7882E-09	47109.70c	5.3775E-09
	48106.70c	2.6786E-11	48108.70c	1.9072E-11	48110.70c	2.6765E-10
	48111.70c	2.7429E-10	48112.70c	5.1708E-10	48113.70c	2.6186E-10
	48114.70c	6.1566E-10	48116.70c	1.6050E-10	49113.70c	4.5001E-10
	49115.70c	1.0040E-08	50112.70c	2.1651E-08	50114.70c	1.4732E-08
	50115.70c	7.5891E-09	50116.70c	3.2455E-07	50117.70c	1.7143E-07
	50118.70c	5.4061E-07	50119.70c	1.9174E-07	50120.70c	7.2722E-07
	50122.70c	1.0335E-07	50124.70c	1.2924E-07	51121.70c	2.0148E-07
	51123.70c	1.5070E-07	52120.70c	8.4951E-13	52122.70c	2.4070E-11
	52123.70c	8.4007E-12	52124.70c	4.4741E-11	52125.70c	6.6734E-11
	52126.70c	1.7783E-10	52128.70c	2.9959E-10	52130.70c	3.2168E-10
	53127.70c	9.4908E-10	55133.70c	1.8124E-10	56130.70c	9.2967E-13
	56132.70c	8.8582E-13	56134.70c	2.1198E-11	56135.70c	5.7815E-11
	56136.70c	6.8883E-11	56137.70c	9.8510E-11	56138.70c	6.2882E-10
	57138.70c	1.5607E-13	57139.70c	1.7326E-10	58136.70c	1.5902E-12

Fundamental - FUND

NRAD-FUND-RESR-001
CRIT-REAC-COEF

58138.70c	2.1576E-12	58140.70c	7.6031E-10	58142.70c	9.5535E-11	
59141.70c	8.5476E-11	60142.70c	2.2712E-11	60143.70c	1.0187E-11	
60144.70c	1.9873E-11	60145.70c	6.9306E-12	60146.70c	1.4362E-11	
60148.70c	4.7596E-12	60150.70c	4.6761E-12	62144.70c	2.4591E-12	
62147.70c	1.2007E-11	62148.70c	9.0035E-12	62149.70c	1.1070E-11	
62150.70c	5.9116E-12	62152.70c	2.1427E-11	62154.70c	1.8223E-11	
63151.70c	3.7894E-11	63153.70c	4.1365E-11	64152.70c	1.5319E-13	
64154.70c	1.6697E-12	64155.70c	1.1336E-11	64156.70c	1.5679E-11	
64157.70c	1.1987E-11	64158.70c	1.9026E-11	64160.70c	1.6743E-11	
65159.70c	7.5785E-11	66156.70c	4.4471E-14	66158.70c	7.4118E-14	
66160.70c	1.7344E-12	66161.70c	1.4016E-11	66162.70c	1.8908E-11	
66163.70c	1.8455E-11	66164.70c	2.0886E-11	67165.70c	7.3026E-11	
68162.70c	1.0081E-13	68164.70c	1.1593E-12	68166.70c	2.4202E-11	
68167.70c	1.6512E-11	68168.70c	1.9284E-11	68170.70c	1.0751E-11	
69169.55c	7.1295E-11	5010.70c	9.3965E-15	71175.70c	6.7054E-11	
71176.70c	1.7829E-12	72174.70c	2.1593E-13	72176.70c	7.0987E-12	
72177.70c	2.5102E-11	72178.70c	3.6816E-11	72179.70c	1.8381E-11	
72180.70c	4.7343E-11	73181.70c	1.3312E-08	74182.70c	1.1111E-06	
74183.70c	5.9998E-07	74184.70c	1.2846E-06	74186.70c	1.1970E-06	
75185.70c	2.4191E-09	75187.70c	4.0491E-09	76000.31c	2.2797E-09	
77191.70c	8.4138E-10	77193.70c	1.4143E-09	78000.31c	1.2348E-09	
79197.70c	6.1148E-10	80196.70c	1.8013E-12	80198.70c	1.1973E-10	
80199.70c	2.0259E-10	80200.70c	2.7740E-10	80201.70c	1.5828E-10	
80202.70c	3.5858E-10	80204.70c	8.2500E-11	81000.31c	5.8929E-10	
82204.70c	1.0091E-10	82206.70c	1.7371E-09	82207.70c	1.5930E-09	
82208.70c	3.7769E-09	83209.70c	1.1527E-10	90232.70c	5.1906E-11	
92234.70c	2.7830E-15	92235.70c	3.6432E-13	92238.70c	5.0233E-11	
c	Total	8.7412E-02				
mt14	fe56.12t					
c						
c	--- Control Rods -----					
c	----- B4C Absorber -----					
m21	5010.70c	2.1515E-02	5011.70c	8.6601E-02	6000.70c	2.7029E-02
c	Total	1.3514E-01				
mt21	grph.10t					
c						
c	----- Al 6061 Cladding and End Fittings -----					
m22	13027.70c	5.8593E-02	24050.70c	2.6495E-06	24052.70c	5.1093E-05
	24053.70c	5.7936E-06	24054.70c	1.4421E-06	29063.70c	4.8671E-05
	29065.70c	2.1694E-05	12024.70c	5.2843E-04	12025.70c	6.6898E-05
	12026.70c	7.3655E-05	25055.70c	2.2197E-05	14028.70c	3.2037E-04
	14029.70c	1.6268E-05	14030.70c	1.0724E-05	26054.70c	5.9561E-06
	26056.70c	9.3499E-05	26057.70c	2.1593E-06	26058.70c	2.8736E-07
	30000.70c	3.1082E-05	22046.70c	2.1012E-06	22047.70c	1.8949E-06
	22048.70c	1.8776E-05	22049.70c	1.3779E-06	22050.70c	1.3193E-06
	27059.70c	6.8975E-06	28058.70c	4.7151E-06	28060.70c	1.8162E-06
	28061.70c	7.8950E-08	28062.70c	2.5173E-07	28064.70c	6.4108E-08
	50112.70c	3.3215E-08	50114.70c	2.2600E-08	50115.70c	1.1642E-08
	50116.70c	4.9788E-07	50117.70c	2.6298E-07	50118.70c	8.2935E-07
	50119.70c	2.9414E-07	50120.70c	1.1156E-06	50122.70c	1.5854E-07
	50124.70c	1.9826E-07				
c	Total	5.9939E-02				
mt22	al27.12t					
c						
c	----- Homogenized Guide Tube Adapter Fitting -----					
c	28.09% SS 304 + 71.91% Al 6061					
m23	13027.70c	4.2136E-02	6000.70c	4.5065E-05	27059.70c	4.9601E-06
	24050.70c	2.1675E-04	24052.70c	4.1798E-03	24053.70c	4.7396E-04
	24054.70c	1.1798E-04	29063.70c	3.5001E-05	29065.70c	1.5600E-05
	26054.70c	9.8748E-04	26056.70c	1.5501E-02	26057.70c	3.5799E-04
	26058.70c	4.7642E-05	12024.70c	3.8001E-04	12025.70c	4.8108E-05
	12026.70c	5.2967E-05	25055.70c	2.6227E-04	28058.70c	1.5730E-03
	28060.70c	6.0592E-04	28061.70c	2.6339E-05	28062.70c	8.3979E-05
	28064.70c	2.1387E-05	15031.70c	9.8298E-06	16032.70c	6.0083E-06
	16033.70c	4.8102E-08	16034.70c	2.7152E-07	16036.70c	1.2658E-09
	14028.70c	4.5257E-04	14029.70c	2.2980E-05	14030.70c	1.5149E-05
	50112.70c	2.3886E-08	50114.70c	1.6252E-08	50115.70c	8.3723E-09
	50116.70c	3.5804E-07	50117.70c	1.8912E-07	50118.70c	5.9641E-07
	50119.70c	2.1152E-07	50120.70c	8.0227E-07	50122.70c	1.1401E-07
	50124.70c	1.4258E-07	22046.70c	1.5110E-06	22047.70c	1.3627E-06
	22048.70c	1.3502E-05	22049.70c	9.9088E-07	22050.70c	9.4875E-07
	30000.70c	2.2352E-05				
c	Total	6.7723E-02				
mt23	al27.12t	fe56.12t				
c						
c	----- Homogenized Control Rod/Extension Rod Interface -----					

Fundamental - FUND

NRAD-FUND-RESR-001
CRIT-REAC-COEF

c 21.91% Water + 78.09% Al 6061
m24 1001.70c 1.4602E-02 1002.70c 1.6794E-06 8016.70c 7.2989E-03
8017.70c 2.7746E-06 13027.70c 4.5753E-02 27059.70c 5.3860E-06
24050.70c 2.0689E-06 24052.70c 3.9897E-05 24053.70c 4.5240E-06
24054.70c 1.1261E-06 29063.70c 3.8006E-05 29065.70c 1.6940E-05
26054.70c 4.6509E-06 26056.70c 7.3010E-05 26057.70c 1.6861E-06
26058.70c 2.2439E-07 12024.70c 4.1263E-04 12025.70c 5.2239E-05
12026.70c 5.7515E-05 25055.70c 1.7333E-05 28058.70c 3.6818E-06
28060.70c 1.4182E-06 28061.70c 6.1650E-08 28062.70c 1.9657E-07
28064.70c 5.0059E-08 14028.70c 2.5017E-04 14029.70c 1.2703E-05
14030.70c 8.3738E-06 50112.70c 2.5937E-08 50114.70c 1.7648E-08
50115.70c 9.0912E-09 50116.70c 3.8878E-07 50117.70c 2.0535E-07
50118.70c 6.4761E-07 50119.70c 2.2969E-07 50120.70c 8.7115E-07
50122.70c 1.2380E-07 50124.70c 1.5482E-07 22046.70c 1.6408E-06
22047.70c 1.4797E-06 22048.70c 1.4662E-05 22049.70c 1.0759E-06
22050.70c 1.0302E-06 30000.70c 2.4271E-05

c Total 6.8709E-02
mt24 lwtr.10t hwtr.10t al27.12t

c
c ----- Homogenized Guide Tube -----
c 3.53% Water + 96.47% Al 6061

m25 1001.70c 2.3519E-03 1002.70c 2.7050E-07 8016.70c 1.1756E-03
8017.70c 4.4691E-07 13027.70c 5.6525E-02 27059.70c 6.6540E-06
24050.70c 2.5560E-06 24052.70c 4.9290E-05 24053.70c 5.5891E-06
24054.70c 1.3912E-06 29063.70c 4.6954E-05 29065.70c 2.0928E-05
26054.70c 5.7459E-06 26056.70c 9.0198E-05 26057.70c 2.0831E-06
26058.70c 2.7722E-07 12024.70c 5.0978E-04 12025.70c 6.4537E-05
12026.70c 7.1055E-05 25055.70c 2.1414E-05 28058.70c 4.5486E-06
28060.70c 1.7521E-06 28061.70c 7.6164E-08 28062.70c 2.4284E-07
28064.70c 6.1845E-08 14028.70c 3.0906E-04 14029.70c 1.5693E-05
14030.70c 1.0345E-05 50112.70c 3.2043E-08 50114.70c 2.1802E-08
50115.70c 1.1231E-08 50116.70c 4.8031E-07 50117.70c 2.5370E-07
50118.70c 8.0008E-07 50119.70c 2.8376E-07 50120.70c 1.0762E-06
50122.70c 1.5295E-07 50124.70c 1.9127E-07 22046.70c 2.0271E-06
22047.70c 1.8280E-06 22048.70c 1.8113E-05 22049.70c 1.3293E-06
22050.70c 1.2727E-06 30000.70c 2.9985E-05

c Total 6.1351E-02
mt25 lwtr.10t hwtr.10t al27.12t

c --- Fuel Cluster Assemblies -----
c ----- Homogenized 4-Fuel-Rod Top Fittings -----

c 77.63% Water + 7.44% SS 304 + 14.93% Al 6061
m31 1001.70c 5.1728E-02 1002.70c 5.9494E-06 8016.70c 2.5857E-02
8017.70c 9.8294E-06 13027.70c 8.7492E-03 6000.70c 1.1932E-05
27059.70c 1.0299E-06 24050.70c 5.7281E-05 24052.70c 1.1046E-03
24053.70c 1.2525E-04 24054.70c 3.1178E-05 29063.70c 7.2677E-06
29065.70c 3.2393E-06 26054.70c 2.6121E-04 26056.70c 4.1005E-03
26057.70c 9.4698E-05 26058.70c 1.2603E-05 12024.70c 7.8906E-05
12025.70c 9.9894E-06 12026.70c 1.0998E-05 25055.70c 6.8531E-05
28058.70c 4.1629E-04 28060.70c 1.6036E-04 28061.70c 6.9706E-06
28062.70c 2.2225E-05 28064.70c 5.6601E-06 15031.70c 2.6027E-06
16032.70c 1.5908E-06 16033.70c 1.2736E-08 16034.70c 7.1892E-08
16036.70c 3.3516E-10 14028.70c 1.0667E-04 14029.70c 5.4163E-06
14030.70c 3.5705E-06 50112.70c 4.9597E-09 50114.70c 3.3747E-09
50115.70c 1.7385E-09 50116.70c 7.4345E-08 50117.70c 3.9269E-08
50118.70c 1.2384E-07 50119.70c 4.3922E-08 50120.70c 1.6659E-07
50122.70c 2.3674E-08 50124.70c 2.9605E-08 22046.70c 3.1376E-07
22047.70c 2.8295E-07 22048.70c 2.8037E-06 22049.70c 2.0575E-07
22050.70c 1.9700E-07 30000.70c 4.6412E-06

c Total 9.3070E-02
mt31 lwtr.10t hwtr.10t fe56.12t al27.12t

c ----- Homogenized 3-Fuel-Rod Top Fittings -----
c 74.79% Water + 7.10% SS 304 + 18.11% Al 6061

m32 1001.70c 4.9835E-02 1002.70c 5.7317E-06 8016.70c 2.4911E-02
8017.70c 9.4697E-06 13027.70c 1.0611E-02 6000.70c 1.1391E-05
27059.70c 1.2491E-06 24050.70c 5.4789E-05 24052.70c 1.0565E-03
24053.70c 1.1980E-04 24054.70c 2.9822E-05 29063.70c 8.8144E-06
29065.70c 3.9287E-06 26054.70c 2.4961E-04 26056.70c 3.9184E-03
26057.70c 9.0492E-05 26058.70c 1.2043E-05 12024.70c 9.5699E-05
12025.70c 1.2115E-05 12026.70c 1.3339E-05 25055.70c 6.6282E-05
28058.70c 3.9762E-04 28060.70c 1.5316E-04 28061.70c 6.6578E-06
28062.70c 2.1228E-05 28064.70c 5.4062E-06 15031.70c 2.4848E-06
16032.70c 1.5188E-06 16033.70c 1.2159E-08 16034.70c 6.8635E-08
16036.70c 3.1998E-10 14028.70c 1.1418E-04 14029.70c 5.7979E-06
14030.70c 3.8220E-06 50112.70c 6.0153E-09 50114.70c 4.0929E-09

Fundamental - FUND

NRAD-FUND-RESR-001
CRIT-REAC-COEF

50115.70c	2.1085E-09	50116.70c	9.0167E-08	50117.70c	4.7626E-08
50118.70c	1.5020E-07	50119.70c	5.3269E-08	50120.70c	2.0204E-07
50122.70c	2.8712E-08	50124.70c	3.5906E-08	22046.70c	3.8053E-07
22047.70c	3.4317E-07	22048.70c	3.4004E-06	22049.70c	2.4954E-07
22050.70c	2.3893E-07	30000.70c	5.6290E-06		
c	Total	9.1839E-02			
mt32	lwtr.10t	hwtr.10t	fe56.12t	al27.12t	
c					
c	----- Homogenized 3- & 4-Fuel-Rod Bottom Fittings -----				
c	34.78% Water + 13.86% SS 304 + 51.36% Al 6061				
m33	1001.70c	2.3172E-02	1002.70c	2.6651E-06	8016.70c 1.1583E-02
	8017.70c	4.4032E-06	13027.70c	3.0094E-02	6000.70c 2.2242E-05
	27059.70c	3.5427E-06	24050.70c	1.0740E-04	24052.70c 2.0711E-03
	24053.70c	2.3484E-04	24054.70c	5.8457E-05	29063.70c 2.4999E-05
	29065.70c	1.1142E-05	26054.70c	4.8832E-04	26056.70c 7.6655E-03
	26057.70c	1.7703E-04	26058.70c	2.3559E-05	12024.70c 2.7141E-04
	12025.70c	3.4360E-05	12026.70c	3.7831E-05	25055.70c 1.3297E-04
	28058.70c	7.7710E-04	28060.70c	2.9934E-04	28061.70c 1.3012E-05
	28062.70c	4.1488E-05	28064.70c	1.0566E-05	15031.70c 4.8515E-06
	16032.70c	2.9654E-06	16033.70c	2.3741E-08	16034.70c 1.3401E-07
	16036.70c	6.2475E-10	14028.70c	2.7421E-04	14029.70c 1.3924E-05
	14030.70c	9.1785E-06	50112.70c	1.7060E-08	50114.70c 1.1608E-08
	50115.70c	5.9798E-09	50116.70c	2.5572E-07	50117.70c 1.3507E-07
	50118.70c	4.2597E-07	50119.70c	1.5108E-07	50120.70c 5.7300E-07
	50122.70c	8.1430E-08	50124.70c	1.0183E-07	22046.70c 1.0792E-06
	22047.70c	9.7327E-07	22048.70c	9.6437E-06	22049.70c 7.0771E-07
	22050.70c	6.7762E-07	30000.70c	1.5964E-05	
c	Total	7.7699E-02			
mt33	lwtr.10t	hwtr.10t	fe56.12t	al27.12t	
c					
c	--- Graphite Reflector Assemblies -----				
c	----- Graphite Reflectors -----				
m41	3006.70c	2.5847E-10	3007.70c	3.1469E-09	4009.70c 2.6227E-09
	5010.70c	1.3053E-08	5011.70c	5.2538E-08	6000.70c 7.8692E-02
	9019.70c	2.4883E-09	11023.70c	6.1688E-09	12024.70c 4.3018E-08
	12025.70c	5.4460E-09	12026.70c	5.9961E-09	13027.70c 4.5554E-08
	14028.70c	2.5149E-06	14029.70c	1.2770E-07	14030.70c 8.4181E-08
	15031.70c	5.4945E-08	16032.70c	1.3993E-06	16033.70c 1.1203E-08
	16034.70c	6.3238E-08	16036.70c	2.9481E-10	17035.70c 4.6481E-08
	17037.70c	1.4856E-08	19039.70c	1.1276E-09	19040.70c 1.4146E-13
	19041.70c	8.1374E-11	20040.70c	5.2599E-07	20042.70c 3.5105E-09
	20043.70c	7.3249E-10	20044.70c	1.1318E-08	20046.70c 2.1703E-11
	20048.70c	1.0146E-09	21045.70c	1.4722E-09	22046.70c 2.9324E-08
	22047.70c	2.6445E-08	22048.70c	2.6203E-07	22049.70c 1.9229E-08
	22050.70c	1.8412E-08	23000.70c	5.3824E-07	24050.70c 1.9752E-10
	24052.70c	3.8089E-09	24053.70c	4.3190E-10	24054.70c 1.0751E-10
	25055.70c	2.0652E-09	26054.70c	5.4425E-08	26056.70c 8.5435E-07
	26057.70c	1.9731E-08	26058.70c	2.6258E-09	27059.70c 8.0215E-11
	28058.70c	3.8384E-08	28060.70c	1.4785E-08	28061.70c 6.4271E-10
	28062.70c	2.0493E-09	28064.70c	5.2189E-10	29063.70c 2.5729E-10
	29065.70c	1.1468E-10	30000.70c	3.6147E-10	31069.70c 4.0754E-11
	31071.70c	2.7048E-11	32070.70c	6.7840E-11	32072.70c 8.9651E-11
	32073.70c	2.5163E-11	32074.70c	1.1810E-10	32076.70c 2.4773E-11
	33075.70c	3.1549E-10	34074.70c	2.6642E-12	34076.70c 2.8049E-11
	34077.70c	2.2840E-11	34078.70c	7.1156E-11	34080.70c 1.4851E-10
	34082.70c	2.6133E-11	35079.70c	2.9990E-10	35081.70c 2.9173E-10
	37085.70c	1.9959E-10	37087.70c	7.6966E-11	38084.70c 3.0818E-11
	38086.70c	5.4261E-10	38087.70c	3.8522E-10	38088.70c 4.5445E-09
	39089.70c	2.6586E-10	40090.70c	2.3463E-09	40091.70c 5.1166E-10
	40092.70c	7.8209E-10	40094.70c	7.9258E-10	40096.70c 1.2769E-10
	41093.70c	2.5441E-10	42092.70c	3.6561E-11	42094.70c 2.2789E-11
	42095.70c	3.9222E-11	42096.70c	4.1095E-11	42097.70c 2.3528E-11
	42098.70c	5.9449E-11	42100.70c	2.3725E-11	44096.70c 1.2956E-11
	44098.70c	4.3733E-12	44099.70c	2.9841E-11	44100.70c 2.9467E-11
	44101.70c	3.9897E-11	44102.70c	7.3784E-11	44104.70c 4.3546E-11
	45103.70c	4.5939E-11	46102.70c	2.2655E-12	46104.70c 2.4743E-11
	46105.70c	4.9597E-11	46106.70c	6.0702E-11	46108.70c 5.8770E-11
	46110.70c	2.6031E-11	47107.70c	1.1359E-10	47109.70c 1.0553E-10
	48106.70c	2.6284E-12	48108.70c	1.8714E-12	48110.70c 2.6263E-11
	48111.70c	2.6915E-11	48112.70c	5.0739E-11	48113.70c 2.5695E-11
	48114.70c	6.0411E-11	48116.70c	1.5749E-11	49113.70c 8.8314E-12
	49115.70c	1.9703E-10	50112.70c	1.9314E-12	50114.70c 1.3141E-12
	50115.70c	6.7699E-13	50116.70c	2.8951E-11	50117.70c 1.5292E-11
	50118.70c	4.8225E-11	50119.70c	1.7104E-11	50120.70c 6.4871E-11
	50122.70c	9.2189E-12	50124.70c	1.1529E-11	51121.70c 1.1107E-10
	51123.70c	8.3073E-11	52120.70c	1.6672E-13	52122.70c 4.7236E-12

Fundamental - FUND

NRAD-FUND-RESR-001
CRIT-REAC-COEF

52123.70c	1.6486E-12	52124.70c	8.7804E-12	52125.70c	1.3097E-11	
52126.70c	3.4899E-11	52128.70c	5.8795E-11	52130.70c	6.3130E-11	
53127.70c	3.7251E-11	55133.70c	1.7785E-10	56130.70c	1.8245E-13	
56132.70c	1.7384E-13	56134.70c	4.1601E-12	56135.70c	1.1346E-11	
56136.70c	1.3518E-11	56137.70c	1.9333E-11	56138.70c	1.2341E-10	
57138.70c	1.5315E-13	57139.70c	1.7001E-10	58136.70c	3.1209E-13	
58138.70c	4.2343E-13	58140.70c	1.4921E-10	58142.70c	1.8749E-11	
59141.70c	1.6775E-10	60142.70c	4.4573E-11	60143.70c	1.9992E-11	
60144.70c	3.9001E-11	60145.70c	1.3601E-11	60146.70c	2.8186E-11	
60148.70c	9.3406E-12	60150.70c	9.1768E-12	62144.70c	9.6521E-13	
62147.70c	4.7129E-12	62148.70c	3.5339E-12	62149.70c	4.3450E-12	
62150.70c	2.3203E-12	62152.70c	8.4103E-12	62154.70c	7.1526E-12	
63151.70c	1.4873E-11	63153.70c	1.6236E-11	64152.70c	6.0125E-14	
64154.70c	6.5537E-13	64155.70c	4.4493E-12	64156.70c	6.1538E-12	
64157.70c	4.7048E-12	64158.70c	7.4676E-12	64160.70c	6.5717E-12	
65159.70c	2.9746E-11	66156.70c	1.7455E-14	66158.70c	2.9091E-14	
66160.70c	6.8074E-13	66161.70c	5.5012E-12	66162.70c	7.4212E-12	
66163.70c	7.2438E-12	66164.70c	8.1979E-12	67165.70c	2.8663E-11	
68162.70c	3.9569E-14	68164.70c	4.5504E-13	68166.70c	9.4994E-12	
68167.70c	6.4808E-12	68168.70c	7.5690E-12	68170.70c	4.2197E-12	
69169.55c	2.7983E-11	5010.70c	3.6881E-15	71175.70c	2.6319E-11	
71176.70c	6.9978E-13	72174.70c	4.2376E-14	72176.70c	1.3931E-12	
72177.70c	4.9263E-12	72178.70c	7.2252E-12	72179.70c	3.6073E-12	
72180.70c	9.2910E-12	73181.70c	2.6125E-07	74182.70c	3.4070E-11	
74183.70c	1.8398E-11	74184.70c	3.9392E-11	74186.70c	3.6705E-11	
75185.70c	9.4950E-12	75187.70c	1.5893E-11	76000.31c	2.4855E-11	
77191.70c	9.1733E-12	77193.70c	1.5420E-11	78000.31c	2.4233E-11	
79197.70c	2.4001E-10	80196.70c	3.5351E-13	80198.70c	2.3497E-11	
80199.70c	3.9758E-11	80200.70c	5.4440E-11	80201.70c	3.1062E-11	
80202.70c	7.0372E-11	80204.70c	1.6191E-11	81000.31c	1.1565E-10	
82204.70c	1.5971E-12	82206.70c	2.7493E-11	82207.70c	2.5211E-11	
82208.70c	5.9776E-11	83209.70c	1.1311E-10	90232.70c	1.0187E-10	
92234.70c	5.4616E-15	92235.70c	7.1497E-13	92238.70c	9.8582E-11	
c	Total	7.8699E-02				
mt41	grph.10t					
c						
c	----- Al 2011 Fittings -----					
m42	13027.70c	5.8488E-02	83209.70c	3.2505E-05	29063.70c	1.0167E-03
	29065.70c	4.5315E-04	26054.70c	6.2209E-06	26056.70c	9.7654E-05
	26057.70c	2.2553E-06	26058.70c	3.0013E-07	82204.70c	4.5898E-07
	82206.70c	7.9010E-06	82207.70c	7.2454E-06	82208.70c	1.7179E-05
	14028.70c	1.1154E-04	14029.70c	5.6635E-06	14030.70c	3.7334E-06
	30000.70c	3.8956E-05	27059.70c	7.2041E-06	28058.70c	4.9246E-06
	28060.70c	1.8970E-06	28061.70c	8.2459E-08	28062.70c	2.6292E-07
	28064.70c	6.6957E-08	50112.70c	3.4691E-08	50114.70c	2.3604E-08
	50115.70c	1.2160E-08	50116.70c	5.2001E-07	50117.70c	2.7467E-07
	50118.70c	8.6621E-07	50119.70c	3.0722E-07	50120.70c	1.1652E-06
	50122.70c	1.6559E-07	50124.70c	2.0708E-07		
c	Total	6.0307E-02				
mt42	al27.12t					
c						
c	----- Homogenized Reflector Top Fittings -----					
c	79.64% Water + 2.61% Al 2011 + 17.76% Al 6061					
m43	1001.70c	5.3064E-02	1002.70c	6.1030E-06	8016.70c	2.6525E-02
	8017.70c	1.0083E-05	13027.70c	1.1929E-02	83209.70c	8.4709E-07
	27059.70c	1.4126E-06	24050.70c	4.7051E-07	24052.70c	9.0733E-06
	24053.70c	1.0288E-06	24054.70c	2.5610E-07	29063.70c	3.5138E-05
	29065.70c	1.5662E-05	26054.70c	1.2198E-06	26056.70c	1.9149E-05
	26057.70c	4.4223E-07	26058.70c	5.8852E-08	12024.70c	9.3840E-05
	12025.70c	1.1880E-05	12026.70c	1.3080E-05	25055.70c	3.9419E-06
	28058.70c	9.6565E-07	28060.70c	3.7197E-07	28061.70c	1.6169E-08
	28062.70c	5.1554E-08	28064.70c	1.3129E-08	82204.70c	1.1961E-08
	82206.70c	2.0590E-07	82207.70c	1.8882E-07	82208.70c	4.4769E-07
	14028.70c	5.9799E-05	14029.70c	3.0364E-06	14030.70c	2.0016E-06
	50112.70c	6.8025E-09	50114.70c	4.6285E-09	50115.70c	2.3844E-09
	50116.70c	1.0197E-07	50117.70c	5.3859E-08	50118.70c	1.6985E-07
	50119.70c	6.0241E-08	50120.70c	2.2848E-07	50122.70c	3.2470E-08
	50124.70c	4.0605E-08	22046.70c	3.7314E-07	22047.70c	3.3651E-07
	22048.70c	3.3343E-06	22049.70c	2.4469E-07	22050.70c	2.3429E-07
	30000.70c	6.5349E-06				
c	Total	9.1820E-02				
mt43	lwtr.10t hwtr.10t al27.12t					
c						
c	----- Homogenized Reflector Bottom Fittings -----					
c	41.92% Water + 6.55% Al 2011 + 0.17% SS 304 + 51.36% Al 6061					
m44	1001.70c	2.7935E-02	1002.70c	3.2129E-06	8016.70c	1.3964E-02

Fundamental - FUND

NRAD-FUND-RESR-001
CRIT-REAC-COEF

8017.70c	5.3082E-06	13027.70c	3.3923E-02	83209.70c	2.1277E-06
6000.70c	2.7124E-07	27059.70c	4.0142E-06	24050.70c	2.6540E-06
24052.70c	5.1179E-05	24053.70c	5.8033E-06	24054.70c	1.4446E-06
29063.70c	9.1549E-05	29065.70c	4.0805E-05	26054.70c	9.3842E-06
26056.70c	1.4731E-04	26057.70c	3.4021E-06	26058.70c	4.5275E-07
12024.70c	2.7141E-04	12025.70c	3.4360E-05	12026.70c	3.7831E-05
25055.70c	1.2883E-05	28058.70c	1.2191E-05	28060.70c	4.6961E-06
28061.70c	2.0414E-07	28062.70c	6.5088E-07	28064.70c	1.6576E-07
15031.70c	5.9165E-08	82204.70c	3.0044E-08	82206.70c	5.1719E-07
82207.70c	4.7427E-07	82208.70c	1.1245E-06	16032.70c	3.6163E-08
16033.70c	2.8952E-10	16034.70c	1.6343E-09	16036.70c	7.6190E-12
14028.70c	1.7319E-04	14029.70c	8.7940E-06	14030.70c	5.7971E-06
50112.70c	1.9331E-08	50114.70c	1.3153E-08	50115.70c	6.7757E-09
50116.70c	2.8976E-07	50117.70c	1.5305E-07	50118.70c	4.8267E-07
50119.70c	1.7119E-07	50120.70c	6.4927E-07	50122.70c	9.2269E-08
50124.70c	1.1539E-07	22046.70c	1.0792E-06	22047.70c	9.7327E-07
22048.70c	9.6437E-06	22049.70c	7.0771E-07	22050.70c	6.7762E-07
30000.70c	1.8514E-05				

c Total 7.6788E-02
mt44 lwtr.10t hwtr.10t fe56.12t al27.12t

c
c ----- Smearred AmBe Source -----

m45	95241.70c	4.3062E-04	4009.70c	2.7129E-03	93237.70c	2.9906E-05
	94239.70c	4.9228E-07	94240.70c	1.8486E-07	92235.70c	1.1985E-08
	92238.70c	1.0787E-07	8016.70c	9.2230E-04	8017.70c	3.5061E-07
	21045.70c	3.3943E-06	38084.70c	1.0549E-08	38086.70c	1.8573E-07
	38087.70c	1.3186E-07	38088.70c	1.5555E-06	39089.70c	1.7280E-06
	40090.70c	9.4258E-07	40091.70c	2.0555E-07	40092.70c	3.1419E-07
	40094.70c	3.1841E-07	40096.70c	5.1297E-08	42092.70c	2.9383E-07
	42094.70c	1.8315E-07	42095.70c	3.1522E-07	42096.70c	3.3026E-07
	42097.70c	1.8909E-07	42098.70c	4.7777E-07	42100.70c	1.9067E-07
	56130.70c	1.4663E-09	56132.70c	1.3971E-09	56134.70c	3.3434E-08
	56135.70c	9.1186E-08	56136.70c	1.0864E-07	56137.70c	1.5537E-07
	56138.70c	9.9178E-07	74182.70c	4.6832E-08	74183.70c	2.5289E-08
	74184.70c	5.4148E-08	74186.70c	5.0455E-08		

c Total 4.1093E-03
mt45 be.10t o2/u.10t

c
c ----- SS 304 Source Container -----

m46	26054.70c	3.5004E-03	26056.70c	5.4949E-02	26057.70c	1.2690E-03
	26058.70c	1.6888E-04	24050.70c	7.6491E-04	24052.70c	1.4751E-02
	24053.70c	1.6726E-03	24054.70c	4.1634E-04	28058.70c	5.5882E-03
	28060.70c	2.1526E-03	28061.70c	9.3571E-05	28062.70c	2.9834E-04
	28064.70c	7.5980E-05	25055.70c	8.7693E-04	14028.70c	7.9104E-04
	14029.70c	4.0167E-05	14030.70c	2.6478E-05	6000.70c	1.6044E-04
	15031.70c	3.4997E-05	16032.70c	2.1391E-05	16033.70c	1.7126E-07
	16034.70c	9.6669E-07	16036.70c	4.5067E-09		

c Total 8.7653E-02
mt46 fe56.12t

c
c ----- Homogenized Source Reflector Top Fitting -----

c	77.53% Water + 3.13% Al 2011 + 19.34% Al 6061					
m47	1001.70c	5.1663E-02	1002.70c	5.9419E-06	8016.70c	2.5824E-02
	8017.70c	9.8170E-06	13027.70c	1.3161E-02	83209.70c	1.0176E-06
	27059.70c	1.5593E-06	24050.70c	5.1232E-07	24052.70c	9.8795E-06
	24053.70c	1.1203E-06	24054.70c	2.7886E-07	29063.70c	4.1240E-05
	29065.70c	1.8381E-05	26054.70c	1.3464E-06	26056.70c	2.1136E-05
	26057.70c	4.8813E-07	26058.70c	6.4961E-08	12024.70c	1.0218E-04
	12025.70c	1.2936E-05	12026.70c	1.4242E-05	25055.70c	4.2921E-06
	28058.70c	1.0659E-06	28060.70c	4.1058E-07	28061.70c	1.7848E-08
	28062.70c	5.6906E-08	28064.70c	1.4492E-08	82204.70c	1.4369E-08
	82206.70c	2.4735E-07	82207.70c	2.2682E-07	82208.70c	5.3781E-07
	14028.70c	6.5439E-05	14029.70c	3.3229E-06	14030.70c	2.1905E-06
	50112.70c	7.5086E-09	50114.70c	5.1090E-09	50115.70c	2.6319E-09
	50116.70c	1.1255E-07	50117.70c	5.9450E-08	50118.70c	1.8748E-07
	50119.70c	6.6494E-08	50120.70c	2.5220E-07	50122.70c	3.5840E-08
	50124.70c	4.4820E-08	22046.70c	4.0630E-07	22047.70c	3.6641E-07
	22048.70c	3.6306E-06	22049.70c	2.6643E-07	22050.70c	2.5511E-07
	30000.70c	7.2297E-06				

c Total 9.0981E-02
mt47 lwtr.10t hwtr.10t al27.12t

c
c --- Beam Lines -----

c ----- Homogenized Beam Tube Support -----
c 79.49% Water + 20.51% Al 6061

m51	1001.70c	5.2965E-02	1002.70c	6.0917E-06	8016.70c	2.6476E-02
-----	----------	------------	----------	------------	----------	------------

Fundamental - FUND

NRAD-FUND-RESR-001
CRIT-REAC-COEF

8017.70c	1.0065E-05	13027.70c	1.2019E-02	27059.70c	1.4148E-06	
24050.70c	5.4347E-07	24052.70c	1.0480E-05	24053.70c	1.1884E-06	
24054.70c	2.9581E-07	29063.70c	9.9836E-06	29065.70c	4.4498E-06	
26054.70c	1.2217E-06	26056.70c	1.9179E-05	26057.70c	4.4292E-07	
26058.70c	5.8944E-08	12024.70c	1.0839E-04	12025.70c	1.3722E-05	
12026.70c	1.5108E-05	25055.70c	4.5531E-06	28058.70c	9.6716E-07	
28060.70c	3.7255E-07	28061.70c	1.6194E-08	28062.70c	5.1635E-08	
28064.70c	1.3150E-08	14028.70c	6.5715E-05	14029.70c	3.3368E-06	
14030.70c	2.1997E-06	50112.70c	6.8131E-09	50114.70c	4.6357E-09	
50115.70c	2.3881E-09	50116.70c	1.0213E-07	50117.70c	5.3943E-08	
50118.70c	1.7012E-07	50119.70c	6.0335E-08	50120.70c	2.2884E-07	
50122.70c	3.2520E-08	50124.70c	4.0668E-08	22046.70c	4.3101E-07	
22047.70c	3.8869E-07	22048.70c	3.8514E-06	22049.70c	2.8264E-07	
22050.70c	2.7062E-07	30000.70c	6.3756E-06			
c	Total	9.1752E-02				
mt51	lwtr.10t	hwtr.10t	al27.12t			
c						
c	----- Al 6061 Beam Tubes -----					
m52	13027.70c	5.8593E-02	24050.70c	2.6495E-06	24052.70c	5.1093E-05
	24053.70c	5.7936E-06	24054.70c	1.4421E-06	29063.70c	4.8671E-05
	29065.70c	2.1694E-05	12024.70c	5.2843E-04	12025.70c	6.6898E-05
	12026.70c	7.3655E-05	25055.70c	2.2197E-05	14028.70c	3.2037E-04
	14029.70c	1.6268E-05	14030.70c	1.0724E-05	26054.70c	5.9561E-06
	26056.70c	9.3499E-05	26057.70c	2.1593E-06	26058.70c	2.8736E-07
	30000.70c	3.1082E-05	22046.70c	2.1012E-06	22047.70c	1.8949E-06
	22048.70c	1.8776E-05	22049.70c	1.3779E-06	22050.70c	1.3193E-06
	27059.70c	6.8975E-06	28058.70c	4.7151E-06	28060.70c	1.8162E-06
	28061.70c	7.8950E-08	28062.70c	2.5173E-07	28064.70c	6.4108E-08
	50112.70c	3.3215E-08	50114.70c	2.2600E-08	50115.70c	1.1642E-08
	50116.70c	4.9788E-07	50117.70c	2.6298E-07	50118.70c	8.2935E-07
	50119.70c	2.9414E-07	50120.70c	1.1156E-06	50122.70c	1.5854E-07
	50124.70c	1.9826E-07				
c	Total	5.9939E-02				
mt52	al27.12t					
c						
c	----- Helium -----					
m53	2003.70c	1.6794E-12	2004.70c	1.2258E-06		
c	Total	1.2258E-06				
c						
c	----- Boron Nitride -----					
m54	5010.70c	9.6267E-03	5011.70c	3.8749E-02	7014.70c	4.8197E-02
	7015.70c	1.7802E-04	13027.70c	6.8105E-07	79197.70c	6.3900E-09
	4009.70c	1.3966E-07	20040.70c	1.8899E-05	20042.70c	1.2614E-07
	20043.70c	2.6319E-08	20044.70c	4.0668E-07	20046.70c	7.7983E-10
	20048.70c	3.6457E-08	24050.70c	2.3980E-08	24052.70c	4.6243E-07
	24053.70c	5.2436E-08	24054.70c	1.3052E-08	29063.70c	1.3700E-08
	29065.70c	6.1063E-09	26054.70c	1.3173E-09	26056.70c	2.0679E-08
	26057.70c	4.7756E-10	26058.70c	6.3554E-11	19039.70c	6.9048E-07
	19040.70c	8.6626E-11	19041.70c	4.9830E-08	12024.70c	4.0904E-08
	12025.70c	5.1784E-09	12026.70c	5.7015E-09	25055.70c	3.2074E-08
	42092.70c	1.9468E-09	42094.70c	1.2135E-09	42095.70c	2.0885E-09
	42096.70c	2.1882E-09	42097.70c	1.2528E-09	42098.70c	3.1656E-09
	42100.70c	1.2633E-09	11023.70c	1.0949E-06	28058.70c	1.4599E-08
	28060.70c	5.6236E-09	28061.70c	2.4445E-10	28062.70c	7.7943E-10
	28064.70c	1.9850E-10	82204.70c	8.5042E-11	82206.70c	1.4639E-09
	82207.70c	1.3424E-09	82208.70c	3.1830E-09	14028.70c	9.9634E-05
	14029.70c	5.0592E-06	14030.70c	3.3350E-06	50112.70c	1.0284E-10
	50114.70c	6.9976E-11	50115.70c	3.6048E-11	50116.70c	1.5416E-09
	50117.70c	8.1427E-10	50118.70c	2.5679E-09	50119.70c	9.1075E-10
	50120.70c	3.4543E-09	50122.70c	4.9089E-10	50124.70c	6.1388E-10
	22046.70c	2.1687E-09	22047.70c	1.9557E-09	22048.70c	1.9379E-08
	22049.70c	1.4221E-09	22050.70c	1.3617E-09	23000.70c	2.4707E-08
	74182.70c	1.8142E-09	74183.70c	9.7965E-10	74184.70c	2.0976E-09
	74186.70c	1.9545E-09	30000.70c	1.9248E-08	40090.70c	7.0986E-09
	40091.70c	1.5480E-09	40092.70c	2.3662E-09	40094.70c	2.3979E-09
	40096.70c	3.8632E-10	8016.70c	3.3814E-03	8017.70c	1.2854E-06
c	Total	1.0026E-01				
c						
c	--- Structural Materials ---					
c	----- Homogenized Empty Grid Plate -----					
c	51.85% Water + 48.15% Al 1100					
m61	1001.70c	3.4550E-02	1002.70c	3.9738E-06	8016.70c	1.7271E-02
	8017.70c	6.5653E-06	13027.70c	2.8897E-02	27059.70c	3.3333E-06
	29063.70c	1.0691E-05	29065.70c	4.7653E-06	26054.70c	2.0560E-06
	26056.70c	3.2275E-05	26057.70c	7.4537E-07	26058.70c	9.9194E-08
	25055.70c	3.5757E-06	28058.70c	2.2786E-06	28060.70c	8.7772E-07

Fundamental - FUND

NRAD-FUND-RESR-001
CRIT-REAC-COEF

28061.70c	3.8154E-08	28062.70c	1.2165E-07	28064.70c	3.0981E-08
14028.70c	6.4510E-05	14029.70c	3.2757E-06	14030.70c	2.1593E-06
50112.70c	1.6052E-08	50114.70c	1.0922E-08	50115.70c	5.6264E-09
50116.70c	2.4061E-07	50117.70c	1.2709E-07	50118.70c	4.0080E-07
50119.70c	1.4215E-07	50120.70c	5.3914E-07	50122.70c	7.6618E-08
50124.70c	9.5814E-08	30000.70c	6.0084E-06		
c	Total	8.0867E-02			
mt61	lwtr.10t	hwtr.10t	al27.12t		
c					
c	----- Homogenized Grid Plate with Fuel Assembly Fitting -----				
c	36.52% Water + 48.15% Al 1100 + 0.05% SS 304 + 15.28% Al 6061				
m62	1001.70c	2.4333E-02	1002.70c	2.7987E-06	8016.70c 1.2163E-02
	8017.70c	4.6239E-06	13027.70c	3.7852E-02	6000.70c 8.1372E-08
	27059.70c	4.3874E-06	24050.70c	7.9286E-07	24052.70c 1.5289E-05
	24053.70c	1.7337E-06	24054.70c	4.3156E-07	29063.70c 1.8130E-05
	29065.70c	8.0807E-06	26054.70c	4.7416E-06	26056.70c 7.4433E-05
	26057.70c	1.7190E-06	26058.70c	2.2876E-07	12024.70c 8.0758E-05
	12025.70c	1.0224E-05	12026.70c	1.1256E-05	25055.70c 7.4128E-06
	28058.70c	5.8334E-06	28060.70c	2.2470E-06	28061.70c 9.7676E-08
	28062.70c	3.1144E-07	28064.70c	7.9313E-08	15031.70c 1.7749E-08
	16032.70c	1.0849E-08	16033.70c	8.6856E-11	16034.70c 4.9028E-10
	16036.70c	2.2857E-12	14028.70c	1.1387E-04	14029.70c 5.7822E-06
	14030.70c	3.8116E-06	50112.70c	2.1128E-08	50114.70c 1.4376E-08
	50115.70c	7.4057E-09	50116.70c	3.1670E-07	50117.70c 1.6728E-07
	50118.70c	5.2754E-07	50119.70c	1.8710E-07	50120.70c 7.0964E-07
	50122.70c	1.0085E-07	50124.70c	1.2611E-07	22046.70c 3.2112E-07
	22047.70c	2.8959E-07	22048.70c	2.8695E-06	22049.70c 2.1058E-07
	22050.70c	2.0163E-07	30000.70c	1.0759E-05	
c	Total	7.4744E-02			
mt62	lwtr.10t	hwtr.10t	fe56.12t	al27.12t	
c					
c	----- Homogenized Grid Plate with Reflector Assembly Fitting -----				
c	24.28% Water + 48.15% Al 1100 + 12.24% Al 2011 + 0.05% SS 304 + 15.28% Al 6061				
m63	1001.70c	1.6176E-02	1002.70c	1.8605E-06	8016.70c 8.0859E-03
	8017.70c	3.0738E-06	13027.70c	4.5012E-02	83209.70c 3.9792E-06
	6000.70c	8.1372E-08	27059.70c	5.2694E-06	24050.70c 7.9286E-07
	24052.70c	1.5289E-05	24053.70c	1.7337E-06	24054.70c 4.3156E-07
	29063.70c	1.4259E-04	29065.70c	6.3555E-05	26054.70c 5.5031E-06
	26056.70c	8.6387E-05	26057.70c	1.9951E-06	26058.70c 2.6551E-07
	12024.70c	8.0758E-05	12025.70c	1.0224E-05	12026.70c 1.1256E-05
	25055.70c	7.4128E-06	28058.70c	6.4363E-06	28060.70c 2.4792E-06
	28061.70c	1.0777E-07	28062.70c	3.4362E-07	28064.70c 8.7510E-08
	15031.70c	1.7749E-08	82204.70c	5.6188E-08	82206.70c 9.6724E-07
	82207.70c	8.8697E-07	82208.70c	2.1030E-06	16032.70c 1.0849E-08
	16033.70c	8.6856E-11	16034.70c	4.9028E-10	16036.70c 2.2857E-12
	14028.70c	1.2753E-04	14029.70c	6.4755E-06	14030.70c 4.2687E-06
	50112.70c	2.5375E-08	50114.70c	1.7265E-08	50115.70c 8.8943E-09
	50116.70c	3.8036E-07	50117.70c	2.0091E-07	50118.70c 6.3359E-07
	50119.70c	2.2471E-07	50120.70c	8.5228E-07	50122.70c 1.2112E-07
	50124.70c	1.5146E-07	22046.70c	3.2112E-07	22047.70c 2.8959E-07
	22048.70c	2.8695E-06	22049.70c	2.1058E-07	22050.70c 2.0163E-07
	30000.70c	1.5528E-05			
c	Total	6.9890E-02			
mt63	lwtr.10t	hwtr.10t	fe56.12t	al27.12t	
c					
c	----- Homogenized Grid Plate with Beam Tube Support Fitting -----				
c	38.90% Water + 48.15% Al 1100 + 12.95% Al 6061				
m64	1001.70c	2.5923E-02	1002.70c	2.9815E-06	8016.70c 1.2958E-02
	8017.70c	4.9260E-06	13027.70c	3.6483E-02	27059.70c 4.2264E-06
	24050.70c	3.4304E-07	24052.70c	6.6151E-06	24053.70c 7.5010E-07
	24054.70c	1.8672E-07	29063.70c	1.6993E-05	29065.70c 7.5740E-06
	26054.70c	2.8271E-06	26056.70c	4.4380E-05	26057.70c 1.0249E-06
	26058.70c	1.3640E-07	12024.70c	6.8417E-05	12025.70c 8.6614E-06
	12026.70c	9.5362E-06	25055.70c	6.4496E-06	28058.70c 2.8891E-06
	28060.70c	1.1129E-06	28061.70c	4.8376E-08	28062.70c 1.5424E-07
	28064.70c	3.9281E-08	14028.70c	1.0599E-04	14029.70c 5.3818E-06
	14030.70c	3.5478E-06	50112.70c	2.0352E-08	50114.70c 1.3848E-08
	50115.70c	7.1337E-09	50116.70c	3.0507E-07	50117.70c 1.6114E-07
	50118.70c	5.0817E-07	50119.70c	1.8023E-07	50120.70c 6.8358E-07
	50122.70c	9.7145E-08	50124.70c	1.2148E-07	22046.70c 2.7205E-07
	22047.70c	2.4534E-07	22048.70c	2.4310E-06	22049.70c 1.7840E-07
	22050.70c	1.7081E-07	30000.70c	1.0033E-05	
c	Total	7.5685E-02			
mt64	lwtr.10t	hwtr.10t	al27.12t		
c					
c	----- Homogenized Al 6061 Core Support Structure -----				

Fundamental - FUND

NRAD-FUND-RESR-001
CRIT-REAC-COEF

c	55.28% Water + 44.72% Al 6061					
m65	1001.70c	3.6837E-02	1002.70c	4.2368E-06	8016.70c	1.8414E-02
	8017.70c	6.9999E-06	13027.70c	2.6201E-02	27059.70c	3.0843E-06
	24050.70c	1.1848E-06	24052.70c	2.2847E-05	24053.70c	2.5907E-06
	24054.70c	6.4487E-07	29063.70c	2.1764E-05	29065.70c	9.7006E-06
	26054.70c	2.6634E-06	26056.70c	4.1809E-05	26057.70c	9.6556E-07
	26058.70c	1.2850E-07	12024.70c	2.3630E-04	12025.70c	2.9915E-05
	12026.70c	3.2936E-05	25055.70c	9.9258E-06	28058.70c	2.1084E-06
	28060.70c	8.1216E-07	28061.70c	3.5304E-08	28062.70c	1.1256E-07
	28064.70c	2.8667E-08	14028.70c	1.4326E-04	14029.70c	7.2743E-06
	14030.70c	4.7953E-06	50112.70c	1.4853E-08	50114.70c	1.0106E-08
	50115.70c	5.2061E-09	50116.70c	2.2264E-07	50117.70c	1.1760E-07
	50118.70c	3.7086E-07	50119.70c	1.3153E-07	50120.70c	4.9887E-07
	50122.70c	7.0895E-08	50124.70c	8.8656E-08	22046.70c	9.3959E-07
	22047.70c	8.4734E-07	22048.70c	8.3960E-06	22049.70c	6.1615E-07
	22050.70c	5.8995E-07	30000.70c	1.3899E-05		
c	Total	8.2064E-02				
mt65	lwtr.10t	hwtr.10t	al27.12t			
c	----- Al 6061 Mounting Pad and Tank -----					
m66	13027.70c	5.8593E-02	24050.70c	2.6495E-06	24052.70c	5.1093E-05
	24053.70c	5.7936E-06	24054.70c	1.4421E-06	29063.70c	4.8671E-05
	29065.70c	2.1694E-05	12024.70c	5.2843E-04	12025.70c	6.6898E-05
	12026.70c	7.3655E-05	25055.70c	2.2197E-05	14028.70c	3.2037E-04
	14029.70c	1.6268E-05	14030.70c	1.0724E-05	26054.70c	5.9561E-06
	26056.70c	9.3499E-05	26057.70c	2.1593E-06	26058.70c	2.8736E-07
	30000.70c	3.1082E-05	22046.70c	2.1012E-06	22047.70c	1.8949E-06
	22048.70c	1.8776E-05	22049.70c	1.3779E-06	22050.70c	1.3193E-06
	27059.70c	6.8975E-06	28058.70c	4.7151E-06	28060.70c	1.8162E-06
	28061.70c	7.8950E-08	28062.70c	2.5173E-07	28064.70c	6.4108E-08
	50112.70c	3.3215E-08	50114.70c	2.2600E-08	50115.70c	1.1642E-08
	50116.70c	4.9788E-07	50117.70c	2.6298E-07	50118.70c	8.2935E-07
	50119.70c	2.9414E-07	50120.70c	1.1156E-06	50122.70c	1.5854E-07
	50124.70c	1.9826E-07				
c	Total	5.9939E-02				
mt66	al27.12t					
c	--- UErZrH Fuel -----					
c	----- Fuel Rod : 11752 -----					
m101	92234.70c	9.9035E-06	92235.70c	1.0820E-03	92236.70c	1.2002E-05
	92238.70c	4.3193E-03	5010.70c	7.6187E-08	5011.70c	3.0666E-07
	1001.70c	5.0609E-02	1002.70c	5.8207E-06	6000.70c	1.1128E-03
	40090.70c	1.6481E-02	40091.70c	3.5941E-03	40092.70c	5.4936E-03
	40094.70c	5.5673E-03	40096.70c	8.9692E-04	68162.70c	3.1036E-07
	68164.70c	3.5691E-06	68166.70c	7.4507E-05	68167.70c	5.0832E-05
	68168.70c	5.9367E-05	68170.70c	3.3097E-05	72174.70c	1.3203E-09
	72176.70c	4.3404E-08	72177.70c	1.5348E-07	72178.70c	2.2511E-07
	72179.70c	1.1239E-07	72180.70c	2.8947E-07		
c	Total	8.9406E-02				
mt101	h/zr.10t	zr/h.10t				
c	----- Fuel Rod : 11753 -----					
m102	92234.70c	9.9461E-06	92235.70c	1.0865E-03	92236.70c	1.2053E-05
	92238.70c	4.3380E-03	5010.70c	7.6216E-08	5011.70c	3.0678E-07
	1001.70c	5.0542E-02	1002.70c	5.8130E-06	6000.70c	1.1132E-03
	40090.70c	1.6459E-02	40091.70c	3.5893E-03	40092.70c	5.4864E-03
	40094.70c	5.5600E-03	40096.70c	8.9574E-04	68162.70c	3.1047E-07
	68164.70c	3.5704E-06	68166.70c	7.4535E-05	68167.70c	5.0851E-05
	68168.70c	5.9389E-05	68170.70c	3.3110E-05	72174.70c	1.3185E-09
	72176.70c	4.3347E-08	72177.70c	1.5328E-07	72178.70c	2.2481E-07
	72179.70c	1.1224E-07	72180.70c	2.8909E-07		
c	Total	8.9321E-02				
mt102	h/zr.10t	zr/h.10t				
c	----- Fuel Rod : 11754 -----					
m103	92234.70c	9.9494E-06	92235.70c	1.0868E-03	92236.70c	1.2057E-05
	92238.70c	4.3395E-03	5010.70c	7.6241E-08	5011.70c	3.0688E-07
	1001.70c	5.0559E-02	1002.70c	5.8149E-06	6000.70c	1.1136E-03
	40090.70c	1.6465E-02	40091.70c	3.5905E-03	40092.70c	5.4882E-03
	40094.70c	5.5618E-03	40096.70c	8.9603E-04	68162.70c	3.1057E-07
	68164.70c	3.5716E-06	68166.70c	7.4560E-05	68167.70c	5.0868E-05
	68168.70c	5.9408E-05	68170.70c	3.3121E-05	72174.70c	1.3190E-09
	72176.70c	4.3361E-08	72177.70c	1.5333E-07	72178.70c	2.2488E-07
	72179.70c	1.1228E-07	72180.70c	2.8918E-07		
c	Total	8.9350E-02				
mt103	h/zr.10t	zr/h.10t				

Fundamental - FUND

NRAD-FUND-RESR-001
CRIT-REAC-COEF

```

c
c ----- Fuel Rod : 11755 -----
m104 92234.70c 9.9421E-06 92235.70c 1.0861E-03 92236.70c 1.2048E-05
      92238.70c 4.3363E-03 5010.70c 7.6186E-08 5011.70c 3.0666E-07
      1001.70c 5.0836E-02 1002.70c 5.8469E-06 6000.70c 1.1128E-03
      40090.70c 1.6451E-02 40091.70c 3.5876E-03 40092.70c 5.4837E-03
      40094.70c 5.5572E-03 40096.70c 8.9529E-04 68162.70c 3.1035E-07
      68164.70c 3.5690E-06 68166.70c 7.4506E-05 68167.70c 5.0831E-05
      68168.70c 5.9366E-05 68170.70c 3.3097E-05 72174.70c 1.3179E-09
      72176.70c 4.3325E-08 72177.70c 1.5320E-07 72178.70c 2.2470E-07
      72179.70c 1.1218E-07 72180.70c 2.8894E-07
c      Total 8.9597E-02
mt104 h/zr.10t zr/h.10t
c
c ----- Fuel Rod : 11756 -----
m105 92234.70c 9.9470E-06 92235.70c 1.0865E-03 92236.70c 1.2054E-05
      92238.70c 4.3385E-03 5010.70c 7.6223E-08 5011.70c 3.0681E-07
      1001.70c 5.0547E-02 1002.70c 5.8135E-06 6000.70c 1.1133E-03
      40090.70c 1.6461E-02 40091.70c 3.5897E-03 40092.70c 5.4869E-03
      40094.70c 5.5605E-03 40096.70c 8.9582E-04 68162.70c 3.1050E-07
      68164.70c 3.5708E-06 68166.70c 7.4543E-05 68167.70c 5.0856E-05
      68168.70c 5.9394E-05 68170.70c 3.3113E-05 72174.70c 1.3187E-09
      72176.70c 4.3351E-08 72177.70c 1.5329E-07 72178.70c 2.2483E-07
      72179.70c 1.1225E-07 72180.70c 2.8912E-07
c      Total 8.9329E-02
mt105 h/zr.10t zr/h.10t
c
c ----- Fuel Rod : 11757 -----
m106 92234.70c 9.9425E-06 92235.70c 1.0861E-03 92236.70c 1.2049E-05
      92238.70c 4.3365E-03 5010.70c 7.6189E-08 5011.70c 3.0667E-07
      1001.70c 5.0524E-02 1002.70c 5.8109E-06 6000.70c 1.1128E-03
      40090.70c 1.6453E-02 40091.70c 3.5881E-03 40092.70c 5.4844E-03
      40094.70c 5.5580E-03 40096.70c 8.9542E-04 68162.70c 3.1036E-07
      68164.70c 3.5692E-06 68166.70c 7.4509E-05 68167.70c 5.0833E-05
      68168.70c 5.9368E-05 68170.70c 3.3098E-05 72174.70c 1.3181E-09
      72176.70c 4.3331E-08 72177.70c 1.5322E-07 72178.70c 2.2473E-07
      72179.70c 1.1220E-07 72180.70c 2.8899E-07
c      Total 8.9289E-02
mt106 h/zr.10t zr/h.10t
c
c ----- Fuel Rod : 11758 -----
m107 92234.70c 9.9454E-06 92235.70c 1.0864E-03 92236.70c 1.2052E-05
      92238.70c 4.3377E-03 5010.70c 7.6211E-08 5011.70c 3.0676E-07
      1001.70c 5.0853E-02 1002.70c 5.8488E-06 6000.70c 1.1131E-03
      40090.70c 1.6456E-02 40091.70c 3.5887E-03 40092.70c 5.4854E-03
      40094.70c 5.5590E-03 40096.70c 8.9558E-04 68162.70c 3.1045E-07
      68164.70c 3.5702E-06 68166.70c 7.4531E-05 68167.70c 5.0848E-05
      68168.70c 5.9385E-05 68170.70c 3.3107E-05 72174.70c 1.3183E-09
      72176.70c 4.3339E-08 72177.70c 1.5325E-07 72178.70c 2.2477E-07
      72179.70c 1.1222E-07 72180.70c 2.8904E-07
c      Total 8.9626E-02
mt107 h/zr.10t zr/h.10t
c
c ----- Fuel Rod : 11759 -----
m108 92234.70c 9.9408E-06 92235.70c 1.0859E-03 92236.70c 1.2047E-05
      92238.70c 4.3357E-03 5010.70c 7.6175E-08 5011.70c 3.0662E-07
      1001.70c 5.1143E-02 1002.70c 5.8822E-06 6000.70c 1.1126E-03
      40090.70c 1.6447E-02 40091.70c 3.5867E-03 40092.70c 5.4823E-03
      40094.70c 5.5558E-03 40096.70c 8.9507E-04 68162.70c 3.1031E-07
      68164.70c 3.5685E-06 68166.70c 7.4496E-05 68167.70c 5.0824E-05
      68168.70c 5.9357E-05 68170.70c 3.3092E-05 72174.70c 1.3175E-09
      72176.70c 4.3314E-08 72177.70c 1.5316E-07 72178.70c 2.2464E-07
      72179.70c 1.1216E-07 72180.70c 2.8887E-07
c      Total 8.9895E-02
mt108 h/zr.10t zr/h.10t
c
c ----- Fuel Rod : 11760 -----
m109 92234.70c 9.9557E-06 92235.70c 1.0874E-03 92236.70c 1.2065E-05
      92238.70c 4.3423E-03 5010.70c 7.6333E-08 5011.70c 3.0725E-07
      1001.70c 5.0265E-02 1002.70c 5.7812E-06 6000.70c 1.1868E-03
      40090.70c 1.6473E-02 40091.70c 3.5924E-03 40092.70c 5.4911E-03
      40094.70c 5.5648E-03 40096.70c 8.9651E-04 68162.70c 3.2902E-07
      68164.70c 3.7838E-06 68166.70c 7.8989E-05 68167.70c 5.3890E-05
      68168.70c 6.2938E-05 68170.70c 3.5088E-05 72174.70c 1.3197E-09
      72176.70c 4.3384E-08 72177.70c 1.5341E-07 72178.70c 2.2500E-07
      72179.70c 1.1234E-07 72180.70c 2.8934E-07

```

Fundamental - FUND

NRAD-FUND-RESR-001
CRIT-REAC-COEF

c	Total 8.9164E-02				
mt109	h/zr.10t	zr/h.10t			
c	----- Fuel Rod : 11761 -----				---
m110	92234.70c	9.9210E-06	92235.70c	1.0826E-03	92236.70c 1.2023E-05
	92238.70c	4.3282E-03	5010.70c	7.6279E-08	5011.70c 3.0703E-07
	1001.70c	5.0313E-02	1002.70c	5.7867E-06	6000.70c 1.1141E-03
	40090.70c	1.6489E-02	40091.70c	3.5959E-03	40092.70c 5.4963E-03
	40094.70c	5.5701E-03	40096.70c	8.9736E-04	68162.70c 3.2518E-07
	68164.70c	3.7396E-06	68166.70c	7.8067E-05	68167.70c 5.3260E-05
	68168.70c	6.2203E-05	68170.70c	3.4678E-05	72174.70c 1.3209E-09
	72176.70c	4.3425E-08	72177.70c	1.5356E-07	72178.70c 2.2522E-07
	72179.70c	1.1244E-07	72180.70c	2.8961E-07	
c	Total 8.9148E-02				
mt110	h/zr.10t	zr/h.10t			
c	----- Fuel Rod : 11762 -----				---
m111	92234.70c	9.9355E-06	92235.70c	1.0835E-03	92236.70c 1.2040E-05
	92238.70c	4.3352E-03	5010.70c	7.6390E-08	5011.70c 3.0748E-07
	1001.70c	5.0400E-02	1002.70c	5.7967E-06	6000.70c 1.0437E-03
	40090.70c	1.6518E-02	40091.70c	3.6021E-03	40092.70c 5.5059E-03
	40094.70c	5.5797E-03	40096.70c	8.9892E-04	68162.70c 3.2565E-07
	68164.70c	3.7450E-06	68166.70c	7.8180E-05	68167.70c 5.3337E-05
	68168.70c	6.2293E-05	68170.70c	3.4729E-05	72174.70c 1.3232E-09
	72176.70c	4.3501E-08	72177.70c	1.5382E-07	72178.70c 2.2561E-07
	72179.70c	1.1264E-07	72180.70c	2.9011E-07	
c	Total 8.9229E-02				
mt111	h/zr.10t	zr/h.10t			
c	----- Fuel Rod : 11763 -----				---
m112	92234.70c	9.9392E-06	92235.70c	1.0839E-03	92236.70c 1.2045E-05
	92238.70c	4.3369E-03	5010.70c	7.6419E-08	5011.70c 3.0760E-07
	1001.70c	5.0736E-02	1002.70c	5.8353E-06	6000.70c 1.0441E-03
	40090.70c	1.6522E-02	40091.70c	3.6031E-03	40092.70c 5.5074E-03
	40094.70c	5.5813E-03	40096.70c	8.9917E-04	68162.70c 3.2578E-07
	68164.70c	3.7464E-06	68166.70c	7.8210E-05	68167.70c 5.3358E-05
	68168.70c	6.2317E-05	68170.70c	3.4742E-05	72174.70c 1.3236E-09
	72176.70c	4.3513E-08	72177.70c	1.5387E-07	72178.70c 2.2567E-07
	72179.70c	1.1267E-07	72180.70c	2.9020E-07	
c	Total 8.9575E-02				
mt112	h/zr.10t	zr/h.10t			
c	----- Fuel Rod : 11764 -----				---
m113	92234.70c	9.9328E-06	92235.70c	1.0832E-03	92236.70c 1.2037E-05
	92238.70c	4.3341E-03	5010.70c	7.6369E-08	5011.70c 3.0740E-07
	1001.70c	5.1018E-02	1002.70c	5.8677E-06	6000.70c 1.0435E-03
	40090.70c	1.6510E-02	40091.70c	3.6004E-03	40092.70c 5.5032E-03
	40094.70c	5.5770E-03	40096.70c	8.9848E-04	68162.70c 3.2557E-07
	68164.70c	3.7440E-06	68166.70c	7.8159E-05	68167.70c 5.3323E-05
	68168.70c	6.2276E-05	68170.70c	3.4719E-05	72174.70c 1.3226E-09
	72176.70c	4.3480E-08	72177.70c	1.5375E-07	72178.70c 2.2550E-07
	72179.70c	1.1258E-07	72180.70c	2.8997E-07	
c	Total 8.9829E-02				
mt113	h/zr.10t	zr/h.10t			
c	----- Fuel Rod : 11765 -----				---
m114	92234.70c	9.9299E-06	92235.70c	1.0828E-03	92236.70c 1.2033E-05
	92238.70c	4.3328E-03	5010.70c	7.6347E-08	5011.70c 3.0730E-07
	1001.70c	5.1002E-02	1002.70c	5.8660E-06	6000.70c 1.0432E-03
	40090.70c	1.6505E-02	40091.70c	3.5993E-03	40092.70c 5.5016E-03
	40094.70c	5.5753E-03	40096.70c	8.9821E-04	68162.70c 3.2547E-07
	68164.70c	3.7429E-06	68166.70c	7.8136E-05	68167.70c 5.3307E-05
	68168.70c	6.2258E-05	68170.70c	3.4709E-05	72174.70c 1.3222E-09
	72176.70c	4.3467E-08	72177.70c	1.5370E-07	72178.70c 2.2543E-07
	72179.70c	1.1255E-07	72180.70c	2.8989E-07	
c	Total 8.9802E-02				
mt114	h/zr.10t	zr/h.10t			
c	----- Fuel Rod : 11766 -----				---
m115	92234.70c	9.9374E-06	92235.70c	1.0836E-03	92236.70c 1.2043E-05
	92238.70c	4.3361E-03	5010.70c	7.6405E-08	5011.70c 3.0754E-07
	1001.70c	5.0726E-02	1002.70c	5.8342E-06	6000.70c 1.0440E-03
	40090.70c	1.6519E-02	40091.70c	3.6024E-03	40092.70c 5.5064E-03
	40094.70c	5.5802E-03	40096.70c	8.9900E-04	68162.70c 3.2572E-07
	68164.70c	3.7458E-06	68166.70c	7.8196E-05	68167.70c 5.3348E-05
	68168.70c	6.2305E-05	68170.70c	3.4735E-05	72174.70c 1.3233E-09

Fundamental - FUND

NRAD-FUND-RESR-001
CRIT-REAC-COEF

	72176.70c	4.3505E-08	72177.70c	1.5384E-07	72178.70c	2.2563E-07	
	72179.70c	1.1265E-07	72180.70c	2.9014E-07			
c	Total 8.9559E-02						
mt115	h/zr.10t	zr/h.10t					
c	----- Fuel Rod : 11767 -----						---
m116	92234.70c	9.9272E-06	92235.70c	1.0826E-03	92236.70c	1.2030E-05	
	92238.70c	4.3316E-03	5010.70c	7.6327E-08	5011.70c	3.0723E-07	
	1001.70c	5.0359E-02	1002.70c	5.7920E-06	6000.70c	1.0429E-03	
	40090.70c	1.6504E-02	40091.70c	3.5992E-03	40092.70c	5.5014E-03	
	40094.70c	5.5752E-03	40096.70c	8.9818E-04	68162.70c	3.2539E-07	
	68164.70c	3.7419E-06	68166.70c	7.8116E-05	68167.70c	5.3294E-05	
	68168.70c	6.2242E-05	68170.70c	3.4700E-05	72174.70c	1.3221E-09	
	72176.70c	4.3465E-08	72177.70c	1.5370E-07	72178.70c	2.2542E-07	
	72179.70c	1.1255E-07	72180.70c	2.8988E-07			
c	Total 8.9156E-02						
mt116	h/zr.10t	zr/h.10t					
c	----- Fuel Rod : 11768 -----						---
m117	92234.70c	9.9193E-06	92235.70c	1.0832E-03	92236.70c	1.2021E-05	
	92238.70c	4.3267E-03	5010.70c	7.6224E-08	5011.70c	3.0681E-07	
	1001.70c	5.0293E-02	1002.70c	5.7844E-06	6000.70c	1.0056E-03	
	40090.70c	1.6483E-02	40091.70c	3.5944E-03	40092.70c	5.4942E-03	
	40094.70c	5.5679E-03	40096.70c	8.9701E-04	68162.70c	3.2133E-07	
	68164.70c	3.6953E-06	68166.70c	7.7143E-05	68167.70c	5.2630E-05	
	68168.70c	6.1467E-05	68170.70c	3.4268E-05	72174.70c	1.3204E-09	
	72176.70c	4.3408E-08	72177.70c	1.5350E-07	72178.70c	2.2513E-07	
	72179.70c	1.1240E-07	72180.70c	2.8950E-07			
c	Total 8.9003E-02						
mt117	h/zr.10t	zr/h.10t					
c	----- Fuel Rod : 11769 -----						---
m118	92234.70c	9.9035E-06	92235.70c	1.0814E-03	92236.70c	1.2002E-05	
	92238.70c	4.3199E-03	5010.70c	7.6102E-08	5011.70c	3.0632E-07	
	1001.70c	5.0206E-02	1002.70c	5.7743E-06	6000.70c	1.0398E-03	
	40090.70c	1.6454E-02	40091.70c	3.5882E-03	40092.70c	5.4846E-03	
	40094.70c	5.5582E-03	40096.70c	8.9545E-04	68162.70c	3.2082E-07	
	68164.70c	3.6894E-06	68166.70c	7.7020E-05	68167.70c	5.2546E-05	
	68168.70c	6.1368E-05	68170.70c	3.4213E-05	72174.70c	1.3181E-09	
	72176.70c	4.3333E-08	72177.70c	1.5323E-07	72178.70c	2.2474E-07	
	72179.70c	1.1220E-07	72180.70c	2.8899E-07			
c	Total 8.8885E-02						
mt118	h/zr.10t	zr/h.10t					
c	----- Fuel Rod : 11770 -----						---
m119	92234.70c	9.9257E-06	92235.70c	1.0839E-03	92236.70c	1.2028E-05	
	92238.70c	4.3294E-03	5010.70c	7.6273E-08	5011.70c	3.0701E-07	
	1001.70c	5.0949E-02	1002.70c	5.8598E-06	6000.70c	1.0422E-03	
	40090.70c	1.6487E-02	40091.70c	3.5955E-03	40092.70c	5.4958E-03	
	40094.70c	5.5695E-03	40096.70c	8.9727E-04	68162.70c	3.2154E-07	
	68164.70c	3.6977E-06	68166.70c	7.7193E-05	68167.70c	5.2664E-05	
	68168.70c	6.1507E-05	68170.70c	3.4290E-05	72174.70c	1.3208E-09	
	72176.70c	4.3421E-08	72177.70c	1.5354E-07	72178.70c	2.2519E-07	
	72179.70c	1.1243E-07	72180.70c	2.8958E-07			
c	Total 8.9709E-02						
mt119	h/zr.10t	zr/h.10t					
c	----- Fuel Rod : 11771 -----						---
m120	92234.70c	9.9124E-06	92235.70c	1.0824E-03	92236.70c	1.2012E-05	
	92238.70c	4.3238E-03	5010.70c	7.6169E-08	5011.70c	3.0659E-07	
	1001.70c	5.0565E-02	1002.70c	5.8156E-06	6000.70c	1.0407E-03	
	40090.70c	1.6467E-02	40091.70c	3.5910E-03	40092.70c	5.4889E-03	
	40094.70c	5.5625E-03	40096.70c	8.9614E-04	68162.70c	3.2111E-07	
	68164.70c	3.6927E-06	68166.70c	7.7088E-05	68167.70c	5.2593E-05	
	68168.70c	6.1423E-05	68170.70c	3.4244E-05	72174.70c	1.3191E-09	
	72176.70c	4.3366E-08	72177.70c	1.5335E-07	72178.70c	2.2491E-07	
	72179.70c	1.1229E-07	72180.70c	2.8922E-07			
c	Total 8.9275E-02						
mt120	h/zr.10t	zr/h.10t					
c	----- Fuel Rod : 11772 -----						---
m121	92234.70c	9.9263E-06	92235.70c	1.0839E-03	92236.70c	1.2029E-05	
	92238.70c	4.3298E-03	5010.70c	7.6277E-08	5011.70c	3.0702E-07	
	1001.70c	5.0321E-02	1002.70c	5.7876E-06	6000.70c	1.0422E-03	
	40090.70c	1.6492E-02	40091.70c	3.5964E-03	40092.70c	5.4972E-03	
	40094.70c	5.5709E-03	40096.70c	8.9750E-04	68162.70c	3.2156E-07	

Fundamental - FUND

NRAD-FUND-RESR-001
CRIT-REAC-COEF

	68164.70c	3.6979E-06	68166.70c	7.7197E-05	68167.70c	5.2667E-05
	68168.70c	6.1509E-05	68170.70c	3.4292E-05	72174.70c	1.3211E-09
	72176.70c	4.3432E-08	72177.70c	1.5358E-07	72178.70c	2.2525E-07
	72179.70c	1.1246E-07	72180.70c	2.8966E-07		
c	Total 8.9089E-02					
mt121	h/zr.10t	zr/h.10t				
c	----- Fuel Rod : 11773 -----					
m122	92234.70c	9.9165E-06	92235.70c	1.0829E-03	92236.70c	1.2017E-05
	92238.70c	4.3255E-03	5010.70c	7.6200E-08	5011.70c	3.0672E-07
	1001.70c	5.0585E-02	1002.70c	5.8180E-06	6000.70c	1.0412E-03
	40090.70c	1.6473E-02	40091.70c	3.5924E-03	40092.70c	5.4911E-03
	40094.70c	5.5647E-03	40096.70c	8.9650E-04	68162.70c	3.2124E-07
	68164.70c	3.6942E-06	68166.70c	7.7120E-05	68167.70c	5.2614E-05
	68168.70c	6.1448E-05	68170.70c	3.4258E-05	72174.70c	1.3197E-09
	72176.70c	4.3384E-08	72177.70c	1.5341E-07	72178.70c	2.2500E-07
	72179.70c	1.1234E-07	72180.70c	2.8933E-07		
c	Total 8.9311E-02					
mt122	h/zr.10t	zr/h.10t				
c	----- Fuel Rod : 11774 -----					
m123	92234.70c	9.9213E-06	92235.70c	1.0834E-03	92236.70c	1.2023E-05
	92238.70c	4.3276E-03	5010.70c	7.6239E-08	5011.70c	3.0687E-07
	1001.70c	5.1555E-02	1002.70c	5.9295E-06	6000.70c	1.0417E-03
	40090.70c	1.6476E-02	40091.70c	3.5931E-03	40092.70c	5.4921E-03
	40094.70c	5.5658E-03	40096.70c	8.9667E-04	68162.70c	3.2140E-07
	68164.70c	3.6961E-06	68166.70c	7.7159E-05	68167.70c	5.2640E-05
	68168.70c	6.1479E-05	68170.70c	3.4275E-05	72174.70c	1.3199E-09
	72176.70c	4.3392E-08	72177.70c	1.5344E-07	72178.70c	2.2504E-07
	72179.70c	1.1236E-07	72180.70c	2.8939E-07		
c	Total 9.0290E-02					
mt123	h/zr.10t	zr/h.10t				
c	----- Fuel Rod : 11775 -----					
m124	92234.70c	9.8993E-06	92235.70c	1.0809E-03	92236.70c	1.1996E-05
	92238.70c	4.3181E-03	5010.70c	7.6154E-08	5011.70c	3.0653E-07
	1001.70c	5.0564E-02	1002.70c	5.8156E-06	6000.70c	1.0405E-03
	40090.70c	1.6467E-02	40091.70c	3.5909E-03	40092.70c	5.4888E-03
	40094.70c	5.5625E-03	40096.70c	8.9614E-04	68162.70c	3.2826E-07
	68164.70c	3.7749E-06	68166.70c	7.8805E-05	68167.70c	5.3764E-05
	68168.70c	6.2791E-05	68170.70c	3.5006E-05	72174.70c	1.3191E-09
	72176.70c	4.3366E-08	72177.70c	1.5335E-07	72178.70c	2.2491E-07
	72179.70c	1.1229E-07	72180.70c	2.8922E-07		
c	Total 8.9272E-02					
mt124	h/zr.10t	zr/h.10t				
c	----- Fuel Rod : 11776 -----					
m125	92234.70c	9.9241E-06	92235.70c	1.0826E-03	92236.70c	1.2026E-05
	92238.70c	4.3299E-03	5010.70c	7.6428E-08	5011.70c	3.0763E-07
	1001.70c	5.1071E-02	1002.70c	5.8739E-06	6000.70c	1.0803E-03
	40090.70c	1.6527E-02	40091.70c	3.6041E-03	40092.70c	5.5090E-03
	40094.70c	5.5829E-03	40096.70c	8.9943E-04	68162.70c	3.3306E-07
	68164.70c	3.8302E-06	68166.70c	7.9957E-05	68167.70c	5.4550E-05
	68168.70c	6.3709E-05	68170.70c	3.5518E-05	72174.70c	1.3240E-09
	72176.70c	4.3525E-08	72177.70c	1.5391E-07	72178.70c	2.2574E-07
	72179.70c	1.1270E-07	72180.70c	2.9028E-07		
c	Total 8.9953E-02					
mt125	h/zr.10t	zr/h.10t				
c	----- Fuel Rod : 11777 -----					
m126	92234.70c	9.8531E-06	92235.70c	1.0752E-03	92236.70c	1.1940E-05
	92238.70c	4.2986E-03	5010.70c	7.6180E-08	5011.70c	3.0663E-07
	1001.70c	5.0691E-02	1002.70c	5.8301E-06	6000.70c	1.0768E-03
	40090.70c	1.6508E-02	40091.70c	3.5999E-03	40092.70c	5.5026E-03
	40094.70c	5.5764E-03	40096.70c	8.9838E-04	68162.70c	3.2476E-07
	68164.70c	3.7347E-06	68166.70c	7.7965E-05	68167.70c	5.3191E-05
	68168.70c	6.2122E-05	68170.70c	3.4633E-05	72174.70c	1.3224E-09
	72176.70c	4.3475E-08	72177.70c	1.5373E-07	72178.70c	2.2547E-07
	72179.70c	1.1257E-07	72180.70c	2.8994E-07		
c	Total 8.9487E-02					
mt126	h/zr.10t	zr/h.10t				
c	----- Fuel Rod : 11778 -----					
m127	92234.70c	9.9231E-06	92235.70c	1.0825E-03	92236.70c	1.2025E-05
	92238.70c	4.3294E-03	5010.70c	7.6294E-08	5011.70c	3.0709E-07
	1001.70c	5.0623E-02	1002.70c	5.8223E-06	6000.70c	1.1503E-03

Fundamental - FUND

NRAD-FUND-RESR-001
CRIT-REAC-COEF

	40090.70c	1.6485E-02	40091.70c	3.5951E-03	40092.70c	5.4951E-03
	40094.70c	5.5688E-03	40096.70c	8.9717E-04	68162.70c	3.2886E-07
	68164.70c	3.7819E-06	68166.70c	7.8949E-05	68167.70c	5.3862E-05
	68168.70c	6.2906E-05	68170.70c	3.5070E-05	72174.70c	1.3206E-09
	72176.70c	4.3416E-08	72177.70c	1.5352E-07	72178.70c	2.2517E-07
	72179.70c	1.1242E-07	72180.70c	2.8955E-07		
c	Total 8.9490E-02					
mt127	h/zr.10t	zr/h.10t				
c	----- Fuel Rod : 11779 -----					
m128	92234.70c	9.8496E-06	92235.70c	1.0748E-03	92236.70c	1.1936E-05
	92238.70c	4.2971E-03	5010.70c	7.6154E-08	5011.70c	3.0653E-07
	1001.70c	5.0674E-02	1002.70c	5.8282E-06	6000.70c	1.0764E-03
	40090.70c	1.6502E-02	40091.70c	3.5988E-03	40092.70c	5.5008E-03
	40094.70c	5.5745E-03	40096.70c	8.9809E-04	68162.70c	3.2465E-07
	68164.70c	3.7335E-06	68166.70c	7.7939E-05	68167.70c	5.3173E-05
	68168.70c	6.2101E-05	68170.70c	3.4621E-05	72174.70c	1.3220E-09
	72176.70c	4.3460E-08	72177.70c	1.5368E-07	72178.70c	2.2540E-07
	72179.70c	1.1253E-07	72180.70c	2.8985E-07		
c	Total 8.9458E-02					
mt128	h/zr.10t	zr/h.10t				
c	----- Fuel Rod : 11780 -----					
m129	92234.70c	9.9194E-06	92235.70c	1.0821E-03	92236.70c	1.2021E-05
	92238.70c	4.3279E-03	5010.70c	7.6267E-08	5011.70c	3.0698E-07
	1001.70c	5.0290E-02	1002.70c	5.7841E-06	6000.70c	1.1499E-03
	40090.70c	1.6482E-02	40091.70c	3.5942E-03	40092.70c	5.4939E-03
	40094.70c	5.5675E-03	40096.70c	8.9696E-04	68162.70c	3.2874E-07
	68164.70c	3.7805E-06	68166.70c	7.8922E-05	68167.70c	5.3843E-05
	68168.70c	6.2884E-05	68170.70c	3.5058E-05	72174.70c	1.3203E-09
	72176.70c	4.3406E-08	72177.70c	1.5349E-07	72178.70c	2.2512E-07
	72179.70c	1.1239E-07	72180.70c	2.8948E-07		
c	Total 8.9148E-02					
mt129	h/zr.10t	zr/h.10t				
c	----- Fuel Rod : 11781 -----					
m130	92234.70c	9.8850E-06	92235.70c	1.0789E-03	92236.70c	1.1979E-05
	92238.70c	4.3122E-03	5010.70c	7.6155E-08	5011.70c	3.0653E-07
	1001.70c	5.0582E-02	1002.70c	5.8176E-06	6000.70c	1.0764E-03
	40090.70c	1.6472E-02	40091.70c	3.5922E-03	40092.70c	5.4908E-03
	40094.70c	5.5644E-03	40096.70c	8.9645E-04	68162.70c	3.3187E-07
	68164.70c	3.8165E-06	68166.70c	7.9672E-05	68167.70c	5.4355E-05
	68168.70c	6.3481E-05	68170.70c	3.5391E-05	72174.70c	1.3196E-09
	72176.70c	4.3381E-08	72177.70c	1.5340E-07	72178.70c	2.2499E-07
	72179.70c	1.1233E-07	72180.70c	2.8932E-07		
c	Total 8.9332E-02					
mt130	h/zr.10t	zr/h.10t				
c	----- Fuel Rod : 11782 -----					
m131	92234.70c	9.9487E-06	92235.70c	1.0858E-03	92236.70c	1.2056E-05
	92238.70c	4.3401E-03	5010.70c	7.6280E-08	5011.70c	3.0704E-07
	1001.70c	5.0260E-02	1002.70c	5.7806E-06	6000.70c	1.1141E-03
	40090.70c	1.6472E-02	40091.70c	3.5921E-03	40092.70c	5.4906E-03
	40094.70c	5.5642E-03	40096.70c	8.9642E-04	68162.70c	3.2157E-07
	68164.70c	3.6981E-06	68166.70c	7.7200E-05	68167.70c	5.2669E-05
	68168.70c	6.1512E-05	68170.70c	3.4293E-05	72174.70c	1.3195E-09
	72176.70c	4.3380E-08	72177.70c	1.5340E-07	72178.70c	2.2498E-07
	72179.70c	1.1233E-07	72180.70c	2.8931E-07		
c	Total 8.9074E-02					
mt131	h/zr.10t	zr/h.10t				
c	----- Fuel Rod : 11783 -----					
m132	92234.70c	9.9499E-06	92235.70c	1.0859E-03	92236.70c	1.2058E-05
	92238.70c	4.3407E-03	5010.70c	7.6289E-08	5011.70c	3.0707E-07
	1001.70c	5.0266E-02	1002.70c	5.7812E-06	6000.70c	1.1143E-03
	40090.70c	1.6474E-02	40091.70c	3.5925E-03	40092.70c	5.4912E-03
	40094.70c	5.5648E-03	40096.70c	8.9652E-04	68162.70c	3.2161E-07
	68164.70c	3.6985E-06	68166.70c	7.7209E-05	68167.70c	5.2675E-05
	68168.70c	6.1519E-05	68170.70c	3.4297E-05	72174.70c	1.3197E-09
	72176.70c	4.3385E-08	72177.70c	1.5341E-07	72178.70c	2.2501E-07
	72179.70c	1.1234E-07	72180.70c	2.8934E-07		
c	Total 8.9084E-02					
mt132	h/zr.10t	zr/h.10t				
c	----- Fuel Rod : 11784 -----					
m133	92234.70c	9.9602E-06	92235.70c	1.0871E-03	92236.70c	1.2070E-05

Fundamental - FUND

NRAD-FUND-RESR-001
CRIT-REAC-COEF

	92238.70c	4.3451E-03	5010.70c	7.6367E-08	5011.70c	3.0739E-07
	1001.70c	5.0317E-02	1002.70c	5.7871E-06	6000.70c	1.1154E-03
	40090.70c	1.6490E-02	40091.70c	3.5961E-03	40092.70c	5.4967E-03
	40094.70c	5.5705E-03	40096.70c	8.9743E-04	68162.70c	3.2194E-07
	68164.70c	3.7023E-06	68166.70c	7.7288E-05	68167.70c	5.2729E-05
	68168.70c	6.1582E-05	68170.70c	3.4332E-05	72174.70c	1.3210E-09
	72176.70c	4.3428E-08	72177.70c	1.5357E-07	72178.70c	2.2523E-07
	72179.70c	1.1245E-07	72180.70c	2.8963E-07		
c	Total 8.9174E-02					
mt133	h/zr.10t	zr/h.10t				
c						
c	----- Fuel Rod : 11785 -----					
m134	92234.70c	9.9643E-06	92235.70c	1.0881E-03	92236.70c	1.2075E-05
	92238.70c	4.3464E-03	5010.70c	7.6356E-08	5011.70c	3.0734E-07
	1001.70c	5.0283E-02	1002.70c	5.7832E-06	6000.70c	1.1512E-03
	40090.70c	1.6479E-02	40091.70c	3.5937E-03	40092.70c	5.4931E-03
	40094.70c	5.5667E-03	40096.70c	8.9683E-04	68162.70c	3.2551E-07
	68164.70c	3.7434E-06	68166.70c	7.8145E-05	68167.70c	5.3314E-05
	68168.70c	6.2265E-05	68170.70c	3.4713E-05	72174.70c	1.3201E-09
	72176.70c	4.3399E-08	72177.70c	1.5347E-07	72178.70c	2.2508E-07
	72179.70c	1.1238E-07	72180.70c	2.8944E-07		
c	Total 8.9160E-02					
mt134	h/zr.10t	zr/h.10t				
c						
c	----- Fuel Rod : 11786 -----					
m135	92234.70c	9.9720E-06	92235.70c	1.0889E-03	92236.70c	1.2085E-05
	92238.70c	4.3497E-03	5010.70c	7.6416E-08	5011.70c	3.0758E-07
	1001.70c	5.0638E-02	1002.70c	5.8241E-06	6000.70c	1.1521E-03
	40090.70c	1.6491E-02	40091.70c	3.5962E-03	40092.70c	5.4968E-03
	40094.70c	5.5706E-03	40096.70c	8.9744E-04	68162.70c	3.2577E-07
	68164.70c	3.7463E-06	68166.70c	7.8207E-05	68167.70c	5.3356E-05
	68168.70c	6.2314E-05	68170.70c	3.4741E-05	72174.70c	1.3210E-09
	72176.70c	4.3429E-08	72177.70c	1.5357E-07	72178.70c	2.2524E-07
	72179.70c	1.1245E-07	72180.70c	2.8964E-07		
c	Total 8.9542E-02					
mt135	h/zr.10t	zr/h.10t				
c						
c	----- Fuel Rod : 11787 -----					
m136	92234.70c	9.8808E-06	92235.70c	1.0784E-03	92236.70c	1.1974E-05
	92238.70c	4.3104E-03	5010.70c	7.6121E-08	5011.70c	3.0640E-07
	1001.70c	5.0244E-02	1002.70c	5.7788E-06	6000.70c	1.0759E-03
	40090.70c	1.6467E-02	40091.70c	3.5909E-03	40092.70c	5.4888E-03
	40094.70c	5.5625E-03	40096.70c	8.9614E-04	68162.70c	3.3172E-07
	68164.70c	3.8147E-06	68166.70c	7.9636E-05	68167.70c	5.4331E-05
	68168.70c	6.3453E-05	68170.70c	3.5375E-05	72174.70c	1.3191E-09
	72176.70c	4.3366E-08	72177.70c	1.5335E-07	72178.70c	2.2491E-07
	72179.70c	1.1229E-07	72180.70c	2.8922E-07		
c	Total 8.8980E-02					
mt136	h/zr.10t	zr/h.10t				
c						
c	----- Fuel Rod : 11788 -----					
m137	92234.70c	9.8831E-06	92235.70c	1.0787E-03	92236.70c	1.1977E-05
	92238.70c	4.3115E-03	5010.70c	7.6141E-08	5011.70c	3.0648E-07
	1001.70c	5.0573E-02	1002.70c	5.8166E-06	6000.70c	1.0762E-03
	40090.70c	1.6469E-02	40091.70c	3.5916E-03	40092.70c	5.4898E-03
	40094.70c	5.5634E-03	40096.70c	8.9630E-04	68162.70c	3.3181E-07
	68164.70c	3.8158E-06	68166.70c	7.9658E-05	68167.70c	5.4345E-05
	68168.70c	6.3470E-05	68170.70c	3.5385E-05	72174.70c	1.3194E-09
	72176.70c	4.3374E-08	72177.70c	1.5337E-07	72178.70c	2.2495E-07
	72179.70c	1.1231E-07	72180.70c	2.8927E-07		
c	Total 8.9316E-02					
mt137	h/zr.10t	zr/h.10t				
c						
c	----- Fuel Rod : 11789 -----					
m138	92234.70c	9.9661E-06	92235.70c	1.0883E-03	92236.70c	1.2077E-05
	92238.70c	4.3471E-03	5010.70c	7.6369E-08	5011.70c	3.0740E-07
	1001.70c	5.0607E-02	1002.70c	5.8204E-06	6000.70c	1.1514E-03
	40090.70c	1.6480E-02	40091.70c	3.5940E-03	40092.70c	5.4934E-03
	40094.70c	5.5671E-03	40096.70c	8.9689E-04	68162.70c	3.2557E-07
	68164.70c	3.7440E-06	68166.70c	7.8159E-05	68167.70c	5.3323E-05
	68168.70c	6.2276E-05	68170.70c	3.4719E-05	72174.70c	1.3202E-09
	72176.70c	4.3402E-08	72177.70c	1.5348E-07	72178.70c	2.2510E-07
	72179.70c	1.1238E-07	72180.70c	2.8946E-07		
c	Total 8.9487E-02					
mt138	h/zr.10t	zr/h.10t				
c						

Fundamental - FUND

NRAD-FUND-RESR-001
CRIT-REAC-COEF

c ----- Fuel Rod : 11790 -----						---
m139	92234.70c	9.9310E-06	92235.70c	1.0855E-03	92236.70c	1.2035E-05
	92238.70c	4.3307E-03	5010.70c	7.6397E-08	5011.70c	3.0751E-07
	1001.70c	5.0733E-02	1002.70c	5.8350E-06	6000.70c	1.0798E-03
	40090.70c	1.6521E-02	40091.70c	3.6029E-03	40092.70c	5.5071E-03
	40094.70c	5.5810E-03	40096.70c	8.9912E-04	68162.70c	3.2207E-07
	68164.70c	3.7038E-06	68166.70c	7.7319E-05	68167.70c	5.2750E-05
	68168.70c	6.1607E-05	68170.70c	3.4346E-05	72174.70c	1.3235E-09
	72176.70c	4.3510E-08	72177.70c	1.5386E-07	72178.70c	2.2566E-07
	72179.70c	1.1266E-07	72180.70c	2.9018E-07		
c Total 8.9600E-02						
mt139	h/zr.10t zr/h.10t					
c ----- Fuel Rod : 11791 -----						---
m140	92234.70c	9.8835E-06	92235.70c	1.0787E-03	92236.70c	1.1977E-05
	92238.70c	4.3117E-03	5010.70c	7.6144E-08	5011.70c	3.0649E-07
	1001.70c	5.0260E-02	1002.70c	5.7806E-06	6000.70c	1.0763E-03
	40090.70c	1.6472E-02	40091.70c	3.5921E-03	40092.70c	5.4905E-03
	40094.70c	5.5642E-03	40096.70c	8.9641E-04	68162.70c	3.3182E-07
	68164.70c	3.8159E-06	68166.70c	7.9660E-05	68167.70c	5.4347E-05
	68168.70c	6.3472E-05	68170.70c	3.5386E-05	72174.70c	1.3195E-09
	72176.70c	4.3379E-08	72177.70c	1.5339E-07	72178.70c	2.2498E-07
	72179.70c	1.1232E-07	72180.70c	2.8931E-07		
c Total 8.9007E-02						
mt140	h/zr.10t zr/h.10t					
c ----- Fuel Rod : 11792 -----						---
m141	92234.70c	9.8794E-06	92235.70c	1.0783E-03	92236.70c	1.1972E-05
	92238.70c	4.3099E-03	5010.70c	7.6115E-08	5011.70c	3.0637E-07
	1001.70c	5.0242E-02	1002.70c	5.7784E-06	6000.70c	1.0759E-03
	40090.70c	1.6466E-02	40091.70c	3.5907E-03	40092.70c	5.4885E-03
	40094.70c	5.5621E-03	40096.70c	8.9609E-04	68162.70c	3.3169E-07
	68164.70c	3.8144E-06	68166.70c	7.9629E-05	68167.70c	5.4326E-05
	68168.70c	6.3448E-05	68170.70c	3.5372E-05	72174.70c	1.3190E-09
	72176.70c	4.3364E-08	72177.70c	1.5334E-07	72178.70c	2.2490E-07
	72179.70c	1.1228E-07	72180.70c	2.8920E-07		
c Total 8.8974E-02						
mt141	h/zr.10t zr/h.10t					
c ----- Fuel Rod : 11793 -----						---
m142	92234.70c	9.8835E-06	92235.70c	1.0787E-03	92236.70c	1.1977E-05
	92238.70c	4.3117E-03	5010.70c	7.6141E-08	5011.70c	3.0648E-07
	1001.70c	5.0573E-02	1002.70c	5.8165E-06	6000.70c	1.0762E-03
	40090.70c	1.6469E-02	40091.70c	3.5915E-03	40092.70c	5.4897E-03
	40094.70c	5.5633E-03	40096.70c	8.9628E-04	68162.70c	3.3181E-07
	68164.70c	3.8158E-06	68166.70c	7.9658E-05	68167.70c	5.4345E-05
	68168.70c	6.3470E-05	68170.70c	3.5385E-05	72174.70c	1.3193E-09
	72176.70c	4.3373E-08	72177.70c	1.5337E-07	72178.70c	2.2495E-07
	72179.70c	1.1231E-07	72180.70c	2.8926E-07		
c Total 8.9315E-02						
mt142	h/zr.10t zr/h.10t					
c ----- Fuel Rod : 11794 -----						---
m143	92234.70c	9.9205E-06	92235.70c	1.0844E-03	92236.70c	1.2022E-05
	92238.70c	4.3262E-03	5010.70c	7.6317E-08	5011.70c	3.0719E-07
	1001.70c	5.0365E-02	1002.70c	5.7926E-06	6000.70c	1.0787E-03
	40090.70c	1.6506E-02	40091.70c	3.5995E-03	40092.70c	5.5020E-03
	40094.70c	5.5757E-03	40096.70c	8.9828E-04	68162.70c	3.2173E-07
	68164.70c	3.6999E-06	68166.70c	7.7238E-05	68167.70c	5.2694E-05
	68168.70c	6.1542E-05	68170.70c	3.4310E-05	72174.70c	1.3223E-09
	72176.70c	4.3470E-08	72177.70c	1.5371E-07	72178.70c	2.2545E-07
	72179.70c	1.1256E-07	72180.70c	2.8991E-07		
c Total 8.9194E-02						
mt143	h/zr.10t zr/h.10t					
c ----- Fuel Rod : 11795 -----						---
m144	92234.70c	9.9464E-06	92235.70c	1.0870E-03	92236.70c	1.2054E-05
	92238.70c	4.3377E-03	5010.70c	7.6389E-08	5011.70c	3.0748E-07
	1001.70c	5.0684E-02	1002.70c	5.8293E-06	6000.70c	1.0797E-03
	40090.70c	1.6505E-02	40091.70c	3.5994E-03	40092.70c	5.5018E-03
	40094.70c	5.5756E-03	40096.70c	8.9825E-04	68162.70c	3.2565E-07
	68164.70c	3.7450E-06	68166.70c	7.8179E-05	68167.70c	5.3337E-05
	68168.70c	6.2292E-05	68170.70c	3.4728E-05	72174.70c	1.3222E-09
	72176.70c	4.3468E-08	72177.70c	1.5371E-07	72178.70c	2.2544E-07
	72179.70c	1.1255E-07	72180.70c	2.8990E-07		
c Total 8.9530E-02						

Fundamental - FUND

NRAD-FUND-RESR-001
CRIT-REAC-COEF

```

mt144 h/zr.10t zr/h.10t
c
c ----- Fuel Rod : 11796 -----
m145 92234.70c 9.9423E-06 92235.70c 1.0866E-03 92236.70c 1.2049E-05
      92238.70c 4.3359E-03 5010.70c 7.6357E-08 5011.70c 3.0735E-07
      1001.70c 5.0977E-02 1002.70c 5.8631E-06 6000.70c 1.0793E-03
      40090.70c 1.6497E-02 40091.70c 3.5975E-03 40092.70c 5.4989E-03
      40094.70c 5.5726E-03 40096.70c 8.9777E-04 68162.70c 3.2551E-07
      68164.70c 3.7434E-06 68166.70c 7.8147E-05 68167.70c 5.3315E-05
      68168.70c 6.2266E-05 68170.70c 3.4714E-05 72174.70c 1.3215E-09
      72176.70c 4.3445E-08 72177.70c 1.5363E-07 72178.70c 2.2532E-07
      72179.70c 1.1250E-07 72180.70c 2.8975E-07
c
c Total 8.9804E-02
mt145 h/zr.10t zr/h.10t
c
c ----- Fuel Rod : 11797 -----
m146 92234.70c 9.9512E-06 92235.70c 1.0876E-03 92236.70c 1.2059E-05
      92238.70c 4.3397E-03 5010.70c 7.6427E-08 5011.70c 3.0763E-07
      1001.70c 5.0709E-02 1002.70c 5.8322E-06 6000.70c 1.0803E-03
      40090.70c 1.6514E-02 40091.70c 3.6012E-03 40092.70c 5.5045E-03
      40094.70c 5.5783E-03 40096.70c 8.9869E-04 68162.70c 3.2581E-07
      68164.70c 3.7468E-06 68166.70c 7.8218E-05 68167.70c 5.3363E-05
      68168.70c 6.2323E-05 68170.70c 3.4745E-05 72174.70c 1.3229E-09
      72176.70c 4.3490E-08 72177.70c 1.5379E-07 72178.70c 2.2555E-07
      72179.70c 1.1261E-07 72180.70c 2.9004E-07
c
c Total 8.9574E-02
mt146 h/zr.10t zr/h.10t
c
c ----- Fuel Rod : 11798 -----
m147 92234.70c 9.9348E-06 92235.70c 1.0858E-03 92236.70c 1.2039E-05
      92238.70c 4.3326E-03 5010.70c 7.6299E-08 5011.70c 3.0711E-07
      1001.70c 5.0946E-02 1002.70c 5.8595E-06 6000.70c 1.0066E-03
      40090.70c 1.6487E-02 40091.70c 3.5953E-03 40092.70c 5.4955E-03
      40094.70c 5.5692E-03 40096.70c 8.9723E-04 68162.70c 3.2888E-07
      68164.70c 3.7821E-06 68166.70c 7.8955E-05 68167.70c 5.3866E-05
      68168.70c 6.2910E-05 68170.70c 3.5073E-05 72174.70c 1.3207E-09
      72176.70c 4.3419E-08 72177.70c 1.5353E-07 72178.70c 2.2518E-07
      72179.70c 1.1243E-07 72180.70c 2.8957E-07
c
c Total 8.9679E-02
mt147 h/zr.10t zr/h.10t
c
c ----- Fuel Rod : 11799 -----
m148 92234.70c 9.8641E-06 92235.70c 1.0765E-03 92236.70c 1.1954E-05
      92238.70c 4.3032E-03 5010.70c 7.5993E-08 5011.70c 3.0588E-07
      1001.70c 5.0788E-02 1002.70c 5.8413E-06 6000.70c 1.0741E-03
      40090.70c 1.6435E-02 40091.70c 3.5841E-03 40092.70c 5.4784E-03
      40094.70c 5.5519E-03 40096.70c 8.9444E-04 68162.70c 3.3116E-07
      68164.70c 3.8083E-06 68166.70c 7.9502E-05 68167.70c 5.4239E-05
      68168.70c 6.3346E-05 68170.70c 3.5316E-05 72174.70c 1.3166E-09
      72176.70c 4.3284E-08 72177.70c 1.5306E-07 72178.70c 2.2448E-07
      72179.70c 1.1208E-07 72180.70c 2.8867E-07
c
c Total 8.9451E-02
mt148 h/zr.10t zr/h.10t
c
c ----- Fuel Rod : 11800 -----
m149 92234.70c 1.0019E-05 92235.70c 1.0934E-03 92236.70c 1.2141E-05
      92238.70c 4.3707E-03 5010.70c 7.6345E-08 5011.70c 3.0730E-07
      1001.70c 5.0490E-02 1002.70c 5.8070E-06 6000.70c 1.0431E-03
      40090.70c 1.6442E-02 40091.70c 3.5856E-03 40092.70c 5.4807E-03
      40094.70c 5.5542E-03 40096.70c 8.9481E-04 68162.70c 3.2546E-07
      68164.70c 3.7428E-06 68166.70c 7.8134E-05 68167.70c 5.3306E-05
      68168.70c 6.2257E-05 68170.70c 3.4708E-05 72174.70c 1.3172E-09
      72176.70c 4.3302E-08 72177.70c 1.5312E-07 72178.70c 2.2458E-07
      72179.70c 1.1212E-07 72180.70c 2.8879E-07
c
c Total 8.9216E-02
mt149 h/zr.10t zr/h.10t
c
c ----- Fuel Rod : 11801 -----
m150 92234.70c 9.9357E-06 92235.70c 1.0864E-03 92236.70c 1.2041E-05
      92238.70c 4.3325E-03 5010.70c 7.6306E-08 5011.70c 3.0714E-07
      1001.70c 5.0651E-02 1002.70c 5.8255E-06 6000.70c 9.7070E-04
      40090.70c 1.6495E-02 40091.70c 3.5971E-03 40092.70c 5.4982E-03
      40094.70c 5.5719E-03 40096.70c 8.9767E-04 68162.70c 3.2530E-07
      68164.70c 3.7409E-06 68166.70c 7.8095E-05 68167.70c 5.3279E-05
      68168.70c 6.2225E-05 68170.70c 3.4691E-05 72174.70c 1.3214E-09
      72176.70c 4.3440E-08 72177.70c 1.5361E-07 72178.70c 2.2529E-07

```

Fundamental - FUND

NRAD-FUND-RESR-001
CRIT-REAC-COEF

	72179.70c	1.1248E-07	72180.70c	2.8971E-07		
c	Total 8.9361E-02					
mt150	h/zr.10t	zr/h.10t				
c	----- Fuel Rod : 11802 -----					---
m151	92234.70c	1.0000E-05	92235.70c	1.0942E-03	92236.70c	1.2119E-05
	92238.70c	4.3598E-03	5010.70c	7.6333E-08	5011.70c	3.0725E-07
	1001.70c	5.0204E-02	1002.70c	5.7742E-06	6000.70c	9.3508E-04
	40090.70c	1.6453E-02	40091.70c	3.5881E-03	40092.70c	5.4845E-03
	40094.70c	5.5580E-03	40096.70c	8.9542E-04	68162.70c	3.3626E-07
	68164.70c	3.8670E-06	68166.70c	8.0726E-05	68167.70c	5.5074E-05
	68168.70c	6.4321E-05	68170.70c	3.5859E-05	72174.70c	1.3181E-09
	72176.70c	4.3332E-08	72177.70c	1.5323E-07	72178.70c	2.2473E-07
	72179.70c	1.1220E-07	72180.70c	2.8899E-07		
c	Total 8.8842E-02					
mt151	h/zr.10t	zr/h.10t				
c	----- Fuel Rod : 11803 -----					---
m152	92234.70c	9.9943E-06	92235.70c	1.0936E-03	92236.70c	1.2111E-05
	92238.70c	4.3572E-03	5010.70c	7.6288E-08	5011.70c	3.0707E-07
	1001.70c	5.0489E-02	1002.70c	5.8069E-06	6000.70c	9.3453E-04
	40090.70c	1.6442E-02	40091.70c	3.5856E-03	40092.70c	5.4807E-03
	40094.70c	5.5542E-03	40096.70c	8.9480E-04	68162.70c	3.3606E-07
	68164.70c	3.8647E-06	68166.70c	8.0678E-05	68167.70c	5.5042E-05
	68168.70c	6.4284E-05	68170.70c	3.5838E-05	72174.70c	1.3172E-09
	72176.70c	4.3301E-08	72177.70c	1.5312E-07	72178.70c	2.2457E-07
	72179.70c	1.1212E-07	72180.70c	2.8879E-07		
c	Total 8.9101E-02					
mt152	h/zr.10t	zr/h.10t				
c	----- Fuel Rod : 11804 -----					---
m153	92234.70c	9.9156E-06	92235.70c	1.0824E-03	92236.70c	1.2016E-05
	92238.70c	4.3255E-03	5010.70c	7.6236E-08	5011.70c	3.0686E-07
	1001.70c	5.0314E-02	1002.70c	5.7867E-06	6000.70c	9.6981E-04
	40090.70c	1.6489E-02	40091.70c	3.5959E-03	40092.70c	5.4964E-03
	40094.70c	5.5701E-03	40096.70c	8.9737E-04	68162.70c	3.2500E-07
	68164.70c	3.7375E-06	68166.70c	7.8023E-05	68167.70c	5.3230E-05
	68168.70c	6.2168E-05	68170.70c	3.4659E-05	72174.70c	1.3209E-09
	72176.70c	4.3426E-08	72177.70c	1.5356E-07	72178.70c	2.2522E-07
	72179.70c	1.1244E-07	72180.70c	2.8962E-07		
c	Total 8.9001E-02					
mt153	h/zr.10t	zr/h.10t				
c	----- Fuel Rod : 11805 -----					---
m154	92234.70c	9.9329E-06	92235.70c	1.0843E-03	92236.70c	1.2037E-05
	92238.70c	4.3330E-03	5010.70c	7.6371E-08	5011.70c	3.0740E-07
	1001.70c	5.0718E-02	1002.70c	5.8332E-06	6000.70c	9.7152E-04
	40090.70c	1.6517E-02	40091.70c	3.6019E-03	40092.70c	5.5055E-03
	40094.70c	5.5793E-03	40096.70c	8.9886E-04	68162.70c	3.2557E-07
	68164.70c	3.7441E-06	68166.70c	7.8160E-05	68167.70c	5.3324E-05
	68168.70c	6.2277E-05	68170.70c	3.4720E-05	72174.70c	1.3231E-09
	72176.70c	4.3498E-08	72177.70c	1.5381E-07	72178.70c	2.2559E-07
	72179.70c	1.1263E-07	72180.70c	2.9010E-07		
c	Total 8.9470E-02					
mt154	h/zr.10t	zr/h.10t				
c	----- Fuel Rod : 11806 -----					---
m155	92234.70c	9.9639E-06	92235.70c	1.0883E-03	92236.70c	1.2075E-05
	92238.70c	4.3460E-03	5010.70c	7.6352E-08	5011.70c	3.0733E-07
	1001.70c	5.0603E-02	1002.70c	5.8200E-06	6000.70c	1.0792E-03
	40090.70c	1.6479E-02	40091.70c	3.5937E-03	40092.70c	5.4930E-03
	40094.70c	5.5666E-03	40096.70c	8.9681E-04	68162.70c	3.2911E-07
	68164.70c	3.7848E-06	68166.70c	7.9010E-05	68167.70c	5.3904E-05
	68168.70c	6.2954E-05	68170.70c	3.5097E-05	72174.70c	1.3201E-09
	72176.70c	4.3399E-08	72177.70c	1.5346E-07	72178.70c	2.2508E-07
	72179.70c	1.1237E-07	72180.70c	2.8943E-07		
c	Total 8.9409E-02					
mt155	h/zr.10t	zr/h.10t				
c	----- Fuel Rod : 11807 -----					---
m156	92234.70c	9.9780E-06	92235.70c	1.0898E-03	92236.70c	1.2092E-05
	92238.70c	4.3521E-03	5010.70c	7.6459E-08	5011.70c	3.0776E-07
	1001.70c	5.0673E-02	1002.70c	5.8281E-06	6000.70c	1.0807E-03
	40090.70c	1.6502E-02	40091.70c	3.5987E-03	40092.70c	5.5007E-03
	40094.70c	5.5744E-03	40096.70c	8.9807E-04	68162.70c	3.2957E-07
	68164.70c	3.7901E-06	68166.70c	7.9121E-05	68167.70c	5.3979E-05

Fundamental - FUND

NRAD-FUND-RESR-001
CRIT-REAC-COEF

	68168.70c	6.3042E-05	68170.70c	3.5146E-05	72174.70c	1.3220E-09
	72176.70c	4.3460E-08	72177.70c	1.5368E-07	72178.70c	2.2539E-07
	72179.70c	1.1253E-07	72180.70c	2.8984E-07		
c	Total 8.9534E-02					
mt156	h/zr.10t zr/h.10t					
c						
c	----- Fuel Rod : 11808 -----					
m157	92234.70c	9.9111E-06	92235.70c	1.0833E-03	92236.70c	1.2011E-05
	92238.70c	4.3221E-03	5010.70c	7.6201E-08	5011.70c	3.0672E-07
	1001.70c	5.0561E-02	1002.70c	5.8152E-06	6000.70c	1.1130E-03
	40090.70c	1.6465E-02	40091.70c	3.5907E-03	40092.70c	5.4885E-03
	40094.70c	5.5621E-03	40096.70c	8.9607E-04	68162.70c	3.3207E-07
	68164.70c	3.8188E-06	68166.70c	7.9720E-05	68167.70c	5.4388E-05
	68168.70c	6.3520E-05	68170.70c	3.5413E-05	72174.70c	1.3190E-09
	72176.70c	4.3363E-08	72177.70c	1.5334E-07	72178.70c	2.2489E-07
	72179.70c	1.1228E-07	72180.70c	2.8920E-07		
c	Total 8.9348E-02					
mt157	h/zr.10t zr/h.10t					
c						
c	----- Fuel Rod : 11809 -----					
m158	92234.70c	9.9292E-06	92235.70c	1.0853E-03	92236.70c	1.2033E-05
	92238.70c	4.3300E-03	5010.70c	7.6339E-08	5011.70c	3.0727E-07
	1001.70c	5.0967E-02	1002.70c	5.8618E-06	6000.70c	1.1150E-03
	40090.70c	1.6493E-02	40091.70c	3.5968E-03	40092.70c	5.4977E-03
	40094.70c	5.5714E-03	40096.70c	8.9758E-04	68162.70c	3.3267E-07
	68164.70c	3.8257E-06	68166.70c	7.9864E-05	68167.70c	5.4486E-05
	68168.70c	6.3634E-05	68170.70c	3.5477E-05	72174.70c	1.3213E-09
	72176.70c	4.3436E-08	72177.70c	1.5360E-07	72178.70c	2.2527E-07
	72179.70c	1.1247E-07	72180.70c	2.8968E-07		
c	Total 8.9820E-02					
mt158	h/zr.10t zr/h.10t					
c						
c	----- Fuel Rod : 11810 -----					
m159	92234.70c	1.0034E-05	92235.70c	1.0957E-03	92236.70c	1.2159E-05
	92238.70c	4.3766E-03	5010.70c	7.6462E-08	5011.70c	3.0777E-07
	1001.70c	5.0852E-02	1002.70c	5.8487E-06	6000.70c	1.0447E-03
	40090.70c	1.6456E-02	40091.70c	3.5887E-03	40092.70c	5.4854E-03
	40094.70c	5.5589E-03	40096.70c	8.9557E-04	68162.70c	3.4045E-07
	68164.70c	3.9151E-06	68166.70c	8.1732E-05	68167.70c	5.5760E-05
	68168.70c	6.5123E-05	68170.70c	3.6306E-05	72174.70c	1.3183E-09
	72176.70c	4.3339E-08	72177.70c	1.5325E-07	72178.70c	2.2477E-07
	72179.70c	1.1222E-07	72180.70c	2.8903E-07		
c	Total 8.9626E-02					
mt159	h/zr.10t zr/h.10t					
c						
c	----- Fuel Rod : 11811 -----					
m160	92234.70c	9.9882E-06	92235.70c	1.0901E-03	92236.70c	1.2104E-05
	92238.70c	4.3574E-03	5010.70c	7.6370E-08	5011.70c	3.0740E-07
	1001.70c	5.1524E-02	1002.70c	5.9260E-06	6000.70c	9.3553E-04
	40090.70c	1.6466E-02	40091.70c	3.5909E-03	40092.70c	5.4888E-03
	40094.70c	5.5624E-03	40096.70c	8.9613E-04	68162.70c	3.3642E-07
	68164.70c	3.8689E-06	68166.70c	8.0765E-05	68167.70c	5.5101E-05
	68168.70c	6.4353E-05	68170.70c	3.5877E-05	72174.70c	1.3191E-09
	72176.70c	4.3366E-08	72177.70c	1.5335E-07	72178.70c	2.2491E-07
	72179.70c	1.1229E-07	72180.70c	2.8922E-07		
c	Total 9.0182E-02					
mt160	h/zr.10t zr/h.10t					
c						
c	----- Fuel Rod : 11812 -----					
m161	92234.70c	9.9504E-06	92235.70c	1.0871E-03	92236.70c	1.2058E-05
	92238.70c	4.3398E-03	5010.70c	7.6331E-08	5011.70c	3.0724E-07
	1001.70c	5.0261E-02	1002.70c	5.7807E-06	6000.70c	1.1508E-03
	40090.70c	1.6472E-02	40091.70c	3.5921E-03	40092.70c	5.4907E-03
	40094.70c	5.5643E-03	40096.70c	8.9643E-04	68162.70c	3.3987E-07
	68164.70c	3.9085E-06	68166.70c	8.1592E-05	68167.70c	5.5665E-05
	68168.70c	6.5012E-05	68170.70c	3.6244E-05	72174.70c	1.3196E-09
	72176.70c	4.3380E-08	72177.70c	1.5340E-07	72178.70c	2.2498E-07
	72179.70c	1.1233E-07	72180.70c	2.8931E-07		
c	Total 8.9126E-02					
mt161	h/zr.10t zr/h.10t					
c						
c	----- Fuel Rod : 11813 -----					
m162	92234.70c	9.9525E-06	92235.70c	1.0889E-03	92236.70c	1.2061E-05
	92238.70c	4.3392E-03	5010.70c	7.6392E-08	5011.70c	3.0749E-07
	1001.70c	5.0321E-02	1002.70c	5.7876E-06	6000.70c	1.1158E-03
	40090.70c	1.6492E-02	40091.70c	3.5964E-03	40092.70c	5.4972E-03

Fundamental - FUND

NRAD-FUND-RESR-001
CRIT-REAC-COEF

```

40094.70c 5.5710E-03 40096.70c 8.9751E-04 68162.70c 3.4014E-07
68164.70c 3.9116E-06 68166.70c 8.1657E-05 68167.70c 5.5710E-05
68168.70c 6.5063E-05 68170.70c 3.6273E-05 72174.70c 1.3211E-09
72176.70c 4.3432E-08 72177.70c 1.5358E-07 72178.70c 2.2525E-07
72179.70c 1.1246E-07 72180.70c 2.8966E-07
c      Total 8.9191E-02
mt162  h/zr.10t  zr/h.10t
c
c ----- Fuel Rod : 11814 -----
m163  92234.70c 1.0073E-05 92235.70c 1.1029E-03 92236.70c 1.2207E-05
92238.70c 4.3911E-03 5010.70c 7.6537E-08 5011.70c 3.0807E-07
1001.70c 5.0199E-02 1002.70c 5.7736E-06 6000.70c 1.0818E-03
40090.70c 1.6452E-02 40091.70c 3.5877E-03 40092.70c 5.4839E-03
40094.70c 5.5575E-03 40096.70c 8.9533E-04 68162.70c 3.4078E-07
68164.70c 3.9190E-06 68166.70c 8.1812E-05 68167.70c 5.5815E-05
68168.70c 6.5187E-05 68170.70c 3.6342E-05 72174.70c 1.3179E-09
72176.70c 4.3327E-08 72177.70c 1.5321E-07 72178.70c 2.2471E-07
72179.70c 1.1219E-07 72180.70c 2.8896E-07
c      Total 8.9024E-02
mt163  h/zr.10t  zr/h.10t
c
c ----- Fuel Rod : 11815 -----
m164  92234.70c 1.0034E-05 92235.70c 1.1001E-03 92236.70c 1.2160E-05
92238.70c 4.3725E-03 5010.70c 7.6442E-08 5011.70c 3.0769E-07
1001.70c 5.0240E-02 1002.70c 5.7783E-06 6000.70c 9.7243E-04
40090.70c 1.6483E-02 40091.70c 3.5906E-03 40092.70c 5.4883E-03
40094.70c 5.5620E-03 40096.70c 8.9606E-04 68162.70c 3.2950E-07
68164.70c 3.7892E-06 68166.70c 7.9103E-05 68167.70c 5.3967E-05
68168.70c 6.3028E-05 68170.70c 3.5138E-05 72174.70c 1.3190E-09
72176.70c 4.3362E-08 72177.70c 1.5333E-07 72178.70c 2.2489E-07
72179.70c 1.1228E-07 72180.70c 2.8919E-07
c      Total 8.8952E-02
mt164  h/zr.10t  zr/h.10t
c
c --- Average UErZrH Fuel -----
c ----- 56-Rod-Average Fuel Rod Composition -----
m201  92234.70c 9.9283E-06 92235.70c 1.0836E-03 92236.70c 1.2032E-05
92238.70c 4.3312E-03 5010.70c 7.6273E-08 5011.70c 3.0701E-07
1001.70c 5.0614E-02 1002.70c 5.8213E-06 6000.70c 1.0781E-03
40090.70c 1.6483E-02 40091.70c 3.5945E-03 40092.70c 5.4942E-03
40094.70c 5.5679E-03 40096.70c 8.9701E-04 68162.70c 3.2516E-07
68164.70c 3.7393E-06 68166.70c 7.8061E-05 68167.70c 5.3256E-05
68168.70c 6.2198E-05 68170.70c 3.4676E-05 72174.70c 1.3204E-09
72176.70c 4.3408E-08 72177.70c 1.5350E-07 72178.70c 2.2513E-07
72179.70c 1.1240E-07 72180.70c 2.8950E-07
c      Total 8.9404E-02
mt201  h/zr.10t  zr/h.10t
c
c ----- 60-Rod-Average Fuel Rod Composition -----
m202  92234.70c 9.9323E-06 92235.70c 1.0844E-03 92236.70c 1.2036E-05
92238.70c 4.3326E-03 5010.70c 7.6277E-08 5011.70c 3.0702E-07
1001.70c 5.0608E-02 1002.70c 5.8206E-06 6000.70c 1.0781E-03
40090.70c 1.6481E-02 40091.70c 3.5940E-03 40092.70c 5.4936E-03
40094.70c 5.5672E-03 40096.70c 8.9691E-04 68162.70c 3.2517E-07
68164.70c 3.7395E-06 68166.70c 7.8064E-05 68167.70c 5.3258E-05
68168.70c 6.2200E-05 68170.70c 3.4677E-05 72174.70c 1.3203E-09
72176.70c 4.3403E-08 72177.70c 1.5348E-07 72178.70c 2.2510E-07
72179.70c 1.1239E-07 72180.70c 2.8947E-07
c      Total 8.9397E-02
mt202  h/zr.10t  zr/h.10t
c
c ----- 64-Rod-Average Fuel Rod Composition -----
m203  92234.70c 9.9363E-06 92235.70c 1.0851E-03 92236.70c 1.2041E-05
92238.70c 4.3340E-03 5010.70c 7.6286E-08 5011.70c 3.0706E-07
1001.70c 5.0608E-02 1002.70c 5.8206E-06 6000.70c 1.0783E-03
40090.70c 1.6481E-02 40091.70c 3.5940E-03 40092.70c 5.4935E-03
40094.70c 5.5672E-03 40096.70c 8.9690E-04 68162.70c 3.2521E-07
68164.70c 3.7399E-06 68166.70c 7.8073E-05 68167.70c 5.3265E-05
68168.70c 6.2208E-05 68170.70c 3.4681E-05 72174.70c 1.3202E-09
72176.70c 4.3403E-08 72177.70c 1.5348E-07 72178.70c 2.2510E-07
72179.70c 1.1239E-07 72180.70c 2.8946E-07
c      Total 8.9399E-02
mt203  h/zr.10t  zr/h.10t
c
c
c *** Control Cards *****

```

Fundamental - FUND

NRAD-FUND-RESR-001
CRIT-REAC-COEF

```
mode n
kcode 100000 1 50 1550
ksrc -1.9431 -1.9431 96.6 1.9431 1.9431 96.6
      -5.8293 5.8293 96.6 5.8293 -5.8293 96.6
      -9.7155 -9.7155 96.6 9.7155 9.7155 96.6
      -13.6017 13.6017 96.6 13.6017 -13.6017 96.6
      -13.6017 0.0 96.6 13.6017 0.0 96.6
      0.0 13.6017 96.6 0.0 -13.6017 96.6
print
kopts blocksize=10 kinetics=yes precursor=yes
c
```

Fundamental - FUND

NRAD-FUND-RESR-001
CRIT-REAC-COEF*MCNP5 Input Deck for the 60-fuel-element operational core configuration (Case 2):*

```

FRESH-CORE RELOAD OF THE NRAD REACTOR WITH U(20)-ER-ZR-H FUEL (DETAILED)
c
c John Darrell Bess - Idaho National Laboratory
c Last Updated: January 3, 2012
c
c Cell Cards *****
c --- Control Rod Positions -----
1415 0 202 -252 imp:n=1 u=1402 fill=1406 (0 0 38.1) $ Shim 2 Control Rod
2035 0 202 -252 imp:n=1 u=2004 fill=2006 (0 0 38.1) $ Shim 1 Control Rod
2815 0 202 -252 imp:n=1 u=2802 fill=2806 (0 0 20.4216) $ Reg Control Rod
c
c * Control Rods are fully inserted when the values in parenthesis are (0 0 0) *
c * Control Rods are fully withdrawn when the values are (0 0 38.1), which *
c * corresponds to 1000 units withdrawn *
c
c --- Assemblies -----
c ----- Position A-1 : Empty Position -----
101 1 9.9961E-02 -5 imp:n=1 u=100 $ Water Below Grid Plate
102 61 8.0867E-02 5 -7 imp:n=1 u=100 $ Empty Grid Plate Position
103 1 9.9961E-02 7 imp:n=1 u=100 $ Water Above Core
c
c ----- Position A-2 : Graphite Reflector -----
201 1 9.9961E-02 -5 imp:n=1 u=200 $ Water Below Grid Plate
203 63 6.9890E-02 5 -7 imp:n=1 u=200 $ Grid Plate With Adapter
204 44 7.6788E-02 7 -9 imp:n=1 u=200 $ Lower Adapter
205 41 7.8699E-02 (9 -10) (-9:303:354) (-9:303:355) (-9:305:351) (-306:10:356)
(-306:10:357) (331 -332 333 -334) (-335 -336 -337 -338)
imp:n=1 u=200 $ Graphite Block
206 42 6.0307E-02 307 -10 -356 imp:n=1 u=200 $ Top Screw NE
207 42 6.0307E-02 307 -10 -357 imp:n=1 u=200 $ Top Screw SW
208 1 9.9961E-02 306 -307 -356 imp:n=1 u=200 $ Water in NE Top Hole
209 1 9.9961E-02 306 -307 -357 imp:n=1 u=200 $ Water in SW Top Hole
210 42 6.0307E-02 9 -302 -352 imp:n=1 u=200 $ Bottom Dowel NE
211 42 6.0307E-02 9 -302 -353 imp:n=1 u=200 $ Bottom Dowel SW
212 42 6.0307E-02 9 -304 -351 imp:n=1 u=200 $ Tie Rod
213 1 9.9961E-02 (9 -303 352 -354):(302 -303 -354) imp:n=1 u=200 $ Water in NE Bottom Hole
214 1 9.9961E-02 (9 -303 353 -355):(302 -303 -355) imp:n=1 u=200 $ Water in SW Bottom Hole
215 1 9.9961E-02 (304 -305 -351) imp:n=1 u=200 $ Water in Tie Rod Hole
216 43 9.1820E-02 10 -309 imp:n=1 u=200 $ Upper Assembly
217 1 9.9961E-02 309 imp:n=1 u=200 $ Water Above Core
218 1 9.9961E-02 (9 -10) (-331:332:-333:334:335:336:337:338) imp:n=1 u=200 $ Water Around
Assembly
c
c ----- Position A-3 : North Beam Tube Support -----
301 1 9.9961E-02 -5 imp:n=1 u=300 $ Water Below Grid Plate
303 64 7.5685E-02 5 -7 imp:n=1 u=300 $ Grid Plate With Support
304 51 9.1752E-02 7 -401 imp:n=1 u=300 $ Beam Tube Support
305 1 9.9961E-02 401 imp:n=1 u=300 $ Water Above Support
c
c ----- Position A-4 : North Beam Tube Support -----
401 1 9.9961E-02 -5 imp:n=1 u=400 $ Water Below Grid Plate
403 64 7.5685E-02 5 -7 imp:n=1 u=400 $ Grid Plate With Support
404 51 9.1752E-02 7 -401 imp:n=1 u=400 $ Beam Tube Support
405 1 9.9961E-02 401 imp:n=1 u=400 $ Water Above Support
c
c ----- Position A-5 : Graphite Reflector -----
501 1 9.9961E-02 -5 imp:n=1 u=500 $ Water Below Grid Plate
503 63 6.9890E-02 5 -7 imp:n=1 u=500 $ Grid Plate With Adapter
504 44 7.6788E-02 7 -9 imp:n=1 u=500 $ Lower Adapter
505 41 7.8699E-02 (9 -10) (-9:303:354) (-9:303:355) (-9:305:351) (-306:10:356)
(-306:10:357) (331 -332 333 -334) (-335 -336 -337 -338)
imp:n=1 u=500 $ Graphite Block
506 42 6.0307E-02 307 -10 -356 imp:n=1 u=500 $ Top Screw NE
507 42 6.0307E-02 307 -10 -357 imp:n=1 u=500 $ Top Screw SW
508 1 9.9961E-02 306 -307 -356 imp:n=1 u=500 $ Water in NE Top Hole
509 1 9.9961E-02 306 -307 -357 imp:n=1 u=500 $ Water in SW Top Hole
510 42 6.0307E-02 9 -302 -352 imp:n=1 u=500 $ Bottom Dowel NE
511 42 6.0307E-02 9 -302 -353 imp:n=1 u=500 $ Bottom Dowel SW
512 42 6.0307E-02 9 -304 -351 imp:n=1 u=500 $ Tie Rod
513 1 9.9961E-02 (9 -303 352 -354):(302 -303 -354) imp:n=1 u=500 $ Water in NE Bottom Hole
514 1 9.9961E-02 (9 -303 353 -355):(302 -303 -355) imp:n=1 u=500 $ Water in SW Bottom Hole
515 1 9.9961E-02 (304 -305 -351) imp:n=1 u=500 $ Water in Tie Rod Hole
516 43 9.1820E-02 10 -309 imp:n=1 u=500 $ Upper Assembly

```

Fundamental - FUND

NRAD-FUND-RESR-001
CRIT-REAC-COEF

```

517 1 9.9961E-02 309 imp:n=1 u=500 $ Water Above Core
518 1 9.9961E-02 (9 -10) (-331:332:-333:334:335:336:337:338) imp:n=1 u=500 $ Water Around
Assembly
c
c ----- Position A-6 : Empty Position -----
601 1 9.9961E-02 -5 imp:n=1 u=600 $ Water Below Grid Plate
602 61 8.0867E-02 5 -7 imp:n=1 u=600 $ Empty Grid Plate Position
603 1 9.9961E-02 7 imp:n=1 u=600 $ Water Above Core
c
c ----- Position B-1 : Graphite Reflector -----
701 1 9.9961E-02 -5 imp:n=1 u=700 $ Water Below Grid Plate
703 63 6.9890E-02 5 -7 imp:n=1 u=700 $ Grid Plate With Adapter
704 44 7.6788E-02 7 -9 imp:n=1 u=700 $ Lower Adapter
705 41 7.8699E-02 (9 -10) (-9:303:354) (-9:303:355) (-9:305:351) (-306:10:356)
(-306:10:357) (331 -332 333 -334) (-335 -336 -337 -338)
imp:n=1 u=700 $ Graphite Block
706 42 6.0307E-02 307 -10 -356 imp:n=1 u=700 $ Top Screw NE
707 42 6.0307E-02 307 -10 -357 imp:n=1 u=700 $ Top Screw SW
708 1 9.9961E-02 306 -307 -356 imp:n=1 u=700 $ Water in NE Top Hole
709 1 9.9961E-02 306 -307 -357 imp:n=1 u=700 $ Water in SW Top Hole
710 42 6.0307E-02 9 -302 -352 imp:n=1 u=700 $ Bottom Dowel NE
711 42 6.0307E-02 9 -302 -353 imp:n=1 u=700 $ Bottom Dowel SW
712 42 6.0307E-02 9 -304 -351 imp:n=1 u=700 $ Tie Rod
713 1 9.9961E-02 (9 -303 352 -354):(302 -303 -354) imp:n=1 u=700 $ Water in NE Bottom Hole
714 1 9.9961E-02 (9 -303 353 -355):(302 -303 -355) imp:n=1 u=700 $ Water in SW Bottom Hole
715 1 9.9961E-02 (304 -305 -351) imp:n=1 u=700 $ Water in Tie Rod Hole
716 43 9.1820E-02 10 -309 imp:n=1 u=700 $ Upper Assembly
717 1 9.9961E-02 309 imp:n=1 u=700 $ Water Above Core
718 1 9.9961E-02 (9 -10) (-331:332:-333:334:335:336:337:338) imp:n=1 u=700 $ Water Around
Assembly
c
c ----- Position B-2 : 4-Rod Fuel Cluster -----
c ----- NW Fuel Rod : 11810 -----
801 14 8.7412E-02 (-103 -151):(102 -103 -156) imp:n=1 u=801 $ Bottom End Fitting
802 11 8.6735E-02 103 -104 -152 imp:n=1 u=801 $ Bottom Graphite Reflector
803 12 6.4196E-02 104 -105 -153 imp:n=1 u=801 $ Moly Poison Disc
804 13 4.3026E-02 105 -106 -154 imp:n=1 u=801 $ Zirconium Rod
870 2 5.0820E-05 105 -106 154 -159 imp:n=1 u=801 $ Zr/Fuel Gap
805 159 8.9626E-02 105 -106 159 -155 imp:n=1 u=801 $ Fuel Rod
806 11 8.6735E-02 106 -107 -152 imp:n=1 u=801 $ Top Graphite Reflector
807 2 5.0820E-05 (-103:104:152) (-104:105:153) (-105:106:155)
(-106:107:152) (103 -108 -156) imp:n=1 u=801 $ Air Gap
808 14 8.7412E-02 102 -109 156 -157 imp:n=1 u=801 $ Cladding
809 14 8.7412E-02 (108 -158):(108 -109 -156) imp:n=1 u=801 $ Top End Fitting
810 1 9.9961E-02 157:(-102 151):(109 158) imp:n=1 u=801 $ Water
c
c ----- NE Fuel Rod : 11811 -----
811 14 8.7412E-02 (-103 -151):(102 -103 -156) imp:n=1 u=802 $ Bottom End Fitting
812 11 8.6735E-02 103 -104 -152 imp:n=1 u=802 $ Bottom Graphite Reflector
813 12 6.4196E-02 104 -105 -153 imp:n=1 u=802 $ Moly Poison Disc
814 13 4.3026E-02 105 -106 -154 imp:n=1 u=802 $ Zirconium Rod
871 2 5.0820E-05 105 -106 154 -159 imp:n=1 u=802 $ Zr/Fuel Gap
815 160 9.0182E-02 105 -106 159 -155 imp:n=1 u=802 $ Fuel Rod
816 11 8.6735E-02 106 -107 -152 imp:n=1 u=802 $ Top Graphite Reflector
817 2 5.0820E-05 (-103:104:152) (-104:105:153) (-105:106:155)
(-106:107:152) (103 -108 -156) imp:n=1 u=802 $ Air Gap
818 14 8.7412E-02 102 -109 156 -157 imp:n=1 u=802 $ Cladding
819 14 8.7412E-02 (108 -158):(108 -109 -156) imp:n=1 u=802 $ Top End Fitting
820 1 9.9961E-02 157:(-102 151):(109 158) imp:n=1 u=802 $ Water
c
c ----- SW Fuel Rod : 11809 -----
821 14 8.7412E-02 (-103 -151):(102 -103 -156) imp:n=1 u=803 $ Bottom End Fitting
822 11 8.6735E-02 103 -104 -152 imp:n=1 u=803 $ Bottom Graphite Reflector
823 12 6.4196E-02 104 -105 -153 imp:n=1 u=803 $ Moly Poison Disc
824 13 4.3026E-02 105 -106 -154 imp:n=1 u=803 $ Zirconium Rod
872 2 5.0820E-05 105 -106 154 -159 imp:n=1 u=803 $ Zr/Fuel Gap
825 158 8.9820E-02 105 -106 159 -155 imp:n=1 u=803 $ Fuel Rod
826 11 8.6735E-02 106 -107 -152 imp:n=1 u=803 $ Top Graphite Reflector
827 2 5.0820E-05 (-103:104:152) (-104:105:153) (-105:106:155)
(-106:107:152) (103 -108 -156) imp:n=1 u=803 $ Air Gap
828 14 8.7412E-02 102 -109 156 -157 imp:n=1 u=803 $ Cladding
829 14 8.7412E-02 (108 -158):(108 -109 -156) imp:n=1 u=803 $ Top End Fitting
830 1 9.9961E-02 157:(-102 151):(109 158) imp:n=1 u=803 $ Water
c
c ----- SE Fuel Rod : 11808 -----
831 14 8.7412E-02 (-103 -151):(102 -103 -156) imp:n=1 u=804 $ Bottom End Fitting

```

Fundamental - FUND

NRAD-FUND-RESR-001
CRIT-REAC-COEF

```

832 11 8.6735E-02 103 -104 -152 imp:n=1 u=804 $ Bottom Graphite Reflector
833 12 6.4196E-02 104 -105 -153 imp:n=1 u=804 $ Moly Poison Disc
834 13 4.3026E-02 105 -106 -154 imp:n=1 u=804 $ Zirconium Rod
873 2 5.0820E-05 105 -106 154 -159 imp:n=1 u=804 $ Zr/Fuel Gap
835 157 8.9348E-02 105 -106 159 -155 imp:n=1 u=804 $ Fuel Rod
836 11 8.6735E-02 106 -107 -152 imp:n=1 u=804 $ Top Graphite Reflector
837 2 5.0820E-05 (-103:104:152) (-104:105:153) (-105:106:155)
      (-106:107:152) (103 -108 -156) imp:n=1 u=804 $ Air Gap
838 14 8.7412E-02 102 -109 156 -157 imp:n=1 u=804 $ Cladding
839 14 8.7412E-02 (108 -158):(108 -109 -156) imp:n=1 u=804 $ Top End Fitting
840 1 9.9961E-02 157:(-102 151):(109 158) imp:n=1 u=804 $ Water
c
c ----- Fuel Assembly -----
841 1 9.9961E-02 -5 imp:n=1 u=800 $ Water Below Grid Plate
843 62 7.4744E-02 5 -7 imp:n=1 u=800 $ Grid Plate With Adapter
844 33 7.7699E-02 7 -9 imp:n=1 u=800 $ Lower Adapter
845 1 9.9961E-02 -132 131 -134 133 imp:n=1 u=805 lat=1 fill=-1:2 -1:2 0:0 $ Fuel Assemblies
      805 805 805 805
      805 803 804 805
      805 801 802 805
      805 805 805 805
846 0 9 -10 imp:n=1 u=800 fill=805 (-1.9431 -1.9431 0) $ Fuel Bundle
847 31 9.3070E-02 10 -12 imp:n=1 u=800 $ Upper Assembly
848 1 9.9961E-02 12 imp:n=1 u=800 $ Water Above Core
c
c ----- Position B-3 : 4-Rod Fuel Cluster -----
c ----- NW Fuel Rod : 11776 -----
901 14 8.7412E-02 (-103 -151):(102 -103 -156) imp:n=1 u=901 $ Bottom End Fitting
902 11 8.6735E-02 103 -104 -152 imp:n=1 u=901 $ Bottom Graphite Reflector
903 12 6.4196E-02 104 -105 -153 imp:n=1 u=901 $ Moly Poison Disc
904 13 4.3026E-02 105 -106 -154 imp:n=1 u=901 $ Zirconium Rod
970 2 5.0820E-05 105 -106 154 -159 imp:n=1 u=901 $ Zr/Fuel Gap
905 125 8.9953E-02 105 -106 159 -155 imp:n=1 u=901 $ Fuel Rod
906 11 8.6735E-02 106 -107 -152 imp:n=1 u=901 $ Top Graphite Reflector
907 2 5.0820E-05 (-103:104:152) (-104:105:153) (-105:106:155)
      (-106:107:152) (103 -108 -156) imp:n=1 u=901 $ Air Gap
908 14 8.7412E-02 102 -109 156 -157 imp:n=1 u=901 $ Cladding
909 14 8.7412E-02 (108 -158):(108 -109 -156) imp:n=1 u=901 $ Top End Fitting
910 1 9.9961E-02 157:(-102 151):(109 158) imp:n=1 u=901 $ Water
c
c ----- NE Fuel Rod : 11777 -----
911 14 8.7412E-02 (-103 -151):(102 -103 -156) imp:n=1 u=902 $ Bottom End Fitting
912 11 8.6735E-02 103 -104 -152 imp:n=1 u=902 $ Bottom Graphite Reflector
913 12 6.4196E-02 104 -105 -153 imp:n=1 u=902 $ Moly Poison Disc
914 13 4.3026E-02 105 -106 -154 imp:n=1 u=902 $ Zirconium Rod
971 2 5.0820E-05 105 -106 154 -159 imp:n=1 u=902 $ Zr/Fuel Gap
915 126 8.9487E-02 105 -106 159 -155 imp:n=1 u=902 $ Fuel Rod
916 11 8.6735E-02 106 -107 -152 imp:n=1 u=902 $ Top Graphite Reflector
917 2 5.0820E-05 (-103:104:152) (-104:105:153) (-105:106:155)
      (-106:107:152) (103 -108 -156) imp:n=1 u=902 $ Air Gap
918 14 8.7412E-02 102 -109 156 -157 imp:n=1 u=902 $ Cladding
919 14 8.7412E-02 (108 -158):(108 -109 -156) imp:n=1 u=902 $ Top End Fitting
920 1 9.9961E-02 157:(-102 151):(109 158) imp:n=1 u=902 $ Water
c
c ----- SW Fuel Rod : 11778 -----
921 14 8.7412E-02 (-103 -151):(102 -103 -156) imp:n=1 u=903 $ Bottom End Fitting
922 11 8.6735E-02 103 -104 -152 imp:n=1 u=903 $ Bottom Graphite Reflector
923 12 6.4196E-02 104 -105 -153 imp:n=1 u=903 $ Moly Poison Disc
924 13 4.3026E-02 105 -106 -154 imp:n=1 u=903 $ Zirconium Rod
972 2 5.0820E-05 105 -106 154 -159 imp:n=1 u=903 $ Zr/Fuel Gap
925 127 8.9490E-02 105 -106 159 -155 imp:n=1 u=903 $ Fuel Rod
926 11 8.6735E-02 106 -107 -152 imp:n=1 u=903 $ Top Graphite Reflector
927 2 5.0820E-05 (-103:104:152) (-104:105:153) (-105:106:155)
      (-106:107:152) (103 -108 -156) imp:n=1 u=903 $ Air Gap
928 14 8.7412E-02 102 -109 156 -157 imp:n=1 u=903 $ Cladding
929 14 8.7412E-02 (108 -158):(108 -109 -156) imp:n=1 u=903 $ Top End Fitting
930 1 9.9961E-02 157:(-102 151):(109 158) imp:n=1 u=903 $ Water
c
c ----- SE Fuel Rod : 11779 -----
931 14 8.7412E-02 (-103 -151):(102 -103 -156) imp:n=1 u=904 $ Bottom End Fitting
932 11 8.6735E-02 103 -104 -152 imp:n=1 u=904 $ Bottom Graphite Reflector
933 12 6.4196E-02 104 -105 -153 imp:n=1 u=904 $ Moly Poison Disc
934 13 4.3026E-02 105 -106 -154 imp:n=1 u=904 $ Zirconium Rod
973 2 5.0820E-05 105 -106 154 -159 imp:n=1 u=904 $ Zr/Fuel Gap
935 128 8.9458E-02 105 -106 159 -155 imp:n=1 u=904 $ Fuel Rod
936 11 8.6735E-02 106 -107 -152 imp:n=1 u=904 $ Top Graphite Reflector

```

Fundamental - FUND

NRAD-FUND-RESR-001
CRIT-REAC-COEF

```

937  2 5.0820E-05 (-103:104:152) (-104:105:153) (-105:106:155)
      (-106:107:152) (103 -108 -156) imp:n=1 u=904 $ Air Gap
938 14 8.7412E-02 102 -109 156 -157 imp:n=1 u=904 $ Cladding
939 14 8.7412E-02 (108 -158):(108 -109 -156) imp:n=1 u=904 $ Top End Fitting
940  1 9.9961E-02 157:(-102 151):(109 158) imp:n=1 u=904 $ Water
c
c ----- Fuel Assembly -----
941  1 9.9961E-02 -5 imp:n=1 u=900 $ Water Below Grid Plate
943 62 7.4744E-02 5 -7 imp:n=1 u=900 $ Grid Plate With Adapter
944 33 7.7699E-02 7 -9 imp:n=1 u=900 $ Lower Adapter
945  1 9.9961E-02 -132 131 -134 133 imp:n=1 u=905 lat=1 fill=-1:2 -1:2 0:0 $ Fuel Assemblies
      905 905 905 905
      905 903 904 905
      905 901 902 905
      905 905 905 905
946  0 9 -10 imp:n=1 u=900 fill=905 (-1.9431 -1.9431 0) $ Fuel Bundle
947 31 9.3070E-02 10 -12 imp:n=1 u=900 $ Upper Assembly
948  1 9.9961E-02 12 imp:n=1 u=900 $ Water Above Core
c
c ----- Position B-4 : 4-Rod Fuel Cluster -----
c ----- NW Fuel Rod : 11785 -----
1001 14 8.7412E-02 (-103 -151):(102 -103 -156) imp:n=1 u=1001 $ Bottom End Fitting
1002 11 8.6735E-02 103 -104 -152 imp:n=1 u=1001 $ Bottom Graphite Reflector
1003 12 6.4196E-02 104 -105 -153 imp:n=1 u=1001 $ Moly Poison Disc
1004 13 4.3026E-02 105 -106 -154 imp:n=1 u=1001 $ Zirconium Rod
1070  2 5.0820E-05 105 -106 154 -159 imp:n=1 u=1001 $ Zr/Fuel Gap
1005 134 8.9160E-02 105 -106 159 -155 imp:n=1 u=1001 $ Fuel Rod
1006 11 8.6735E-02 106 -107 -152 imp:n=1 u=1001 $ Top Graphite Reflector
1007  2 5.0820E-05 (-103:104:152) (-104:105:153) (-105:106:155)
      (-106:107:152) (103 -108 -156) imp:n=1 u=1001 $ Air Gap
1008 14 8.7412E-02 102 -109 156 -157 imp:n=1 u=1001 $ Cladding
1009 14 8.7412E-02 (108 -158):(108 -109 -156) imp:n=1 u=1001 $ Top End Fitting
1010  1 9.9961E-02 157:(-102 151):(109 158) imp:n=1 u=1001 $ Water
c
c ----- NE Fuel Rod : 11787 -----
1011 14 8.7412E-02 (-103 -151):(102 -103 -156) imp:n=1 u=1002 $ Bottom End Fitting
1012 11 8.6735E-02 103 -104 -152 imp:n=1 u=1002 $ Bottom Graphite Reflector
1013 12 6.4196E-02 104 -105 -153 imp:n=1 u=1002 $ Moly Poison Disc
1014 13 4.3026E-02 105 -106 -154 imp:n=1 u=1002 $ Zirconium Rod
1071  2 5.0820E-05 105 -106 154 -159 imp:n=1 u=1002 $ Zr/Fuel Gap
1015 136 8.8980E-02 105 -106 159 -155 imp:n=1 u=1002 $ Fuel Rod
1016 11 8.6735E-02 106 -107 -152 imp:n=1 u=1002 $ Top Graphite Reflector
1017  2 5.0820E-05 (-103:104:152) (-104:105:153) (-105:106:155)
      (-106:107:152) (103 -108 -156) imp:n=1 u=1002 $ Air Gap
1018 14 8.7412E-02 102 -109 156 -157 imp:n=1 u=1002 $ Cladding
1019 14 8.7412E-02 (108 -158):(108 -109 -156) imp:n=1 u=1002 $ Top End Fitting
1020  1 9.9961E-02 157:(-102 151):(109 158) imp:n=1 u=1002 $ Water
c
c ----- SW Fuel Rod : 11784 -----
1021 14 8.7412E-02 (-103 -151):(102 -103 -156) imp:n=1 u=1003 $ Bottom End Fitting
1022 11 8.6735E-02 103 -104 -152 imp:n=1 u=1003 $ Bottom Graphite Reflector
1023 12 6.4196E-02 104 -105 -153 imp:n=1 u=1003 $ Moly Poison Disc
1024 13 4.3026E-02 105 -106 -154 imp:n=1 u=1003 $ Zirconium Rod
1072  2 5.0820E-05 105 -106 154 -159 imp:n=1 u=1003 $ Zr/Fuel Gap
1025 133 8.9174E-02 105 -106 159 -155 imp:n=1 u=1003 $ Fuel Rod
1026 11 8.6735E-02 106 -107 -152 imp:n=1 u=1003 $ Top Graphite Reflector
1027  2 5.0820E-05 (-103:104:152) (-104:105:153) (-105:106:155)
      (-106:107:152) (103 -108 -156) imp:n=1 u=1003 $ Air Gap
1028 14 8.7412E-02 102 -109 156 -157 imp:n=1 u=1003 $ Cladding
1029 14 8.7412E-02 (108 -158):(108 -109 -156) imp:n=1 u=1003 $ Top End Fitting
1030  1 9.9961E-02 157:(-102 151):(109 158) imp:n=1 u=1003 $ Water
c
c ----- SE Fuel Rod : 11786 -----
1031 14 8.7412E-02 (-103 -151):(102 -103 -156) imp:n=1 u=1004 $ Bottom End Fitting
1032 11 8.6735E-02 103 -104 -152 imp:n=1 u=1004 $ Bottom Graphite Reflector
1033 12 6.4196E-02 104 -105 -153 imp:n=1 u=1004 $ Moly Poison Disc
1034 13 4.3026E-02 105 -106 -154 imp:n=1 u=1004 $ Zirconium Rod
1073  2 5.0820E-05 105 -106 154 -159 imp:n=1 u=1004 $ Zr/Fuel Gap
1035 135 8.9542E-02 105 -106 159 -155 imp:n=1 u=1004 $ Fuel Rod
1036 11 8.6735E-02 106 -107 -152 imp:n=1 u=1004 $ Top Graphite Reflector
1037  2 5.0820E-05 (-103:104:152) (-104:105:153) (-105:106:155)
      (-106:107:152) (103 -108 -156) imp:n=1 u=1004 $ Air Gap
1038 14 8.7412E-02 102 -109 156 -157 imp:n=1 u=1004 $ Cladding
1039 14 8.7412E-02 (108 -158):(108 -109 -156) imp:n=1 u=1004 $ Top End Fitting
1040  1 9.9961E-02 157:(-102 151):(109 158) imp:n=1 u=1004 $ Water
c

```

Fundamental - FUND

NRAD-FUND-RESR-001
CRIT-REAC-COEF

```

c ----- Fuel Assembly -----
1041 1 9.9961E-02 -5 imp:n=1 u=1000 $ Water Below Grid Plate
1043 62 7.4744E-02 5 -7 imp:n=1 u=1000 $ Grid Plate With Adapter
1044 33 7.7699E-02 7 -9 imp:n=1 u=1000 $ Lower Adapter
1045 1 9.9961E-02 -132 131 -134 133 imp:n=1 u=1005 lat=1 fill=-1:2 -1:2 0:0 $ Fuel Assemblies
      1005 1005 1005 1005
      1005 1003 1004 1005
      1005 1001 1002 1005
      1005 1005 1005 1005
1046 0 9 -10 imp:n=1 u=1000 fill=1005 (-1.9431 -1.9431 0) $ Fuel Bundle
1047 31 9.3070E-02 10 -12 imp:n=1 u=1000 $ Upper Assembly
1048 1 9.9961E-02 12 imp:n=1 u=1000 $ Water Above Core
c
c ----- Position B-5 : 4-Rod Fuel Cluster -----
c ----- NW Fuel Rod : 11800 -----
1101 14 8.7412E-02 (-103 -151):(102 -103 -156) imp:n=1 u=1101 $ Bottom End Fitting
1102 11 8.6735E-02 103 -104 -152 imp:n=1 u=1101 $ Bottom Graphite Reflector
1103 12 6.4196E-02 104 -105 -153 imp:n=1 u=1101 $ Moly Poison Disc
1104 13 4.3026E-02 105 -106 -154 imp:n=1 u=1101 $ Zirconium Rod
1170 2 5.0820E-05 105 -106 154 -159 imp:n=1 u=1101 $ Zr/Fuel Gap
1105 149 8.9216E-02 105 -106 159 -155 imp:n=1 u=1101 $ Fuel Rod
1106 11 8.6735E-02 106 -107 -152 imp:n=1 u=1101 $ Top Graphite Reflector
1107 2 5.0820E-05 (-103:104:152) (-104:105:153) (-105:106:155)
      (-106:107:152) (103 -108 -156) imp:n=1 u=1101 $ Air Gap
1108 14 8.7412E-02 102 -109 156 -157 imp:n=1 u=1101 $ Cladding
1109 14 8.7412E-02 (108 -158):(108 -109 -156) imp:n=1 u=1101 $ Top End Fitting
1110 1 9.9961E-02 157:(-102 151):(109 158) imp:n=1 u=1101 $ Water
c
c ----- NE Fuel Rod : 11802 -----
1111 14 8.7412E-02 (-103 -151):(102 -103 -156) imp:n=1 u=1102 $ Bottom End Fitting
1112 11 8.6735E-02 103 -104 -152 imp:n=1 u=1102 $ Bottom Graphite Reflector
1113 12 6.4196E-02 104 -105 -153 imp:n=1 u=1102 $ Moly Poison Disc
1114 13 4.3026E-02 105 -106 -154 imp:n=1 u=1102 $ Zirconium Rod
1171 2 5.0820E-05 105 -106 154 -159 imp:n=1 u=1102 $ Zr/Fuel Gap
1115 151 8.8842E-02 105 -106 159 -155 imp:n=1 u=1102 $ Fuel Rod
1116 11 8.6735E-02 106 -107 -152 imp:n=1 u=1102 $ Top Graphite Reflector
1117 2 5.0820E-05 (-103:104:152) (-104:105:153) (-105:106:155)
      (-106:107:152) (103 -108 -156) imp:n=1 u=1102 $ Air Gap
1118 14 8.7412E-02 102 -109 156 -157 imp:n=1 u=1102 $ Cladding
1119 14 8.7412E-02 (108 -158):(108 -109 -156) imp:n=1 u=1102 $ Top End Fitting
1120 1 9.9961E-02 157:(-102 151):(109 158) imp:n=1 u=1102 $ Water
c
c ----- SW Fuel Rod : 11801 -----
1121 14 8.7412E-02 (-103 -151):(102 -103 -156) imp:n=1 u=1103 $ Bottom End Fitting
1122 11 8.6735E-02 103 -104 -152 imp:n=1 u=1103 $ Bottom Graphite Reflector
1123 12 6.4196E-02 104 -105 -153 imp:n=1 u=1103 $ Moly Poison Disc
1124 13 4.3026E-02 105 -106 -154 imp:n=1 u=1103 $ Zirconium Rod
1172 2 5.0820E-05 105 -106 154 -159 imp:n=1 u=1103 $ Zr/Fuel Gap
1125 150 8.9361E-02 105 -106 159 -155 imp:n=1 u=1103 $ Fuel Rod
1126 11 8.6735E-02 106 -107 -152 imp:n=1 u=1103 $ Top Graphite Reflector
1127 2 5.0820E-05 (-103:104:152) (-104:105:153) (-105:106:155)
      (-106:107:152) (103 -108 -156) imp:n=1 u=1103 $ Air Gap
1128 14 8.7412E-02 102 -109 156 -157 imp:n=1 u=1103 $ Cladding
1129 14 8.7412E-02 (108 -158):(108 -109 -156) imp:n=1 u=1103 $ Top End Fitting
1130 1 9.9961E-02 157:(-102 151):(109 158) imp:n=1 u=1103 $ Water
c
c ----- SE Fuel Rod : 11803 -----
1131 14 8.7412E-02 (-103 -151):(102 -103 -156) imp:n=1 u=1104 $ Bottom End Fitting
1132 11 8.6735E-02 103 -104 -152 imp:n=1 u=1104 $ Bottom Graphite Reflector
1133 12 6.4196E-02 104 -105 -153 imp:n=1 u=1104 $ Moly Poison Disc
1134 13 4.3026E-02 105 -106 -154 imp:n=1 u=1104 $ Zirconium Rod
1173 2 5.0820E-05 105 -106 154 -159 imp:n=1 u=1104 $ Zr/Fuel Gap
1135 152 8.9101E-02 105 -106 159 -155 imp:n=1 u=1104 $ Fuel Rod
1136 11 8.6735E-02 106 -107 -152 imp:n=1 u=1104 $ Top Graphite Reflector
1137 2 5.0820E-05 (-103:104:152) (-104:105:153) (-105:106:155)
      (-106:107:152) (103 -108 -156) imp:n=1 u=1104 $ Air Gap
1138 14 8.7412E-02 102 -109 156 -157 imp:n=1 u=1104 $ Cladding
1139 14 8.7412E-02 (108 -158):(108 -109 -156) imp:n=1 u=1104 $ Top End Fitting
1140 1 9.9961E-02 157:(-102 151):(109 158) imp:n=1 u=1104 $ Water
c
c ----- Fuel Assembly -----
1141 1 9.9961E-02 -5 imp:n=1 u=1100 $ Water Below Grid Plate
1143 62 7.4744E-02 5 -7 imp:n=1 u=1100 $ Grid Plate With Adapter
1144 33 7.7699E-02 7 -9 imp:n=1 u=1100 $ Lower Adapter
1145 1 9.9961E-02 -132 131 -134 133 imp:n=1 u=1105 lat=1 fill=-1:2 -1:2 0:0 $ Fuel Assemblies
      1105 1105 1105 1105

```

Fundamental - FUND

NRAD-FUND-RESR-001
CRIT-REAC-COEF

```

1105 1103 1104 1105
1105 1101 1102 1105
1105 1105 1105 1105
1146 0 9 -10 imp:n=1 u=1100 fill=1105 (-1.9431 -1.9431 0) $ Fuel Bundle
1147 31 9.3070E-02 10 -12 imp:n=1 u=1100 $ Upper Assembly
1148 1 9.9961E-02 12 imp:n=1 u=1100 $ Water Above Core
c
c ----- Position B-6 : Graphite Reflector -----
1201 1 9.9961E-02 -5 imp:n=1 u=1200 $ Water Below Grid Plate
1203 63 6.9890E-02 5 -7 imp:n=1 u=1200 $ Grid Plate With Adapter
1204 44 7.6788E-02 7 -9 imp:n=1 u=1200 $ Lower Adapter
1205 41 7.8699E-02 (9 -10) (-9:303:354) (-9:303:355) (-9:305:351) (-306:10:356)
(-306:10:357) (331 -332 333 -334) (-335 -336 -337 -338)
imp:n=1 u=1200 $ Graphite Block
1206 42 6.0307E-02 307 -10 -356 imp:n=1 u=1200 $ Top Screw NE
1207 42 6.0307E-02 307 -10 -357 imp:n=1 u=1200 $ Top Screw SW
1208 1 9.9961E-02 306 -307 -356 imp:n=1 u=1200 $ Water in NE Top Hole
1209 1 9.9961E-02 306 -307 -357 imp:n=1 u=1200 $ Water in SW Top Hole
1210 42 6.0307E-02 9 -302 -352 imp:n=1 u=1200 $ Bottom Dowel NE
1211 42 6.0307E-02 9 -302 -353 imp:n=1 u=1200 $ Bottom Dowel SW
1212 42 6.0307E-02 9 -304 -351 imp:n=1 u=1200 $ Tie Rod
1213 1 9.9961E-02 (9 -303 352 -354):(302 -303 -354) imp:n=1 u=1200 $ Water in NE Bottom Hole
1214 1 9.9961E-02 (9 -303 353 -355):(302 -303 -355) imp:n=1 u=1200 $ Water in SW Bottom Hole
1215 1 9.9961E-02 (304 -305 -351) imp:n=1 u=1200 $ Water in Tie Rod Hole
1216 43 9.1820E-02 10 -309 imp:n=1 u=1200 $ Upper Assembly
1217 1 9.9961E-02 309 imp:n=1 u=1200 $ Water Above Core
1218 1 9.9961E-02 (9 -10) (-331:332:-333:334:335:336:337:338) imp:n=1 u=1200 $ Water Around
Assembly
c
c ----- Position C-1 : Graphite Reflector -----
1301 1 9.9961E-02 -5 imp:n=1 u=1300 $ Water Below Grid Plate
1303 63 6.9890E-02 5 -7 imp:n=1 u=1300 $ Grid Plate With Adapter
1304 44 7.6788E-02 7 -9 imp:n=1 u=1300 $ Lower Adapter
1305 41 7.8699E-02 (9 -10) (-9:303:354) (-9:303:355) (-9:305:351) (-306:10:356)
(-306:10:357) (331 -332 333 -334) (-335 -336 -337 -338)
imp:n=1 u=1300 $ Graphite Block
1306 42 6.0307E-02 307 -10 -356 imp:n=1 u=1300 $ Top Screw NE
1307 42 6.0307E-02 307 -10 -357 imp:n=1 u=1300 $ Top Screw SW
1308 1 9.9961E-02 306 -307 -356 imp:n=1 u=1300 $ Water in NE Top Hole
1309 1 9.9961E-02 306 -307 -357 imp:n=1 u=1300 $ Water in SW Top Hole
1310 42 6.0307E-02 9 -302 -352 imp:n=1 u=1300 $ Bottom Dowel NE
1311 42 6.0307E-02 9 -302 -353 imp:n=1 u=1300 $ Bottom Dowel SW
1312 42 6.0307E-02 9 -304 -351 imp:n=1 u=1300 $ Tie Rod
1313 1 9.9961E-02 (9 -303 352 -354):(302 -303 -354) imp:n=1 u=1300 $ Water in NE Bottom Hole
1314 1 9.9961E-02 (9 -303 353 -355):(302 -303 -355) imp:n=1 u=1300 $ Water in SW Bottom Hole
1315 1 9.9961E-02 (304 -305 -351) imp:n=1 u=1300 $ Water in Tie Rod Hole
1316 43 9.1820E-02 10 -309 imp:n=1 u=1300 $ Upper Assembly
1317 1 9.9961E-02 309 imp:n=1 u=1300 $ Water Above Core
1318 1 9.9961E-02 (9 -10) (-331:332:-333:334:335:336:337:338) imp:n=1 u=1300 $ Water Around
Assembly
c
c ----- Position C-2 : Shim Rod 2 Control Cluster -----
c ----- NW Fuel Rod : 11752 -----
1401 14 8.7412E-02 (-103 -151):(102 -103 -156) imp:n=1 u=1401 $ Bottom End Fitting
1402 11 8.6735E-02 103 -104 -152 imp:n=1 u=1401 $ Bottom Graphite Reflector
1403 12 6.4196E-02 104 -105 -153 imp:n=1 u=1401 $ Moly Poison Disc
1404 13 4.3026E-02 105 -106 -154 imp:n=1 u=1401 $ Zirconium Rod
1470 2 5.0820E-05 105 -106 154 -159 imp:n=1 u=1401 $ Zr/Fuel Gap
1405 101 8.9406E-02 105 -106 159 -155 imp:n=1 u=1401 $ Fuel Rod
1406 11 8.6735E-02 106 -107 -152 imp:n=1 u=1401 $ Top Graphite Reflector
1407 2 5.0820E-05 (-103:104:152) (-104:105:153) (-105:106:155)
(-106:107:152) (103 -108 -156) imp:n=1 u=1401 $ Air Gap
1408 14 8.7412E-02 102 -109 156 -157 imp:n=1 u=1401 $ Cladding
1409 14 8.7412E-02 (108 -158):(108 -109 -156) imp:n=1 u=1401 $ Top End Fitting
1410 1 9.9961E-02 157:(-102 151):(109 158) imp:n=1 u=1401 $ Water
c
c ----- NE Control Rod : Shim 2 -----
1411 14 8.7412E-02 -201 -251 imp:n=1 u=1402 $ Bottom End Fitting
1412 23 6.7723E-02 201 -202 -253 imp:n=1 u=1402 $ Guide Tube Bottom
1413 25 6.1351E-02 202 -203 252 -253 imp:n=1 u=1402 $ Guide Tube
1414 1 9.9961E-02 (-201 251):253:(203 252) imp:n=1 u=1402 $ Water Outside Guide Tube
c
1450 22 5.9939E-02 231 -232 -275 imp:n=1 u=1406 $ Bottom End Fitting
1451 21 1.3514E-01 232 -233 -271 imp:n=1 u=1406 $ Absorber
1452 22 5.9939E-02 233 -234 272 -271 imp:n=1 u=1406 $ Spacer Disc
1453 22 5.9939E-02 234 -235 273 -274 imp:n=1 u=1406 $ Spacer Tube

```

Fundamental - FUND

NRAD-FUND-RESR-001
CRIT-REAC-COEF

```

1454 0 (232 -234 271 -275):(233 -234 -272):(234 -235 -273):(234 -235 274 -275)
      imp:n=1 u=1406 $ Void Space
1455 22 5.9939E-02 (235 -236 -275):(236 -237 -277) imp:n=1 u=1406 $ Top End Fitting
1456 22 5.9939E-02 231 -236 275 -276 imp:n=1 u=1406 $ Cladding
1457 24 6.8709E-02 237 -238 -278 imp:n=1 u=1406 $ Attachment Interface
1458 2 5.0820E-05 238 -239 -279 imp:n=1 u=1406 $ Inside Extension Rod
1459 22 5.9939E-02 238 -239 279 -280 imp:n=1 u=1406 $ Extension Rod
1460 1 9.9961E-02 (-231 -276):(276):(236 278):(238 280):(236 -237 277):(239)
      imp:n=1 u=1406 $ Water around Control Rod
c
c ----- SW Fuel Rod : 11753 ----- ---
1421 14 8.7412E-02 (-103 -151):(102 -103 -156) imp:n=1 u=1403 $ Bottom End Fitting
1422 11 8.6735E-02 103 -104 -152 imp:n=1 u=1403 $ Bottom Graphite Reflector
1423 12 6.4196E-02 104 -105 -153 imp:n=1 u=1403 $ Moly Poison Disc
1424 13 4.3026E-02 105 -106 -154 imp:n=1 u=1403 $ Zirconium Rod
1472 2 5.0820E-05 105 -106 154 -159 imp:n=1 u=1403 $ Zr/Fuel Gap
1425 102 8.9321E-02 105 -106 159 -155 imp:n=1 u=1403 $ Fuel Rod
1426 11 8.6735E-02 106 -107 -152 imp:n=1 u=1403 $ Top Graphite Reflector
1427 2 5.0820E-05 (-103:104:152) (-104:105:153) (-105:106:155)
      (-106:107:152) (103 -108 -156) imp:n=1 u=1403 $ Air Gap
1428 14 8.7412E-02 102 -109 156 -157 imp:n=1 u=1403 $ Cladding
1429 14 8.7412E-02 (108 -158):(108 -109 -156) imp:n=1 u=1403 $ Top End Fitting
1430 1 9.9961E-02 157:(-102 151):(109 158) imp:n=1 u=1403 $ Water
c
c ----- SE Fuel Rod : 11754 ----- ---
1431 14 8.7412E-02 (-103 -151):(102 -103 -156) imp:n=1 u=1404 $ Bottom End Fitting
1432 11 8.6735E-02 103 -104 -152 imp:n=1 u=1404 $ Bottom Graphite Reflector
1433 12 6.4196E-02 104 -105 -153 imp:n=1 u=1404 $ Moly Poison Disc
1434 13 4.3026E-02 105 -106 -154 imp:n=1 u=1404 $ Zirconium Rod
1473 2 5.0820E-05 105 -106 154 -159 imp:n=1 u=1404 $ Zr/Fuel Gap
1435 103 8.9350E-02 105 -106 159 -155 imp:n=1 u=1404 $ Fuel Rod
1436 11 8.6735E-02 106 -107 -152 imp:n=1 u=1404 $ Top Graphite Reflector
1437 2 5.0820E-05 (-103:104:152) (-104:105:153) (-105:106:155)
      (-106:107:152) (103 -108 -156) imp:n=1 u=1404 $ Air Gap
1438 14 8.7412E-02 102 -109 156 -157 imp:n=1 u=1404 $ Cladding
1439 14 8.7412E-02 (108 -158):(108 -109 -156) imp:n=1 u=1404 $ Top End Fitting
1440 1 9.9961E-02 157:(-102 151):(109 158) imp:n=1 u=1404 $ Water
c
c ----- Fuel Assembly -----
1441 1 9.9961E-02 -5 imp:n=1 u=1400 $ Water Below Grid Plate
1443 62 7.4744E-02 5 -7 imp:n=1 u=1400 $ Grid Plate With Adapter
1444 33 7.7699E-02 7 -9 imp:n=1 u=1400 $ Lower Adapter
1445 1 9.9961E-02 -132 131 -134 133 imp:n=1 u=1405 lat=1 fill=-1:2 -1:2 0:0 $ Fuel Assemblies
      1405 1405 1405 1405
      1405 1403 1404 1405
      1405 1401 1402 1405
      1405 1405 1405 1405
1446 0 9 -10 imp:n=1 u=1400 fill=1405 (-1.9431 -1.9431 0) $ Fuel Bundle
1447 32 9.1839E-02 10 -12 262 imp:n=1 u=1400 $ Upper Assembly
1448 1 9.9961E-02 12 262 imp:n=1 u=1400 $ Water Above Core
1449 0 10 -262 imp:n=1 u=1400 fill=1405 (-1.9431 -1.9431 0)
c
c ----- Position C-3 : 4-Rod Fuel Cluster -----
c ----- NW Fuel Rod : 11781 ----- ---
1501 14 8.7412E-02 (-103 -151):(102 -103 -156) imp:n=1 u=1501 $ Bottom End Fitting
1502 11 8.6735E-02 103 -104 -152 imp:n=1 u=1501 $ Bottom Graphite Reflector
1503 12 6.4196E-02 104 -105 -153 imp:n=1 u=1501 $ Moly Poison Disc
1504 13 4.3026E-02 105 -106 -154 imp:n=1 u=1501 $ Zirconium Rod
1570 2 5.0820E-05 105 -106 154 -159 imp:n=1 u=1501 $ Zr/Fuel Gap
1505 130 8.9332E-02 105 -106 159 -155 imp:n=1 u=1501 $ Fuel Rod
1506 11 8.6735E-02 106 -107 -152 imp:n=1 u=1501 $ Top Graphite Reflector
1507 2 5.0820E-05 (-103:104:152) (-104:105:153) (-105:106:155)
      (-106:107:152) (103 -108 -156) imp:n=1 u=1501 $ Air Gap
1508 14 8.7412E-02 102 -109 156 -157 imp:n=1 u=1501 $ Cladding
1509 14 8.7412E-02 (108 -158):(108 -109 -156) imp:n=1 u=1501 $ Top End Fitting
1510 1 9.9961E-02 157:(-102 151):(109 158) imp:n=1 u=1501 $ Water
c
c ----- NE Fuel Rod : 11782 ----- ---
1511 14 8.7412E-02 (-103 -151):(102 -103 -156) imp:n=1 u=1502 $ Bottom End Fitting
1512 11 8.6735E-02 103 -104 -152 imp:n=1 u=1502 $ Bottom Graphite Reflector
1513 12 6.4196E-02 104 -105 -153 imp:n=1 u=1502 $ Moly Poison Disc
1514 13 4.3026E-02 105 -106 -154 imp:n=1 u=1502 $ Zirconium Rod
1571 2 5.0820E-05 105 -106 154 -159 imp:n=1 u=1502 $ Zr/Fuel Gap
1515 131 8.9074E-02 105 -106 159 -155 imp:n=1 u=1502 $ Fuel Rod
1516 11 8.6735E-02 106 -107 -152 imp:n=1 u=1502 $ Top Graphite Reflector
1517 2 5.0820E-05 (-103:104:152) (-104:105:153) (-105:106:155)

```

Fundamental - FUND

NRAD-FUND-RESR-001
CRIT-REAC-COEF

```

(-106:107:152) (103 -108 -156) imp:n=1 u=1502 $ Air Gap
1518 14 8.7412E-02 102 -109 156 -157 imp:n=1 u=1502 $ Cladding
1519 14 8.7412E-02 (108 -158):(108 -109 -156) imp:n=1 u=1502 $ Top End Fitting
1520 1 9.9961E-02 157:(-102 151):(109 158) imp:n=1 u=1502 $ Water
c
c ----- SW Fuel Rod : 11780 -----
1521 14 8.7412E-02 (-103 -151):(102 -103 -156) imp:n=1 u=1503 $ Bottom End Fitting
1522 11 8.6735E-02 103 -104 -152 imp:n=1 u=1503 $ Bottom Graphite Reflector
1523 12 6.4196E-02 104 -105 -153 imp:n=1 u=1503 $ Moly Poison Disc
1524 13 4.3026E-02 105 -106 -154 imp:n=1 u=1503 $ Zirconium Rod
1572 2 5.0820E-05 105 -106 154 -159 imp:n=1 u=1503 $ Zr/Fuel Gap
1525 129 8.9148E-02 105 -106 159 -155 imp:n=1 u=1503 $ Fuel Rod
1526 11 8.6735E-02 106 -107 -152 imp:n=1 u=1503 $ Top Graphite Reflector
1527 2 5.0820E-05 (-103:104:152) (-104:105:153) (-105:106:155)
(-106:107:152) (103 -108 -156) imp:n=1 u=1503 $ Air Gap
1528 14 8.7412E-02 102 -109 156 -157 imp:n=1 u=1503 $ Cladding
1529 14 8.7412E-02 (108 -158):(108 -109 -156) imp:n=1 u=1503 $ Top End Fitting
1530 1 9.9961E-02 157:(-102 151):(109 158) imp:n=1 u=1503 $ Water
c
c ----- SE Fuel Rod : 11783 -----
1531 14 8.7412E-02 (-103 -151):(102 -103 -156) imp:n=1 u=1504 $ Bottom End Fitting
1532 11 8.6735E-02 103 -104 -152 imp:n=1 u=1504 $ Bottom Graphite Reflector
1533 12 6.4196E-02 104 -105 -153 imp:n=1 u=1504 $ Moly Poison Disc
1534 13 4.3026E-02 105 -106 -154 imp:n=1 u=1504 $ Zirconium Rod
1573 2 5.0820E-05 105 -106 154 -159 imp:n=1 u=1504 $ Zr/Fuel Gap
1535 132 8.9084E-02 105 -106 159 -155 imp:n=1 u=1504 $ Fuel Rod
1536 11 8.6735E-02 106 -107 -152 imp:n=1 u=1504 $ Top Graphite Reflector
1537 2 5.0820E-05 (-103:104:152) (-104:105:153) (-105:106:155)
(-106:107:152) (103 -108 -156) imp:n=1 u=1504 $ Air Gap
1538 14 8.7412E-02 102 -109 156 -157 imp:n=1 u=1504 $ Cladding
1539 14 8.7412E-02 (108 -158):(108 -109 -156) imp:n=1 u=1504 $ Top End Fitting
1540 1 9.9961E-02 157:(-102 151):(109 158) imp:n=1 u=1504 $ Water
c
c ----- Fuel Assembly -----
1541 1 9.9961E-02 -5 imp:n=1 u=1500 $ Water Below Grid Plate
1543 62 7.4744E-02 5 -7 imp:n=1 u=1500 $ Grid Plate With Adapter
1544 33 7.7699E-02 7 -9 imp:n=1 u=1500 $ Lower Adapter
1545 1 9.9961E-02 -132 131 -134 133 imp:n=1 u=1505 lat=1 fill=-1:2 -1:2 0:0 $ Fuel Assemblies
1505 1505 1505 1505
1505 1503 1504 1505
1505 1501 1502 1505
1505 1505 1505 1505
1546 0 9 -10 imp:n=1 u=1500 fill=1505 (-1.9431 -1.9431 0) $ Fuel Bundle
1547 31 9.3070E-02 10 -12 imp:n=1 u=1500 $ Upper Assembly
1548 1 9.9961E-02 12 imp:n=1 u=1500 $ Water Above Core
c
c ----- Position C-4 : Sample Irradiation Cluster -----
c ----- NW Fuel Rod : 11761 -----
1601 14 8.7412E-02 (-103 -151):(102 -103 -156) imp:n=1 u=1601 $ Bottom End Fitting
1602 11 8.6735E-02 103 -104 -152 imp:n=1 u=1601 $ Bottom Graphite Reflector
1603 12 6.4196E-02 104 -105 -153 imp:n=1 u=1601 $ Moly Poison Disc
1604 13 4.3026E-02 105 -106 -154 imp:n=1 u=1601 $ Zirconium Rod
1670 2 5.0820E-05 105 -106 154 -159 imp:n=1 u=1601 $ Zr/Fuel Gap
1605 110 8.9148E-02 105 -106 159 -155 imp:n=1 u=1601 $ Fuel Rod
1606 11 8.6735E-02 106 -107 -152 imp:n=1 u=1601 $ Top Graphite Reflector
1607 2 5.0820E-05 (-103:104:152) (-104:105:153) (-105:106:155)
(-106:107:152) (103 -108 -156) imp:n=1 u=1601 $ Air Gap
1608 14 8.7412E-02 102 -109 156 -157 imp:n=1 u=1601 $ Cladding
1609 14 8.7412E-02 (108 -158):(108 -109 -156) imp:n=1 u=1601 $ Top End Fitting
1610 1 9.9961E-02 157:(-102 151):(109 158) imp:n=1 u=1601 $ Water
c
c ----- NE Fuel Rod : 11762 -----
1611 14 8.7412E-02 (-103 -151):(102 -103 -156) imp:n=1 u=1602 $ Bottom End Fitting
1612 11 8.6735E-02 103 -104 -152 imp:n=1 u=1602 $ Bottom Graphite Reflector
1613 12 6.4196E-02 104 -105 -153 imp:n=1 u=1602 $ Moly Poison Disc
1614 13 4.3026E-02 105 -106 -154 imp:n=1 u=1602 $ Zirconium Rod
1671 2 5.0820E-05 105 -106 154 -159 imp:n=1 u=1602 $ Zr/Fuel Gap
1615 111 8.9229E-02 105 -106 159 -155 imp:n=1 u=1602 $ Fuel Rod
1616 11 8.6735E-02 106 -107 -152 imp:n=1 u=1602 $ Top Graphite Reflector
1617 2 5.0820E-05 (-103:104:152) (-104:105:153) (-105:106:155)
(-106:107:152) (103 -108 -156) imp:n=1 u=1602 $ Air Gap
1618 14 8.7412E-02 102 -109 156 -157 imp:n=1 u=1602 $ Cladding
1619 14 8.7412E-02 (108 -158):(108 -109 -156) imp:n=1 u=1602 $ Top End Fitting
1620 1 9.9961E-02 157:(-102 151):(109 158) imp:n=1 u=1602 $ Water
c
c ----- SW Water Hole (Irradiation Position) -----

```

Fundamental - FUND

NRAD-FUND-RESR-001
CRIT-REAC-COEF

```

1621 14 8.7412E-02 -201 -251 imp:n=1 u=1603 $ Bottom End Fitting
1622 23 6.7723E-02 201 -202 -253 imp:n=1 u=1603 $ Guide Tube Bottom
1623 25 6.1351E-02 202 -203 252 -253 imp:n=1 u=1603 $ Guide Tube
1624 1 9.9961E-02 (-201 251):253:(203 252) imp:n=1 u=1603 $ Water Outside Guide Tube
1625 1 9.9961E-02 202 -252 imp:n=1 u=1603 $ Water Hole
c
c ----- SE Fuel Rod : 11763 ----- ---
1631 14 8.7412E-02 (-103 -151):(102 -103 -156) imp:n=1 u=1604 $ Bottom End Fitting
1632 11 8.6735E-02 103 -104 -152 imp:n=1 u=1604 $ Bottom Graphite Reflector
1633 12 6.4196E-02 104 -105 -153 imp:n=1 u=1604 $ Moly Poison Disc
1634 13 4.3026E-02 105 -106 -154 imp:n=1 u=1604 $ Zirconium Rod
1673 2 5.0820E-05 105 -106 154 -159 imp:n=1 u=1604 $ Zr/Fuel Gap
1635 112 8.9575E-02 105 -106 159 -155 imp:n=1 u=1604 $ Fuel Rod
1636 11 8.6735E-02 106 -107 -152 imp:n=1 u=1604 $ Top Graphite Reflector
1637 2 5.0820E-05 (-103:104:152) (-104:105:153) (-105:106:155)
(-106:107:152) (103 -108 -156) imp:n=1 u=1604 $ Air Gap
1638 14 8.7412E-02 102 -109 156 -157 imp:n=1 u=1604 $ Cladding
1639 14 8.7412E-02 (108 -158):(108 -109 -156) imp:n=1 u=1604 $ Top End Fitting
1640 1 9.9961E-02 157:(-102 151):(109 158) imp:n=1 u=1604 $ Water
c
c ----- Fuel Assembly -----
1641 1 9.9961E-02 -5 imp:n=1 u=1600 $ Water Below Grid Plate
1643 62 7.4744E-02 5 -7 imp:n=1 u=1600 $ Grid Plate With Adapter
1644 33 7.7699E-02 7 -9 imp:n=1 u=1600 $ Lower Adapter
1645 1 9.9961E-02 -132 131 -134 133 imp:n=1 u=1605 lat=1 fill=-1:2 -1:2 0:0 $ Fuel Assemblies
1605 1605 1605 1605
1605 1603 1604 1605
1605 1601 1602 1605
1605 1605 1605 1605
1646 0 9 -10 imp:n=1 u=1600 fill=1605 (-1.9431 -1.9431 0) $ Fuel Bundle
1647 32 9.1839E-02 10 -12 263 imp:n=1 u=1600 $ Upper Assembly
1648 1 9.9961E-02 12 263 imp:n=1 u=1600 $ Water Above Core
1649 0 10 -263 imp:n=1 u=1600 fill=1605 (-1.9431 -1.9431 0)
c
c ----- Position C-5 : 4-Rod Fuel Cluster -----
c ----- NW Fuel Rod : 11795 ----- ---
1701 14 8.7412E-02 (-103 -151):(102 -103 -156) imp:n=1 u=1701 $ Bottom End Fitting
1702 11 8.6735E-02 103 -104 -152 imp:n=1 u=1701 $ Bottom Graphite Reflector
1703 12 6.4196E-02 104 -105 -153 imp:n=1 u=1701 $ Moly Poison Disc
1704 13 4.3026E-02 105 -106 -154 imp:n=1 u=1701 $ Zirconium Rod
1770 2 5.0820E-05 105 -106 154 -159 imp:n=1 u=1701 $ Zr/Fuel Gap
1705 144 8.9530E-02 105 -106 159 -155 imp:n=1 u=1701 $ Fuel Rod
1706 11 8.6735E-02 106 -107 -152 imp:n=1 u=1701 $ Top Graphite Reflector
1707 2 5.0820E-05 (-103:104:152) (-104:105:153) (-105:106:155)
(-106:107:152) (103 -108 -156) imp:n=1 u=1701 $ Air Gap
1708 14 8.7412E-02 102 -109 156 -157 imp:n=1 u=1701 $ Cladding
1709 14 8.7412E-02 (108 -158):(108 -109 -156) imp:n=1 u=1701 $ Top End Fitting
1710 1 9.9961E-02 157:(-102 151):(109 158) imp:n=1 u=1701 $ Water
c
c ----- NE Fuel Rod : 11792 ----- ---
1711 14 8.7412E-02 (-103 -151):(102 -103 -156) imp:n=1 u=1702 $ Bottom End Fitting
1712 11 8.6735E-02 103 -104 -152 imp:n=1 u=1702 $ Bottom Graphite Reflector
1713 12 6.4196E-02 104 -105 -153 imp:n=1 u=1702 $ Moly Poison Disc
1714 13 4.3026E-02 105 -106 -154 imp:n=1 u=1702 $ Zirconium Rod
1771 2 5.0820E-05 105 -106 154 -159 imp:n=1 u=1702 $ Zr/Fuel Gap
1715 141 8.8974E-02 105 -106 159 -155 imp:n=1 u=1702 $ Fuel Rod
1716 11 8.6735E-02 106 -107 -152 imp:n=1 u=1702 $ Top Graphite Reflector
1717 2 5.0820E-05 (-103:104:152) (-104:105:153) (-105:106:155)
(-106:107:152) (103 -108 -156) imp:n=1 u=1702 $ Air Gap
1718 14 8.7412E-02 102 -109 156 -157 imp:n=1 u=1702 $ Cladding
1719 14 8.7412E-02 (108 -158):(108 -109 -156) imp:n=1 u=1702 $ Top End Fitting
1720 1 9.9961E-02 157:(-102 151):(109 158) imp:n=1 u=1702 $ Water
c
c ----- SW Fuel Rod : 11794 ----- ---
1721 14 8.7412E-02 (-103 -151):(102 -103 -156) imp:n=1 u=1703 $ Bottom End Fitting
1722 11 8.6735E-02 103 -104 -152 imp:n=1 u=1703 $ Bottom Graphite Reflector
1723 12 6.4196E-02 104 -105 -153 imp:n=1 u=1703 $ Moly Poison Disc
1724 13 4.3026E-02 105 -106 -154 imp:n=1 u=1703 $ Zirconium Rod
1772 2 5.0820E-05 105 -106 154 -159 imp:n=1 u=1703 $ Zr/Fuel Gap
1725 143 8.9194E-02 105 -106 159 -155 imp:n=1 u=1703 $ Fuel Rod
1726 11 8.6735E-02 106 -107 -152 imp:n=1 u=1703 $ Top Graphite Reflector
1727 2 5.0820E-05 (-103:104:152) (-104:105:153) (-105:106:155)
(-106:107:152) (103 -108 -156) imp:n=1 u=1703 $ Air Gap
1728 14 8.7412E-02 102 -109 156 -157 imp:n=1 u=1703 $ Cladding
1729 14 8.7412E-02 (108 -158):(108 -109 -156) imp:n=1 u=1703 $ Top End Fitting
1730 1 9.9961E-02 157:(-102 151):(109 158) imp:n=1 u=1703 $ Water

```

Fundamental - FUND

NRAD-FUND-RESR-001
CRIT-REAC-COEF

```

c
c ----- SE Fuel Rod : 11793 -----
1731 14 8.7412E-02 (-103 -151):(102 -103 -156) imp:n=1 u=1704 $ Bottom End Fitting
1732 11 8.6735E-02 103 -104 -152 imp:n=1 u=1704 $ Bottom Graphite Reflector
1733 12 6.4196E-02 104 -105 -153 imp:n=1 u=1704 $ Moly Poison Disc
1734 13 4.3026E-02 105 -106 -154 imp:n=1 u=1704 $ Zirconium Rod
1773 2 5.0820E-05 105 -106 154 -159 imp:n=1 u=1704 $ Zr/Fuel Gap
1735 142 8.9315E-02 105 -106 159 -155 imp:n=1 u=1704 $ Fuel Rod
1736 11 8.6735E-02 106 -107 -152 imp:n=1 u=1704 $ Top Graphite Reflector
1737 2 5.0820E-05 (-103:104:152) (-104:105:153) (-105:106:155)
(-106:107:152) (103 -108 -156) imp:n=1 u=1704 $ Air Gap
1738 14 8.7412E-02 102 -109 156 -157 imp:n=1 u=1704 $ Cladding
1739 14 8.7412E-02 (108 -158):(108 -109 -156) imp:n=1 u=1704 $ Top End Fitting
1740 1 9.9961E-02 157:(-102 151):(109 158) imp:n=1 u=1704 $ Water
c
c ----- Fuel Assembly -----
1741 1 9.9961E-02 -5 imp:n=1 u=1700 $ Water Below Grid Plate
1743 62 7.4744E-02 5 -7 imp:n=1 u=1700 $ Grid Plate With Adapter
1744 33 7.7699E-02 7 -9 imp:n=1 u=1700 $ Lower Adapter
1745 1 9.9961E-02 -132 131 -134 133 imp:n=1 u=1705 lat=1 fill=-1:2 -1:2 0:0 $ Fuel Assemblies
1705 1705 1705 1705
1705 1703 1704 1705
1705 1701 1702 1705
1705 1705 1705 1705
1746 0 9 -10 imp:n=1 u=1700 fill=1705 (-1.9431 -1.9431 0) $ Fuel Bundle
1747 31 9.3070E-02 10 -12 imp:n=1 u=1700 $ Upper Assembly
1748 1 9.9961E-02 12 imp:n=1 u=1700 $ Water Above Core
c
c ----- Position C-6 : East Beam Tube Support -----
1801 1 9.9961E-02 -5 imp:n=1 u=1800 $ Water Below Grid Plate
1803 64 7.5685E-02 5 -7 imp:n=1 u=1800 $ Grid Plate With Support
1804 51 9.1752E-02 7 -401 imp:n=1 u=1800 $ Beam Tube Support
1805 1 9.9961E-02 401 imp:n=1 u=1800 $ Water Above Support
c
c ----- Position D-1 : Graphite Reflector -----
1901 1 9.9961E-02 -5 imp:n=1 u=1900 $ Water Below Grid Plate
1903 63 6.9890E-02 5 -7 imp:n=1 u=1900 $ Grid Plate With Adapter
1904 44 7.6788E-02 7 -9 imp:n=1 u=1900 $ Lower Adapter
1905 41 7.8699E-02 (9 -10) (-9:303:354) (-9:303:355) (-9:305:351) (-306:10:356)
(-306:10:357) (331 -332 333 -334) (-335 -336 -337 -338)
imp:n=1 u=1900 $ Graphite Block
1906 42 6.0307E-02 307 -10 -356 imp:n=1 u=1900 $ Top Screw NE
1907 42 6.0307E-02 307 -10 -357 imp:n=1 u=1900 $ Top Screw SW
1908 1 9.9961E-02 306 -307 -356 imp:n=1 u=1900 $ Water in NE Top Hole
1909 1 9.9961E-02 306 -307 -357 imp:n=1 u=1900 $ Water in SW Top Hole
1910 42 6.0307E-02 9 -302 -352 imp:n=1 u=1900 $ Bottom Dowel NE
1911 42 6.0307E-02 9 -302 -353 imp:n=1 u=1900 $ Bottom Dowel SW
1912 42 6.0307E-02 9 -304 -351 imp:n=1 u=1900 $ Tie Rod
1913 1 9.9961E-02 (9 -303 352 -354):(302 -303 -354) imp:n=1 u=1900 $ Water in NE Bottom Hole
1914 1 9.9961E-02 (9 -303 353 -355):(302 -303 -355) imp:n=1 u=1900 $ Water in SW Bottom Hole
1915 1 9.9961E-02 (304 -305 -351) imp:n=1 u=1900 $ Water in Tie Rod Hole
1916 43 9.1820E-02 10 -309 imp:n=1 u=1900 $ Upper Assembly
1917 1 9.9961E-02 309 imp:n=1 u=1900 $ Water Above Core
1918 1 9.9961E-02 (9 -10) (-331:332:-333:334:335:336:337:338) imp:n=1 u=1900 $ Water Around
Assembly
c
c ----- Position D-2 : Shim Rod 1 Control Cluster -----
c ----- NW Fuel Rod : 11755 -----
2001 14 8.7412E-02 (-103 -151):(102 -103 -156) imp:n=1 u=2001 $ Bottom End Fitting
2002 11 8.6735E-02 103 -104 -152 imp:n=1 u=2001 $ Bottom Graphite Reflector
2003 12 6.4196E-02 104 -105 -153 imp:n=1 u=2001 $ Moly Poison Disc
2004 13 4.3026E-02 105 -106 -154 imp:n=1 u=2001 $ Zirconium Rod
2070 2 5.0820E-05 105 -106 154 -159 imp:n=1 u=2001 $ Zr/Fuel Gap
2005 104 8.9597E-02 105 -106 159 -155 imp:n=1 u=2001 $ Fuel Rod
2006 11 8.6735E-02 106 -107 -152 imp:n=1 u=2001 $ Top Graphite Reflector
2007 2 5.0820E-05 (-103:104:152) (-104:105:153) (-105:106:155)
(-106:107:152) (103 -108 -156) imp:n=1 u=2001 $ Air Gap
2008 14 8.7412E-02 102 -109 156 -157 imp:n=1 u=2001 $ Cladding
2009 14 8.7412E-02 (108 -158):(108 -109 -156) imp:n=1 u=2001 $ Top End Fitting
2010 1 9.9961E-02 157:(-102 151):(109 158) imp:n=1 u=2001 $ Water
c
c ----- NE Fuel Rod : 11757 -----
2011 14 8.7412E-02 (-103 -151):(102 -103 -156) imp:n=1 u=2002 $ Bottom End Fitting
2012 11 8.6735E-02 103 -104 -152 imp:n=1 u=2002 $ Bottom Graphite Reflector
2013 12 6.4196E-02 104 -105 -153 imp:n=1 u=2002 $ Moly Poison Disc
2014 13 4.3026E-02 105 -106 -154 imp:n=1 u=2002 $ Zirconium Rod

```

Fundamental - FUND

NRAD-FUND-RESR-001
CRIT-REAC-COEF

```

2071 2 5.0820E-05 105 -106 154 -159 imp:n=1 u=2002 $ Zr/Fuel Gap
2015 106 8.9289E-02 105 -106 159 -155 imp:n=1 u=2002 $ Fuel Rod
2016 11 8.6735E-02 106 -107 -152 imp:n=1 u=2002 $ Top Graphite Reflector
2017 2 5.0820E-05 (-103:104:152) (-104:105:153) (-105:106:155)
(-106:107:152) (103 -108 -156) imp:n=1 u=2002 $ Air Gap
2018 14 8.7412E-02 102 -109 156 -157 imp:n=1 u=2002 $ Cladding
2019 14 8.7412E-02 (108 -158):(108 -109 -156) imp:n=1 u=2002 $ Top End Fitting
2020 1 9.9961E-02 157:(-102 151):(109 158) imp:n=1 u=2002 $ Water
c
c ----- SW Fuel Rod : 11756 ----- ---
2021 14 8.7412E-02 (-103 -151):(102 -103 -156) imp:n=1 u=2003 $ Bottom End Fitting
2022 11 8.6735E-02 103 -104 -152 imp:n=1 u=2003 $ Bottom Graphite Reflector
2023 12 6.4196E-02 104 -105 -153 imp:n=1 u=2003 $ Moly Poison Disc
2024 13 4.3026E-02 105 -106 -154 imp:n=1 u=2003 $ Zirconium Rod
2072 2 5.0820E-05 105 -106 154 -159 imp:n=1 u=2003 $ Zr/Fuel Gap
2025 105 8.9329E-02 105 -106 159 -155 imp:n=1 u=2003 $ Fuel Rod
2026 11 8.6735E-02 106 -107 -152 imp:n=1 u=2003 $ Top Graphite Reflector
2027 2 5.0820E-05 (-103:104:152) (-104:105:153) (-105:106:155)
(-106:107:152) (103 -108 -156) imp:n=1 u=2003 $ Air Gap
2028 14 8.7412E-02 102 -109 156 -157 imp:n=1 u=2003 $ Cladding
2029 14 8.7412E-02 (108 -158):(108 -109 -156) imp:n=1 u=2003 $ Top End Fitting
2030 1 9.9961E-02 157:(-102 151):(109 158) imp:n=1 u=2003 $ Water
c
c ----- SE Control Rod : Shim 1 ----- ---
2031 14 8.7412E-02 -201 -251 imp:n=1 u=2004 $ Bottom End Fitting
2032 23 6.7723E-02 201 -202 -253 imp:n=1 u=2004 $ Guide Tube Bottom
2033 25 6.1351E-02 202 -203 252 -253 imp:n=1 u=2004 $ Guide Tube
2034 1 9.9961E-02 (-201 251):253:(203 252) imp:n=1 u=2004 $ Water Outside Guide Tube
c
2050 22 5.9939E-02 231 -232 -275 imp:n=1 u=2006 $ Bottom End Fitting
2051 21 1.3514E-01 232 -233 -271 imp:n=1 u=2006 $ Absorber
2052 22 5.9939E-02 233 -234 272 -271 imp:n=1 u=2006 $ Spacer Disc
2053 22 5.9939E-02 234 -235 273 -274 imp:n=1 u=2006 $ Spacer Tube
2054 0 (232 -234 271 -275):(233 -234 -272):(234 -235 -273):(234 -235 274 -275)
imp:n=1 u=2006 $ Void Space
2055 22 5.9939E-02 (235 -236 -275):(236 -237 -277) imp:n=1 u=2006 $ Top End Fitting
2056 22 5.9939E-02 231 -236 275 -276 imp:n=1 u=2006 $ Cladding
2057 24 6.8709E-02 237 -238 -278 imp:n=1 u=2006 $ Attachment Interface
2058 2 5.0820E-05 238 -239 -279 imp:n=1 u=2006 $ Inside Extension Rod
2059 22 5.9939E-02 238 -239 279 -280 imp:n=1 u=2006 $ Extension Rod
2060 1 9.9961E-02 (-231 -276):(276):(236 278):(238 280):(236 -237 277):(239)
imp:n=1 u=2006 $ Water around Control Rod
c
c ----- Fuel Assembly -----
2041 1 9.9961E-02 -5 imp:n=1 u=2000 $ Water Below Grid Plate
2043 62 7.4744E-02 5 -7 imp:n=1 u=2000 $ Grid Plate With Adapter
2044 33 7.7699E-02 7 -9 imp:n=1 u=2000 $ Lower Adapter
2045 1 9.9961E-02 -132 131 -134 133 imp:n=1 u=2005 lat=1 fill=-1:2 -1:2 0:0 $ Fuel Assemblies
2005 2005 2005 2005
2005 2003 2004 2005
2005 2001 2002 2005
2005 2005 2005 2005
2046 0 9 -10 imp:n=1 u=2000 fill=2005 (-1.9431 -1.9431 0) $ Fuel Bundle
2047 32 9.1839E-02 10 -12 264 imp:n=1 u=2000 $ Upper Assembly
2048 1 9.9961E-02 12 264 imp:n=1 u=2000 $ Water Above Core
2049 0 10 -264 imp:n=1 u=2000 fill=2005 (-1.9431 -1.9431 0)
c
c ----- Position D-3 : 4-Rod Fuel Cluster ----- ---
c ----- NW Fuel Rod : 11772 ----- ---
2101 14 8.7412E-02 (-103 -151):(102 -103 -156) imp:n=1 u=2101 $ Bottom End Fitting
2102 11 8.6735E-02 103 -104 -152 imp:n=1 u=2101 $ Bottom Graphite Reflector
2103 12 6.4196E-02 104 -105 -153 imp:n=1 u=2101 $ Moly Poison Disc
2104 13 4.3026E-02 105 -106 -154 imp:n=1 u=2101 $ Zirconium Rod
2170 2 5.0820E-05 105 -106 154 -159 imp:n=1 u=2101 $ Zr/Fuel Gap
2105 121 8.9089E-02 105 -106 159 -155 imp:n=1 u=2101 $ Fuel Rod
2106 11 8.6735E-02 106 -107 -152 imp:n=1 u=2101 $ Top Graphite Reflector
2107 2 5.0820E-05 (-103:104:152) (-104:105:153) (-105:106:155)
(-106:107:152) (103 -108 -156) imp:n=1 u=2101 $ Air Gap
2108 14 8.7412E-02 102 -109 156 -157 imp:n=1 u=2101 $ Cladding
2109 14 8.7412E-02 (108 -158):(108 -109 -156) imp:n=1 u=2101 $ Top End Fitting
2110 1 9.9961E-02 157:(-102 151):(109 158) imp:n=1 u=2101 $ Water
c
c ----- NE Fuel Rod : 11773 ----- ---
2111 14 8.7412E-02 (-103 -151):(102 -103 -156) imp:n=1 u=2102 $ Bottom End Fitting
2112 11 8.6735E-02 103 -104 -152 imp:n=1 u=2102 $ Bottom Graphite Reflector
2113 12 6.4196E-02 104 -105 -153 imp:n=1 u=2102 $ Moly Poison Disc

```

Fundamental - FUND

NRAD-FUND-RESR-001
CRIT-REAC-COEF

```

2114 13 4.3026E-02 105 -106 -154 imp:n=1 u=2102 $ Zirconium Rod
2171 2 5.0820E-05 105 -106 154 -159 imp:n=1 u=2102 $ Zr/Fuel Gap
2115 122 8.9311E-02 105 -106 159 -155 imp:n=1 u=2102 $ Fuel Rod
2116 11 8.6735E-02 106 -107 -152 imp:n=1 u=2102 $ Top Graphite Reflector
2117 2 5.0820E-05 (-103:104:152) (-104:105:153) (-105:106:155)
(-106:107:152) (103 -108 -156) imp:n=1 u=2102 $ Air Gap
2118 14 8.7412E-02 102 -109 156 -157 imp:n=1 u=2102 $ Cladding
2119 14 8.7412E-02 (108 -158):(108 -109 -156) imp:n=1 u=2102 $ Top End Fitting
2120 1 9.9961E-02 157:(-102 151):(109 158) imp:n=1 u=2102 $ Water
c
c ----- SW Fuel Rod : 11774 ----- ---
2121 14 8.7412E-02 (-103 -151):(102 -103 -156) imp:n=1 u=2103 $ Bottom End Fitting
2122 11 8.6735E-02 103 -104 -152 imp:n=1 u=2103 $ Bottom Graphite Reflector
2123 12 6.4196E-02 104 -105 -153 imp:n=1 u=2103 $ Moly Poison Disc
2124 13 4.3026E-02 105 -106 -154 imp:n=1 u=2103 $ Zirconium Rod
2172 2 5.0820E-05 105 -106 154 -159 imp:n=1 u=2103 $ Zr/Fuel Gap
2125 123 9.0290E-02 105 -106 159 -155 imp:n=1 u=2103 $ Fuel Rod
2126 11 8.6735E-02 106 -107 -152 imp:n=1 u=2103 $ Top Graphite Reflector
2127 2 5.0820E-05 (-103:104:152) (-104:105:153) (-105:106:155)
(-106:107:152) (103 -108 -156) imp:n=1 u=2103 $ Air Gap
2128 14 8.7412E-02 102 -109 156 -157 imp:n=1 u=2103 $ Cladding
2129 14 8.7412E-02 (108 -158):(108 -109 -156) imp:n=1 u=2103 $ Top End Fitting
2130 1 9.9961E-02 157:(-102 151):(109 158) imp:n=1 u=2103 $ Water
c
c ----- SE Fuel Rod : 11775 ----- ---
2131 14 8.7412E-02 (-103 -151):(102 -103 -156) imp:n=1 u=2104 $ Bottom End Fitting
2132 11 8.6735E-02 103 -104 -152 imp:n=1 u=2104 $ Bottom Graphite Reflector
2133 12 6.4196E-02 104 -105 -153 imp:n=1 u=2104 $ Moly Poison Disc
2134 13 4.3026E-02 105 -106 -154 imp:n=1 u=2104 $ Zirconium Rod
2173 2 5.0820E-05 105 -106 154 -159 imp:n=1 u=2104 $ Zr/Fuel Gap
2135 124 8.9272E-02 105 -106 159 -155 imp:n=1 u=2104 $ Fuel Rod
2136 11 8.6735E-02 106 -107 -152 imp:n=1 u=2104 $ Top Graphite Reflector
2137 2 5.0820E-05 (-103:104:152) (-104:105:153) (-105:106:155)
(-106:107:152) (103 -108 -156) imp:n=1 u=2104 $ Air Gap
2138 14 8.7412E-02 102 -109 156 -157 imp:n=1 u=2104 $ Cladding
2139 14 8.7412E-02 (108 -158):(108 -109 -156) imp:n=1 u=2104 $ Top End Fitting
2140 1 9.9961E-02 157:(-102 151):(109 158) imp:n=1 u=2104 $ Water
c
c ----- Fuel Assembly -----
2141 1 9.9961E-02 -5 imp:n=1 u=2100 $ Water Below Grid Plate
2143 62 7.4744E-02 5 -7 imp:n=1 u=2100 $ Grid Plate With Adapter
2144 33 7.7699E-02 7 -9 imp:n=1 u=2100 $ Lower Adapter
2145 1 9.9961E-02 -132 131 -134 133 imp:n=1 u=2105 lat=1 fill=-1:2 -1:2 0:0 $ Fuel Assemblies
2105 2105 2105 2105
2105 2103 2104 2105
2105 2101 2102 2105
2105 2105 2105 2105
2146 0 9 -10 imp:n=1 u=2100 fill=2105 (-1.9431 -1.9431 0) $ Fuel Bundle
2147 31 9.3070E-02 10 -12 imp:n=1 u=2100 $ Upper Assembly
2148 1 9.9961E-02 12 imp:n=1 u=2100 $ Water Above Core
c
c ----- Position D-4 : 4-Rod Fuel Cluster -----
c ----- NW Fuel Rod : 11768 ----- ---
2201 14 8.7412E-02 (-103 -151):(102 -103 -156) imp:n=1 u=2201 $ Bottom End Fitting
2202 11 8.6735E-02 103 -104 -152 imp:n=1 u=2201 $ Bottom Graphite Reflector
2203 12 6.4196E-02 104 -105 -153 imp:n=1 u=2201 $ Moly Poison Disc
2204 13 4.3026E-02 105 -106 -154 imp:n=1 u=2201 $ Zirconium Rod
2270 2 5.0820E-05 105 -106 154 -159 imp:n=1 u=2201 $ Zr/Fuel Gap
2205 117 8.9003E-02 105 -106 159 -155 imp:n=1 u=2201 $ Fuel Rod
2206 11 8.6735E-02 106 -107 -152 imp:n=1 u=2201 $ Top Graphite Reflector
2207 2 5.0820E-05 (-103:104:152) (-104:105:153) (-105:106:155)
(-106:107:152) (103 -108 -156) imp:n=1 u=2201 $ Air Gap
2208 14 8.7412E-02 102 -109 156 -157 imp:n=1 u=2201 $ Cladding
2209 14 8.7412E-02 (108 -158):(108 -109 -156) imp:n=1 u=2201 $ Top End Fitting
2210 1 9.9961E-02 157:(-102 151):(109 158) imp:n=1 u=2201 $ Water
c
c ----- NE Fuel Rod : 11769 ----- ---
2211 14 8.7412E-02 (-103 -151):(102 -103 -156) imp:n=1 u=2202 $ Bottom End Fitting
2212 11 8.6735E-02 103 -104 -152 imp:n=1 u=2202 $ Bottom Graphite Reflector
2213 12 6.4196E-02 104 -105 -153 imp:n=1 u=2202 $ Moly Poison Disc
2214 13 4.3026E-02 105 -106 -154 imp:n=1 u=2202 $ Zirconium Rod
2271 2 5.0820E-05 105 -106 154 -159 imp:n=1 u=2202 $ Zr/Fuel Gap
2215 118 8.8885E-02 105 -106 159 -155 imp:n=1 u=2202 $ Fuel Rod
2216 11 8.6735E-02 106 -107 -152 imp:n=1 u=2202 $ Top Graphite Reflector
2217 2 5.0820E-05 (-103:104:152) (-104:105:153) (-105:106:155)
(-106:107:152) (103 -108 -156) imp:n=1 u=2202 $ Air Gap

```

Fundamental - FUND

NRAD-FUND-RESR-001
CRIT-REAC-COEF

```

2218 14 8.7412E-02 102 -109 156 -157 imp:n=1 u=2202 $ Cladding
2219 14 8.7412E-02 (108 -158):(108 -109 -156) imp:n=1 u=2202 $ Top End Fitting
2220 1 9.9961E-02 157:(-102 151):(109 158) imp:n=1 u=2202 $ Water
c
c ----- SW Fuel Rod : 11770 -----
2221 14 8.7412E-02 (-103 -151):(102 -103 -156) imp:n=1 u=2203 $ Bottom End Fitting
2222 11 8.6735E-02 103 -104 -152 imp:n=1 u=2203 $ Bottom Graphite Reflector
2223 12 6.4196E-02 104 -105 -153 imp:n=1 u=2203 $ Moly Poison Disc
2224 13 4.3026E-02 105 -106 -154 imp:n=1 u=2203 $ Zirconium Rod
2272 2 5.0820E-05 105 -106 154 -159 imp:n=1 u=2203 $ Zr/Fuel Gap
2225 119 8.9709E-02 105 -106 159 -155 imp:n=1 u=2203 $ Fuel Rod
2226 11 8.6735E-02 106 -107 -152 imp:n=1 u=2203 $ Top Graphite Reflector
2227 2 5.0820E-05 (-103:104:152) (-104:105:153) (-105:106:155)
(-106:107:152) (103 -108 -156) imp:n=1 u=2203 $ Air Gap
2228 14 8.7412E-02 102 -109 156 -157 imp:n=1 u=2203 $ Cladding
2229 14 8.7412E-02 (108 -158):(108 -109 -156) imp:n=1 u=2203 $ Top End Fitting
2230 1 9.9961E-02 157:(-102 151):(109 158) imp:n=1 u=2203 $ Water
c
c ----- SE Fuel Rod : 11771 -----
2231 14 8.7412E-02 (-103 -151):(102 -103 -156) imp:n=1 u=2204 $ Bottom End Fitting
2232 11 8.6735E-02 103 -104 -152 imp:n=1 u=2204 $ Bottom Graphite Reflector
2233 12 6.4196E-02 104 -105 -153 imp:n=1 u=2204 $ Moly Poison Disc
2234 13 4.3026E-02 105 -106 -154 imp:n=1 u=2204 $ Zirconium Rod
2273 2 5.0820E-05 105 -106 154 -159 imp:n=1 u=2204 $ Zr/Fuel Gap
2235 120 8.9275E-02 105 -106 159 -155 imp:n=1 u=2204 $ Fuel Rod
2236 11 8.6735E-02 106 -107 -152 imp:n=1 u=2204 $ Top Graphite Reflector
2237 2 5.0820E-05 (-103:104:152) (-104:105:153) (-105:106:155)
(-106:107:152) (103 -108 -156) imp:n=1 u=2204 $ Air Gap
2238 14 8.7412E-02 102 -109 156 -157 imp:n=1 u=2204 $ Cladding
2239 14 8.7412E-02 (108 -158):(108 -109 -156) imp:n=1 u=2204 $ Top End Fitting
2240 1 9.9961E-02 157:(-102 151):(109 158) imp:n=1 u=2204 $ Water
c
c ----- Fuel Assembly -----
2241 1 9.9961E-02 -5 imp:n=1 u=2200 $ Water Below Grid Plate
2243 62 7.4744E-02 5 -7 imp:n=1 u=2200 $ Grid Plate With Adapter
2244 33 7.7699E-02 7 -9 imp:n=1 u=2200 $ Lower Adapter
2245 1 9.9961E-02 -132 131 -134 133 imp:n=1 u=2205 lat=1 fill=-1:2 -1:2 0:0 $ Fuel Assemblies
2205 2205 2205 2205
2205 2203 2204 2205
2205 2201 2202 2205
2205 2205 2205 2205
2246 0 9 -10 imp:n=1 u=2200 fill=2205 (-1.9431 -1.9431 0) $ Fuel Bundle
2247 31 9.3070E-02 10 -12 imp:n=1 u=2200 $ Upper Assembly
2248 1 9.9961E-02 12 imp:n=1 u=2200 $ Water Above Core
c
c ----- Position D-5 : 4-Rod Fuel Cluster -----
c ----- NW Fuel Rod : 11790 -----
2301 14 8.7412E-02 (-103 -151):(102 -103 -156) imp:n=1 u=2301 $ Bottom End Fitting
2302 11 8.6735E-02 103 -104 -152 imp:n=1 u=2301 $ Bottom Graphite Reflector
2303 12 6.4196E-02 104 -105 -153 imp:n=1 u=2301 $ Moly Poison Disc
2304 13 4.3026E-02 105 -106 -154 imp:n=1 u=2301 $ Zirconium Rod
2370 2 5.0820E-05 105 -106 154 -159 imp:n=1 u=2301 $ Zr/Fuel Gap
2305 139 8.9600E-02 105 -106 159 -155 imp:n=1 u=2301 $ Fuel Rod
2306 11 8.6735E-02 106 -107 -152 imp:n=1 u=2301 $ Top Graphite Reflector
2307 2 5.0820E-05 (-103:104:152) (-104:105:153) (-105:106:155)
(-106:107:152) (103 -108 -156) imp:n=1 u=2301 $ Air Gap
2308 14 8.7412E-02 102 -109 156 -157 imp:n=1 u=2301 $ Cladding
2309 14 8.7412E-02 (108 -158):(108 -109 -156) imp:n=1 u=2301 $ Top End Fitting
2310 1 9.9961E-02 157:(-102 151):(109 158) imp:n=1 u=2301 $ Water
c
c ----- NE Fuel Rod : 11788 -----
2311 14 8.7412E-02 (-103 -151):(102 -103 -156) imp:n=1 u=2302 $ Bottom End Fitting
2312 11 8.6735E-02 103 -104 -152 imp:n=1 u=2302 $ Bottom Graphite Reflector
2313 12 6.4196E-02 104 -105 -153 imp:n=1 u=2302 $ Moly Poison Disc
2314 13 4.3026E-02 105 -106 -154 imp:n=1 u=2302 $ Zirconium Rod
2371 2 5.0820E-05 105 -106 154 -159 imp:n=1 u=2302 $ Zr/Fuel Gap
2315 137 8.9316E-02 105 -106 159 -155 imp:n=1 u=2302 $ Fuel Rod
2316 11 8.6735E-02 106 -107 -152 imp:n=1 u=2302 $ Top Graphite Reflector
2317 2 5.0820E-05 (-103:104:152) (-104:105:153) (-105:106:155)
(-106:107:152) (103 -108 -156) imp:n=1 u=2302 $ Air Gap
2318 14 8.7412E-02 102 -109 156 -157 imp:n=1 u=2302 $ Cladding
2319 14 8.7412E-02 (108 -158):(108 -109 -156) imp:n=1 u=2302 $ Top End Fitting
2320 1 9.9961E-02 157:(-102 151):(109 158) imp:n=1 u=2302 $ Water
c
c ----- SW Fuel Rod : 11789 -----
2321 14 8.7412E-02 (-103 -151):(102 -103 -156) imp:n=1 u=2303 $ Bottom End Fitting

```

Fundamental - FUND

NRAD-FUND-RESR-001
CRIT-REAC-COEF

```

2322 11 8.6735E-02 103 -104 -152 imp:n=1 u=2303 $ Bottom Graphite Reflector
2323 12 6.4196E-02 104 -105 -153 imp:n=1 u=2303 $ Moly Poison Disc
2324 13 4.3026E-02 105 -106 -154 imp:n=1 u=2303 $ Zirconium Rod
2372 2 5.0820E-05 105 -106 154 -159 imp:n=1 u=2303 $ Zr/Fuel Gap
2325 138 8.9487E-02 105 -106 159 -155 imp:n=1 u=2303 $ Fuel Rod
2326 11 8.6735E-02 106 -107 -152 imp:n=1 u=2303 $ Top Graphite Reflector
2327 2 5.0820E-05 (-103:104:152) (-104:105:153) (-105:106:155)
(-106:107:152) (103 -108 -156) imp:n=1 u=2303 $ Air Gap
2328 14 8.7412E-02 102 -109 156 -157 imp:n=1 u=2303 $ Cladding
2329 14 8.7412E-02 (108 -158):(108 -109 -156) imp:n=1 u=2303 $ Top End Fitting
2330 1 9.9961E-02 157:(-102 151):(109 158) imp:n=1 u=2303 $ Water
c
c ----- SE Fuel Rod : 11791 -----
2331 14 8.7412E-02 (-103 -151):(102 -103 -156) imp:n=1 u=2304 $ Bottom End Fitting
2332 11 8.6735E-02 103 -104 -152 imp:n=1 u=2304 $ Bottom Graphite Reflector
2333 12 6.4196E-02 104 -105 -153 imp:n=1 u=2304 $ Moly Poison Disc
2334 13 4.3026E-02 105 -106 -154 imp:n=1 u=2304 $ Zirconium Rod
2373 2 5.0820E-05 105 -106 154 -159 imp:n=1 u=2304 $ Zr/Fuel Gap
2335 140 8.9007E-02 105 -106 159 -155 imp:n=1 u=2304 $ Fuel Rod
2336 11 8.6735E-02 106 -107 -152 imp:n=1 u=2304 $ Top Graphite Reflector
2337 2 5.0820E-05 (-103:104:152) (-104:105:153) (-105:106:155)
(-106:107:152) (103 -108 -156) imp:n=1 u=2304 $ Air Gap
2338 14 8.7412E-02 102 -109 156 -157 imp:n=1 u=2304 $ Cladding
2339 14 8.7412E-02 (108 -158):(108 -109 -156) imp:n=1 u=2304 $ Top End Fitting
2340 1 9.9961E-02 157:(-102 151):(109 158) imp:n=1 u=2304 $ Water
c
c ----- Fuel Assembly -----
2341 1 9.9961E-02 -5 imp:n=1 u=2300 $ Water Below Grid Plate
2343 62 7.4744E-02 5 -7 imp:n=1 u=2300 $ Grid Plate With Adapter
2344 33 7.7699E-02 7 -9 imp:n=1 u=2300 $ Lower Adapter
2345 1 9.9961E-02 -132 131 -134 133 imp:n=1 u=2305 lat=1 fill=-1:2 -1:2 0:0 $ Fuel Assemblies
2305 2305 2305 2305
2305 2303 2304 2305
2305 2301 2302 2305
2305 2305 2305 2305
2346 0 9 -10 imp:n=1 u=2300 fill=2305 (-1.9431 -1.9431 0) $ Fuel Bundle
2347 31 9.3070E-02 10 -12 imp:n=1 u=2300 $ Upper Assembly
2348 1 9.9961E-02 12 imp:n=1 u=2300 $ Water Above Core
c
c ----- Position D-6 : East Beam Tube Support -----
2401 1 9.9961E-02 -5 imp:n=1 u=2400 $ Water Below Grid Plate
2403 64 7.5685E-02 5 -7 imp:n=1 u=2400 $ Grid Plate With Support
2404 51 9.1752E-02 7 -401 imp:n=1 u=2400 $ Beam Tube Support
2405 1 9.9961E-02 401 imp:n=1 u=2400 $ Water Above Support
c
c ----- Position E-1 : Graphite Reflector -----
2501 1 9.9961E-02 -5 imp:n=1 u=2500 $ Water Below Grid Plate
2503 63 6.9890E-02 5 -7 imp:n=1 u=2500 $ Grid Plate With Adapter
2504 44 7.6788E-02 7 -9 imp:n=1 u=2500 $ Lower Adapter
2505 41 7.8699E-02 (9 -10) (-9:303:354) (-9:303:355) (-9:305:351) (-306:10:356)
(-306:10:357) (331 -332 333 -334) (-335 -336 -337 -338)
imp:n=1 u=2500 $ Graphite Block
2506 42 6.0307E-02 307 -10 -356 imp:n=1 u=2500 $ Top Screw NE
2507 42 6.0307E-02 307 -10 -357 imp:n=1 u=2500 $ Top Screw SW
2508 1 9.9961E-02 306 -307 -356 imp:n=1 u=2500 $ Water in NE Top Hole
2509 1 9.9961E-02 306 -307 -357 imp:n=1 u=2500 $ Water in SW Top Hole
2510 42 6.0307E-02 9 -302 -352 imp:n=1 u=2500 $ Bottom Dowel NE
2511 42 6.0307E-02 9 -302 -353 imp:n=1 u=2500 $ Bottom Dowel SW
2512 42 6.0307E-02 9 -304 -351 imp:n=1 u=2500 $ Tie Rod
2513 1 9.9961E-02 (9 -303 352 -354):(302 -303 -354) imp:n=1 u=2500 $ Water in NE Bottom Hole
2514 1 9.9961E-02 (9 -303 353 -355):(302 -303 -355) imp:n=1 u=2500 $ Water in SW Bottom Hole
2515 1 9.9961E-02 (304 -305 -351) imp:n=1 u=2500 $ Water in Tie Rod Hole
2516 43 9.1820E-02 10 -309 imp:n=1 u=2500 $ Upper Assembly
2517 1 9.9961E-02 309 imp:n=1 u=2500 $ Water Above Core
2518 1 9.9961E-02 (9 -10) (-331:332:-333:334:335:336:337:338) imp:n=1 u=2500 $ Water Around
Assembly
c
c ----- Position E-2 : 4-Rod Fuel Cluster -----
c ----- NW Fuel Rod : 11798 -----
2601 14 8.7412E-02 (-103 -151):(102 -103 -156) imp:n=1 u=2601 $ Bottom End Fitting
2602 11 8.6735E-02 103 -104 -152 imp:n=1 u=2601 $ Bottom Graphite Reflector
2603 12 6.4196E-02 104 -105 -153 imp:n=1 u=2601 $ Moly Poison Disc
2604 13 4.3026E-02 105 -106 -154 imp:n=1 u=2601 $ Zirconium Rod
2670 2 5.0820E-05 105 -106 154 -159 imp:n=1 u=2601 $ Zr/Fuel Gap
2605 147 8.9679E-02 105 -106 159 -155 imp:n=1 u=2601 $ Fuel Rod
2606 11 8.6735E-02 106 -107 -152 imp:n=1 u=2601 $ Top Graphite Reflector

```

Fundamental - FUND

NRAD-FUND-RESR-001
CRIT-REAC-COEF

```

2607 2 5.0820E-05 (-103:104:152) (-104:105:153) (-105:106:155)
      (-106:107:152) (103 -108 -156) imp:n=1 u=2601 $ Air Gap
2608 14 8.7412E-02 102 -109 156 -157 imp:n=1 u=2601 $ Cladding
2609 14 8.7412E-02 (108 -158):(108 -109 -156) imp:n=1 u=2601 $ Top End Fitting
2610 1 9.9961E-02 157:(-102 151):(109 158) imp:n=1 u=2601 $ Water
c
c ----- NE Fuel Rod : 11796 ----- ---
2611 14 8.7412E-02 (-103 -151):(102 -103 -156) imp:n=1 u=2602 $ Bottom End Fitting
2612 11 8.6735E-02 103 -104 -152 imp:n=1 u=2602 $ Bottom Graphite Reflector
2613 12 6.4196E-02 104 -105 -153 imp:n=1 u=2602 $ Moly Poison Disc
2614 13 4.3026E-02 105 -106 -154 imp:n=1 u=2602 $ Zirconium Rod
2671 2 5.0820E-05 105 -106 154 -159 imp:n=1 u=2602 $ Zr/Fuel Gap
2615 145 8.9804E-02 105 -106 159 -155 imp:n=1 u=2602 $ Fuel Rod
2616 11 8.6735E-02 106 -107 -152 imp:n=1 u=2602 $ Top Graphite Reflector
2617 2 5.0820E-05 (-103:104:152) (-104:105:153) (-105:106:155)
      (-106:107:152) (103 -108 -156) imp:n=1 u=2602 $ Air Gap
2618 14 8.7412E-02 102 -109 156 -157 imp:n=1 u=2602 $ Cladding
2619 14 8.7412E-02 (108 -158):(108 -109 -156) imp:n=1 u=2602 $ Top End Fitting
2620 1 9.9961E-02 157:(-102 151):(109 158) imp:n=1 u=2602 $ Water
c
c ----- SW Fuel Rod : 11799 ----- ---
2621 14 8.7412E-02 (-103 -151):(102 -103 -156) imp:n=1 u=2603 $ Bottom End Fitting
2622 11 8.6735E-02 103 -104 -152 imp:n=1 u=2603 $ Bottom Graphite Reflector
2623 12 6.4196E-02 104 -105 -153 imp:n=1 u=2603 $ Moly Poison Disc
2624 13 4.3026E-02 105 -106 -154 imp:n=1 u=2603 $ Zirconium Rod
2672 2 5.0820E-05 105 -106 154 -159 imp:n=1 u=2603 $ Zr/Fuel Gap
2625 148 8.9451E-02 105 -106 159 -155 imp:n=1 u=2603 $ Fuel Rod
2626 11 8.6735E-02 106 -107 -152 imp:n=1 u=2603 $ Top Graphite Reflector
2627 2 5.0820E-05 (-103:104:152) (-104:105:153) (-105:106:155)
      (-106:107:152) (103 -108 -156) imp:n=1 u=2603 $ Air Gap
2628 14 8.7412E-02 102 -109 156 -157 imp:n=1 u=2603 $ Cladding
2629 14 8.7412E-02 (108 -158):(108 -109 -156) imp:n=1 u=2603 $ Top End Fitting
2630 1 9.9961E-02 157:(-102 151):(109 158) imp:n=1 u=2603 $ Water
c
c ----- SE Fuel Rod : 11797 ----- ---
2631 14 8.7412E-02 (-103 -151):(102 -103 -156) imp:n=1 u=2604 $ Bottom End Fitting
2632 11 8.6735E-02 103 -104 -152 imp:n=1 u=2604 $ Bottom Graphite Reflector
2633 12 6.4196E-02 104 -105 -153 imp:n=1 u=2604 $ Moly Poison Disc
2634 13 4.3026E-02 105 -106 -154 imp:n=1 u=2604 $ Zirconium Rod
2673 2 5.0820E-05 105 -106 154 -159 imp:n=1 u=2604 $ Zr/Fuel Gap
2635 146 8.9574E-02 105 -106 159 -155 imp:n=1 u=2604 $ Fuel Rod
2636 11 8.6735E-02 106 -107 -152 imp:n=1 u=2604 $ Top Graphite Reflector
2637 2 5.0820E-05 (-103:104:152) (-104:105:153) (-105:106:155)
      (-106:107:152) (103 -108 -156) imp:n=1 u=2604 $ Air Gap
2638 14 8.7412E-02 102 -109 156 -157 imp:n=1 u=2604 $ Cladding
2639 14 8.7412E-02 (108 -158):(108 -109 -156) imp:n=1 u=2604 $ Top End Fitting
2640 1 9.9961E-02 157:(-102 151):(109 158) imp:n=1 u=2604 $ Water
c
c ----- Fuel Assembly -----
2641 1 9.9961E-02 -5 imp:n=1 u=2600 $ Water Below Grid Plate
2643 62 7.4744E-02 5 -7 imp:n=1 u=2600 $ Grid Plate With Adapter
2644 33 7.7699E-02 7 -9 imp:n=1 u=2600 $ Lower Adapter
2645 1 9.9961E-02 -132 131 -134 133 imp:n=1 u=2605 lat=1 fill=-1:2 -1:2 0:0 $ Fuel Assemblies
      2605 2605 2605 2605
      2605 2603 2604 2605
      2605 2601 2602 2605
      2605 2605 2605 2605
2646 0 9 -10 imp:n=1 u=2600 fill=2605 (-1.9431 -1.9431 0) $ Fuel Bundle
2647 31 9.3070E-02 10 -12 imp:n=1 u=2600 $ Upper Assembly
2648 1 9.9961E-02 12 imp:n=1 u=2600 $ Water Above Core
c
c ----- Position E-3 : 4-Rod Fuel Cluster -----
c ----- NW Fuel Rod : 11764 ----- ---
2701 14 8.7412E-02 (-103 -151):(102 -103 -156) imp:n=1 u=2701 $ Bottom End Fitting
2702 11 8.6735E-02 103 -104 -152 imp:n=1 u=2701 $ Bottom Graphite Reflector
2703 12 6.4196E-02 104 -105 -153 imp:n=1 u=2701 $ Moly Poison Disc
2704 13 4.3026E-02 105 -106 -154 imp:n=1 u=2701 $ Zirconium Rod
2770 2 5.0820E-05 105 -106 154 -159 imp:n=1 u=2701 $ Zr/Fuel Gap
2705 113 8.9829E-02 105 -106 159 -155 imp:n=1 u=2701 $ Fuel Rod
2706 11 8.6735E-02 106 -107 -152 imp:n=1 u=2701 $ Top Graphite Reflector
2707 2 5.0820E-05 (-103:104:152) (-104:105:153) (-105:106:155)
      (-106:107:152) (103 -108 -156) imp:n=1 u=2701 $ Air Gap
2708 14 8.7412E-02 102 -109 156 -157 imp:n=1 u=2701 $ Cladding
2709 14 8.7412E-02 (108 -158):(108 -109 -156) imp:n=1 u=2701 $ Top End Fitting
2710 1 9.9961E-02 157:(-102 151):(109 158) imp:n=1 u=2701 $ Water
c

```

Fundamental - FUND

NRAD-FUND-RESR-001
CRIT-REAC-COEF

```

c ----- NE Fuel Rod : 11765 -----
2711 14 8.7412E-02 (-103 -151):(102 -103 -156) imp:n=1 u=2702 $ Bottom End Fitting
2712 11 8.6735E-02 103 -104 -152 imp:n=1 u=2702 $ Bottom Graphite Reflector
2713 12 6.4196E-02 104 -105 -153 imp:n=1 u=2702 $ Moly Poison Disc
2714 13 4.3026E-02 105 -106 -154 imp:n=1 u=2702 $ Zirconium Rod
2771 2 5.0820E-05 105 -106 154 -159 imp:n=1 u=2702 $ Zr/Fuel Gap
2715 114 8.9802E-02 105 -106 159 -155 imp:n=1 u=2702 $ Fuel Rod
2716 11 8.6735E-02 106 -107 -152 imp:n=1 u=2702 $ Top Graphite Reflector
2717 2 5.0820E-05 (-103:104:152) (-104:105:153) (-105:106:155)
(-106:107:152) (103 -108 -156) imp:n=1 u=2702 $ Air Gap
2718 14 8.7412E-02 102 -109 156 -157 imp:n=1 u=2702 $ Cladding
2719 14 8.7412E-02 (108 -158):(108 -109 -156) imp:n=1 u=2702 $ Top End Fitting
2720 1 9.9961E-02 157:(-102 151):(109 158) imp:n=1 u=2702 $ Water
c
c ----- SW Fuel Rod : 11766 -----
2721 14 8.7412E-02 (-103 -151):(102 -103 -156) imp:n=1 u=2703 $ Bottom End Fitting
2722 11 8.6735E-02 103 -104 -152 imp:n=1 u=2703 $ Bottom Graphite Reflector
2723 12 6.4196E-02 104 -105 -153 imp:n=1 u=2703 $ Moly Poison Disc
2724 13 4.3026E-02 105 -106 -154 imp:n=1 u=2703 $ Zirconium Rod
2772 2 5.0820E-05 105 -106 154 -159 imp:n=1 u=2703 $ Zr/Fuel Gap
2725 115 8.9559E-02 105 -106 159 -155 imp:n=1 u=2703 $ Fuel Rod
2726 11 8.6735E-02 106 -107 -152 imp:n=1 u=2703 $ Top Graphite Reflector
2727 2 5.0820E-05 (-103:104:152) (-104:105:153) (-105:106:155)
(-106:107:152) (103 -108 -156) imp:n=1 u=2703 $ Air Gap
2728 14 8.7412E-02 102 -109 156 -157 imp:n=1 u=2703 $ Cladding
2729 14 8.7412E-02 (108 -158):(108 -109 -156) imp:n=1 u=2703 $ Top End Fitting
2730 1 9.9961E-02 157:(-102 151):(109 158) imp:n=1 u=2703 $ Water
c
c ----- SE Fuel Rod : 11767 -----
2731 14 8.7412E-02 (-103 -151):(102 -103 -156) imp:n=1 u=2704 $ Bottom End Fitting
2732 11 8.6735E-02 103 -104 -152 imp:n=1 u=2704 $ Bottom Graphite Reflector
2733 12 6.4196E-02 104 -105 -153 imp:n=1 u=2704 $ Moly Poison Disc
2734 13 4.3026E-02 105 -106 -154 imp:n=1 u=2704 $ Zirconium Rod
2773 2 5.0820E-05 105 -106 154 -159 imp:n=1 u=2704 $ Zr/Fuel Gap
2735 116 8.9156E-02 105 -106 159 -155 imp:n=1 u=2704 $ Fuel Rod
2736 11 8.6735E-02 106 -107 -152 imp:n=1 u=2704 $ Top Graphite Reflector
2737 2 5.0820E-05 (-103:104:152) (-104:105:153) (-105:106:155)
(-106:107:152) (103 -108 -156) imp:n=1 u=2704 $ Air Gap
2738 14 8.7412E-02 102 -109 156 -157 imp:n=1 u=2704 $ Cladding
2739 14 8.7412E-02 (108 -158):(108 -109 -156) imp:n=1 u=2704 $ Top End Fitting
2740 1 9.9961E-02 157:(-102 151):(109 158) imp:n=1 u=2704 $ Water
c
c ----- Fuel Assembly -----
2741 1 9.9961E-02 -5 imp:n=1 u=2700 $ Water Below Grid Plate
2743 62 7.4744E-02 5 -7 imp:n=1 u=2700 $ Grid Plate With Adapter
2744 33 7.7699E-02 7 -9 imp:n=1 u=2700 $ Lower Adapter
2745 1 9.9961E-02 -132 131 -134 133 imp:n=1 u=2705 lat=1 fill=-1:2 -1:2 0:0 $ Fuel Assemblies
2705 2705 2705 2705
2705 2703 2704 2705
2705 2701 2702 2705
2705 2705 2705 2705
2746 0 9 -10 imp:n=1 u=2700 fill=2705 (-1.9431 -1.9431 0) $ Fuel Bundle
2747 31 9.3070E-02 10 -12 imp:n=1 u=2700 $ Upper Assembly
2748 1 9.9961E-02 12 imp:n=1 u=2700 $ Water Above Core
c
c ----- Position E-4 : Regulating Rod Control Cluster -----
c ----- NW Fuel Rod : 11758 -----
2801 14 8.7412E-02 (-103 -151):(102 -103 -156) imp:n=1 u=2801 $ Bottom End Fitting
2802 11 8.6735E-02 103 -104 -152 imp:n=1 u=2801 $ Bottom Graphite Reflector
2803 12 6.4196E-02 104 -105 -153 imp:n=1 u=2801 $ Moly Poison Disc
2804 13 4.3026E-02 105 -106 -154 imp:n=1 u=2801 $ Zirconium Rod
2870 2 5.0820E-05 105 -106 154 -159 imp:n=1 u=2801 $ Zr/Fuel Gap
2805 107 8.9626E-02 105 -106 159 -155 imp:n=1 u=2801 $ Fuel Rod
2806 11 8.6735E-02 106 -107 -152 imp:n=1 u=2801 $ Top Graphite Reflector
2807 2 5.0820E-05 (-103:104:152) (-104:105:153) (-105:106:155)
(-106:107:152) (103 -108 -156) imp:n=1 u=2801 $ Air Gap
2808 14 8.7412E-02 102 -109 156 -157 imp:n=1 u=2801 $ Cladding
2809 14 8.7412E-02 (108 -158):(108 -109 -156) imp:n=1 u=2801 $ Top End Fitting
2810 1 9.9961E-02 157:(-102 151):(109 158) imp:n=1 u=2801 $ Water
c
c ----- NE Control Rod : Reg -----
2811 14 8.7412E-02 -201 -251 imp:n=1 u=2802 $ Bottom End Fitting
2812 23 6.7723E-02 201 -202 -253 imp:n=1 u=2802 $ Guide Tube Bottom
2813 25 6.1351E-02 202 -203 252 -253 imp:n=1 u=2802 $ Guide Tube
2814 1 9.9961E-02 (-201 251):253:(203 252) imp:n=1 u=2802 $ Water Outside Guide Tube
c

```

Fundamental - FUND

NRAD-FUND-RESR-001
CRIT-REAC-COEF

```

2850 22 5.9939E-02 231 -232 -275 imp:n=1 u=2806 $ Bottom End Fitting
2851 21 1.3514E-01 232 -233 -271 imp:n=1 u=2806 $ Absorber
2852 22 5.9939E-02 233 -234 272 -271 imp:n=1 u=2806 $ Spacer Disc
2853 22 5.9939E-02 234 -235 273 -274 imp:n=1 u=2806 $ Spacer Tube
2854 0 (232 -234 271 -275):(233 -234 -272):(234 -235 -273):(234 -235 274 -275)
      imp:n=1 u=2806 $ Void Space
2855 22 5.9939E-02 (235 -236 -275):(236 -237 -277) imp:n=1 u=2806 $ Top End Fitting
2856 22 5.9939E-02 231 -236 275 -276 imp:n=1 u=2806 $ Cladding
2857 24 6.8709E-02 237 -238 -278 imp:n=1 u=2806 $ Attachment Interface
2858 2 5.0820E-05 238 -239 -279 imp:n=1 u=2806 $ Inside Extension Rod
2859 22 5.9939E-02 238 -239 279 -280 imp:n=1 u=2806 $ Extension Rod
2860 1 9.9961E-02 (-231 -276):(276):(236 278):(238 280):(236 -237 277):(239)
      imp:n=1 u=2806 $ Water around Control Rod
c
c ----- SW Fuel Rod : 11759 -----
2821 14 8.7412E-02 (-103 -151):(102 -103 -156) imp:n=1 u=2803 $ Bottom End Fitting
2822 11 8.6735E-02 103 -104 -152 imp:n=1 u=2803 $ Bottom Graphite Reflector
2823 12 6.4196E-02 104 -105 -153 imp:n=1 u=2803 $ Moly Poison Disc
2824 13 4.3026E-02 105 -106 -154 imp:n=1 u=2803 $ Zirconium Rod
2872 2 5.0820E-05 105 -106 154 -159 imp:n=1 u=2803 $ Zr/Fuel Gap
2825 108 8.9895E-02 105 -106 159 -155 imp:n=1 u=2803 $ Fuel Rod
2826 11 8.6735E-02 106 -107 -152 imp:n=1 u=2803 $ Top Graphite Reflector
2827 2 5.0820E-05 (-103:104:152) (-104:105:153) (-105:106:155)
      (-106:107:152) (103 -108 -156) imp:n=1 u=2803 $ Air Gap
2828 14 8.7412E-02 102 -109 156 -157 imp:n=1 u=2803 $ Cladding
2829 14 8.7412E-02 (108 -158):(108 -109 -156) imp:n=1 u=2803 $ Top End Fitting
2830 1 9.9961E-02 157:(-102 151):(109 158) imp:n=1 u=2803 $ Water
c
c ----- SE Fuel Rod : 11760 -----
2831 14 8.7412E-02 (-103 -151):(102 -103 -156) imp:n=1 u=2804 $ Bottom End Fitting
2832 11 8.6735E-02 103 -104 -152 imp:n=1 u=2804 $ Bottom Graphite Reflector
2833 12 6.4196E-02 104 -105 -153 imp:n=1 u=2804 $ Moly Poison Disc
2834 13 4.3026E-02 105 -106 -154 imp:n=1 u=2804 $ Zirconium Rod
2873 2 5.0820E-05 105 -106 154 -159 imp:n=1 u=2804 $ Zr/Fuel Gap
2835 109 8.9164E-02 105 -106 159 -155 imp:n=1 u=2804 $ Fuel Rod
2836 11 8.6735E-02 106 -107 -152 imp:n=1 u=2804 $ Top Graphite Reflector
2837 2 5.0820E-05 (-103:104:152) (-104:105:153) (-105:106:155)
      (-106:107:152) (103 -108 -156) imp:n=1 u=2804 $ Air Gap
2838 14 8.7412E-02 102 -109 156 -157 imp:n=1 u=2804 $ Cladding
2839 14 8.7412E-02 (108 -158):(108 -109 -156) imp:n=1 u=2804 $ Top End Fitting
2840 1 9.9961E-02 157:(-102 151):(109 158) imp:n=1 u=2804 $ Water
c
c ----- Fuel Assembly -----
2841 1 9.9961E-02 -5 imp:n=1 u=2800 $ Water Below Grid Plate
2843 62 7.4744E-02 5 -7 imp:n=1 u=2800 $ Grid Plate With Adapter
2844 33 7.7699E-02 7 -9 imp:n=1 u=2800 $ Lower Adapter
2845 1 9.9961E-02 -132 131 -134 133 imp:n=1 u=2805 lat=1 fill=-1:2 -1:2 0:0 $ Fuel Assemblies
      2805 2805 2805 2805
      2805 2803 2804 2805
      2805 2801 2802 2805
      2805 2805 2805 2805
2846 0 9 -10 imp:n=1 u=2800 fill=2805 (-1.9431 -1.9431 0) $ Fuel Bundle
2847 32 9.1839E-02 10 -12 262 imp:n=1 u=2800 $ Upper Assembly
2848 1 9.9961E-02 12 262 imp:n=1 u=2800 $ Water Above Core
2849 0 10 -262 imp:n=1 u=2800 fill=2805 (-1.9431 -1.9431 0)
c
c ----- Position E-5 : 4-Rod Fuel Cluster -----
c ----- NW Fuel Rod : 11804 -----
2901 14 8.7412E-02 (-103 -151):(102 -103 -156) imp:n=1 u=2901 $ Bottom End Fitting
2902 11 8.6735E-02 103 -104 -152 imp:n=1 u=2901 $ Bottom Graphite Reflector
2903 12 6.4196E-02 104 -105 -153 imp:n=1 u=2901 $ Moly Poison Disc
2904 13 4.3026E-02 105 -106 -154 imp:n=1 u=2901 $ Zirconium Rod
2970 2 5.0820E-05 105 -106 154 -159 imp:n=1 u=2901 $ Zr/Fuel Gap
2905 153 8.9001E-02 105 -106 159 -155 imp:n=1 u=2901 $ Fuel Rod
2906 11 8.6735E-02 106 -107 -152 imp:n=1 u=2901 $ Top Graphite Reflector
2907 2 5.0820E-05 (-103:104:152) (-104:105:153) (-105:106:155)
      (-106:107:152) (103 -108 -156) imp:n=1 u=2901 $ Air Gap
2908 14 8.7412E-02 102 -109 156 -157 imp:n=1 u=2901 $ Cladding
2909 14 8.7412E-02 (108 -158):(108 -109 -156) imp:n=1 u=2901 $ Top End Fitting
2910 1 9.9961E-02 157:(-102 151):(109 158) imp:n=1 u=2901 $ Water
c
c ----- NE Fuel Rod : 11806 -----
2911 14 8.7412E-02 (-103 -151):(102 -103 -156) imp:n=1 u=2902 $ Bottom End Fitting
2912 11 8.6735E-02 103 -104 -152 imp:n=1 u=2902 $ Bottom Graphite Reflector
2913 12 6.4196E-02 104 -105 -153 imp:n=1 u=2902 $ Moly Poison Disc
2914 13 4.3026E-02 105 -106 -154 imp:n=1 u=2902 $ Zirconium Rod

```

Fundamental - FUND

NRAD-FUND-RESR-001
CRIT-REAC-COEF

```

2971 2 5.0820E-05 105 -106 154 -159 imp:n=1 u=2902 $ Zr/Fuel Gap
2915 155 8.9409E-02 105 -106 159 -155 imp:n=1 u=2902 $ Fuel Rod
2916 11 8.6735E-02 106 -107 -152 imp:n=1 u=2902 $ Top Graphite Reflector
2917 2 5.0820E-05 (-103:104:152) (-104:105:153) (-105:106:155)
(-106:107:152) (103 -108 -156) imp:n=1 u=2902 $ Air Gap
2918 14 8.7412E-02 102 -109 156 -157 imp:n=1 u=2902 $ Cladding
2919 14 8.7412E-02 (108 -158):(108 -109 -156) imp:n=1 u=2902 $ Top End Fitting
2920 1 9.9961E-02 157:(-102 151):(109 158) imp:n=1 u=2902 $ Water
c
c ----- SW Fuel Rod : 11805 -----
2921 14 8.7412E-02 (-103 -151):(102 -103 -156) imp:n=1 u=2903 $ Bottom End Fitting
2922 11 8.6735E-02 103 -104 -152 imp:n=1 u=2903 $ Bottom Graphite Reflector
2923 12 6.4196E-02 104 -105 -153 imp:n=1 u=2903 $ Moly Poison Disc
2924 13 4.3026E-02 105 -106 -154 imp:n=1 u=2903 $ Zirconium Rod
2972 2 5.0820E-05 105 -106 154 -159 imp:n=1 u=2903 $ Zr/Fuel Gap
2925 154 8.9470E-02 105 -106 159 -155 imp:n=1 u=2903 $ Fuel Rod
2926 11 8.6735E-02 106 -107 -152 imp:n=1 u=2903 $ Top Graphite Reflector
2927 2 5.0820E-05 (-103:104:152) (-104:105:153) (-105:106:155)
(-106:107:152) (103 -108 -156) imp:n=1 u=2903 $ Air Gap
2928 14 8.7412E-02 102 -109 156 -157 imp:n=1 u=2903 $ Cladding
2929 14 8.7412E-02 (108 -158):(108 -109 -156) imp:n=1 u=2903 $ Top End Fitting
2930 1 9.9961E-02 157:(-102 151):(109 158) imp:n=1 u=2903 $ Water
c
c ----- SE Fuel Rod : 11807 -----
2931 14 8.7412E-02 (-103 -151):(102 -103 -156) imp:n=1 u=2904 $ Bottom End Fitting
2932 11 8.6735E-02 103 -104 -152 imp:n=1 u=2904 $ Bottom Graphite Reflector
2933 12 6.4196E-02 104 -105 -153 imp:n=1 u=2904 $ Moly Poison Disc
2934 13 4.3026E-02 105 -106 -154 imp:n=1 u=2904 $ Zirconium Rod
2973 2 5.0820E-05 105 -106 154 -159 imp:n=1 u=2904 $ Zr/Fuel Gap
2935 156 8.9534E-02 105 -106 159 -155 imp:n=1 u=2904 $ Fuel Rod
2936 11 8.6735E-02 106 -107 -152 imp:n=1 u=2904 $ Top Graphite Reflector
2937 2 5.0820E-05 (-103:104:152) (-104:105:153) (-105:106:155)
(-106:107:152) (103 -108 -156) imp:n=1 u=2904 $ Air Gap
2938 14 8.7412E-02 102 -109 156 -157 imp:n=1 u=2904 $ Cladding
2939 14 8.7412E-02 (108 -158):(108 -109 -156) imp:n=1 u=2904 $ Top End Fitting
2940 1 9.9961E-02 157:(-102 151):(109 158) imp:n=1 u=2904 $ Water
c
c ----- Fuel Assembly -----
2941 1 9.9961E-02 -5 imp:n=1 u=2900 $ Water Below Grid Plate
2943 62 7.4744E-02 5 -7 imp:n=1 u=2900 $ Grid Plate With Adapter
2944 33 7.7699E-02 7 -9 imp:n=1 u=2900 $ Lower Adapter
2945 1 9.9961E-02 -132 131 -134 133 imp:n=1 u=2905 lat=1 fill=-1:2 -1:2 0:0 $ Fuel Assemblies
2905 2905 2905 2905
2905 2903 2904 2905
2905 2901 2902 2905
2905 2905 2905 2905
2946 0 9 -10 imp:n=1 u=2900 fill=2905 (-1.9431 -1.9431 0) $ Fuel Bundle
2947 31 9.3070E-02 10 -12 imp:n=1 u=2900 $ Upper Assembly
2948 1 9.9961E-02 12 imp:n=1 u=2900 $ Water Above Core
c
c ----- Position E-6 : Graphite Reflector -----
3001 1 9.9961E-02 -5 imp:n=1 u=3000 $ Water Below Grid Plate
3003 63 6.9890E-02 5 -7 imp:n=1 u=3000 $ Grid Plate With Adapter
3004 44 7.6788E-02 7 -9 imp:n=1 u=3000 $ Lower Adapter
3005 41 7.8699E-02 (9 -10) (-9:303:354) (-9:303:355) (-9:305:351) (-306:10:356)
(-306:10:357) (331 -332 333 -334) (-335 -336 -337 -338)
imp:n=1 u=3000 $ Graphite Block
3006 42 6.0307E-02 307 -10 -356 imp:n=1 u=3000 $ Top Screw NE
3007 42 6.0307E-02 307 -10 -357 imp:n=1 u=3000 $ Top Screw SW
3008 1 9.9961E-02 306 -307 -356 imp:n=1 u=3000 $ Water in NE Top Hole
3009 1 9.9961E-02 306 -307 -357 imp:n=1 u=3000 $ Water in SW Top Hole
3010 42 6.0307E-02 9 -302 -352 imp:n=1 u=3000 $ Bottom Dowel NE
3011 42 6.0307E-02 9 -302 -353 imp:n=1 u=3000 $ Bottom Dowel SW
3012 42 6.0307E-02 9 -304 -351 imp:n=1 u=3000 $ Tie Rod
3013 1 9.9961E-02 (9 -303 352 -354):(302 -303 -354) imp:n=1 u=3000 $ Water in NE Bottom Hole
3014 1 9.9961E-02 (9 -303 353 -355):(302 -303 -355) imp:n=1 u=3000 $ Water in SW Bottom Hole
3015 1 9.9961E-02 (304 -305 -351) imp:n=1 u=3000 $ Water in Tie Rod Hole
3016 43 9.1820E-02 10 -309 imp:n=1 u=3000 $ Upper Assembly
3017 1 9.9961E-02 309 imp:n=1 u=3000 $ Water Above Core
3018 1 9.9961E-02 (9 -10) (-331:332:-333:334:335:336:337:338) imp:n=1 u=3000 $ Water Around
Assembly
c
c ----- Position F-1 : Empty Position -----
3101 1 9.9961E-02 -5 imp:n=1 u=3100 $ Water Below Grid Plate
3102 61 8.0867E-02 5 -7 imp:n=1 u=3100 $ Empty Grid Plate Position
3103 1 9.9961E-02 7 imp:n=1 u=3100 $ Water Above Core

```

Fundamental - FUND

NRAD-FUND-RESR-001
CRIT-REAC-COEF

```

c
c ----- Position F-2 : Graphite Reflector -----
3201 1 9.9961E-02 -5 imp:n=1 u=3200 $ Water Below Grid Plate
3203 63 6.9890E-02 5 -7 imp:n=1 u=3200 $ Grid Plate With Adapter
3204 44 7.6788E-02 7 -9 imp:n=1 u=3200 $ Lower Adapter
3205 41 7.8699E-02 (9 -10) (-9:303:354) (-9:303:355) (-9:305:351) (-306:10:356)
(-306:10:357) (331 -332 333 -334) (-335 -336 -337 -338)
imp:n=1 u=3200 $ Graphite Block
3206 42 6.0307E-02 307 -10 -356 imp:n=1 u=3200 $ Top Screw NE
3207 42 6.0307E-02 307 -10 -357 imp:n=1 u=3200 $ Top Screw SW
3208 1 9.9961E-02 306 -307 -356 imp:n=1 u=3200 $ Water in NE Top Hole
3209 1 9.9961E-02 306 -307 -357 imp:n=1 u=3200 $ Water in SW Top Hole
3210 42 6.0307E-02 9 -302 -352 imp:n=1 u=3200 $ Bottom Dowel NE
3211 42 6.0307E-02 9 -302 -353 imp:n=1 u=3200 $ Bottom Dowel SW
3212 42 6.0307E-02 9 -304 -351 imp:n=1 u=3200 $ Tie Rod
3213 1 9.9961E-02 (9 -303 352 -354):(302 -303 -354) imp:n=1 u=3200 $ Water in NE Bottom Hole
3214 1 9.9961E-02 (9 -303 353 -355):(302 -303 -355) imp:n=1 u=3200 $ Water in SW Bottom Hole
3215 1 9.9961E-02 (304 -305 -351) imp:n=1 u=3200 $ Water in Tie Rod Hole
3216 43 9.1820E-02 10 -309 imp:n=1 u=3200 $ Upper Assembly
3217 1 9.9961E-02 309 imp:n=1 u=3200 $ Water Above Core
3218 1 9.9961E-02 (9 -10) (-331:332:-333:334:335:336:337:338) imp:n=1 u=3200 $ Water Around
Assembly
c
c ----- Position F-3 : Graphite Reflector (AmBe Source) -----
3301 1 9.9961E-02 -5 imp:n=1 u=3300 $ Water Below Grid Plate
3303 63 6.9890E-02 5 -7 imp:n=1 u=3300 $ Grid Plate With Adapter
3304 44 7.6788E-02 7 -9 imp:n=1 u=3300 $ Lower Adapter
3305 41 7.8699E-02 (9 -10) (-9:303:354) (-9:303:355) (-9:305:351) (-306:10:356)
(-306:10:357) (331 -332 333 -334) (-335 -336 -337 -338)
(-321:322:372) (341:376) (-322:371) imp:n=1 u=3300 $ Graphite Block
3306 42 6.0307E-02 307 -10 -356 imp:n=1 u=3300 $ Top Screw NE
3307 42 6.0307E-02 307 -10 -357 imp:n=1 u=3300 $ Top Screw SW
3308 1 9.9961E-02 306 -307 -356 imp:n=1 u=3300 $ Water in NE Top Hole
3309 1 9.9961E-02 306 -307 -357 imp:n=1 u=3300 $ Water in SW Top Hole
3310 42 6.0307E-02 9 -302 -352 imp:n=1 u=3300 $ Bottom Dowel NE
3311 42 6.0307E-02 9 -302 -353 imp:n=1 u=3300 $ Bottom Dowel SW
3312 42 6.0307E-02 9 -304 -351 imp:n=1 u=3300 $ Tie Rod
3313 1 9.9961E-02 (9 -303 352 -354):(302 -303 -354) imp:n=1 u=3300 $ Water in NE Bottom Hole
3314 1 9.9961E-02 (9 -303 353 -355):(302 -303 -355) imp:n=1 u=3300 $ Water in SW Bottom Hole
3315 1 9.9961E-02 (304 -305 -351) imp:n=1 u=3300 $ Water in Tie Rod Hole
3316 47 9.0981E-02 10 -309 375 imp:n=1 u=3300 $ Upper Assembly
3317 1 9.9961E-02 309 imp:n=1 u=3300 $ Water Above Core
3318 1 9.9961E-02 (9 -10) (-331:332:-333:334:335:336:337:338) imp:n=1 u=3300 $ Water Around
Assembly
c
3331 1 9.9961E-02 (-341 333 -376):(321 -322 -372):(373 -371 322 -324)
imp:n=1 u=3300 $ Water in Source Hole
3332 22 5.9939E-02 ((-323:325:374) 322 -326 -373 (-322:323:372) (341:377))
:(326 -327 342 -343 344 -345):(324 -326 -375 373)
imp:n=1 u=3300 $ Source Tube
3333 1 9.9961E-02 ((-341 -371 -377):(322 -323 -372):(323 -325 -374))
(-323:313:362):(10 -324 371 -375) imp:n=1 u=3300 $ Water in Source Tube
3334 1 9.9961E-02 (-326:327:-342:343:-344:345) 326 -309 -375 imp:n=1 u=3300 $ Water Above Source
Tube
3335 46 8.7653E-02 (-311:312:361) 323 -313 -362 imp:n=1 u=3300 $ Source Capsule
3336 45 4.1093E-03 311 -312 -361 imp:n=1 u=3300 $ Smearred AmBe Source
c
c ----- Position F-4 : Graphite Reflector -----
3401 1 9.9961E-02 -5 imp:n=1 u=3400 $ Water Below Grid Plate
3403 63 6.9890E-02 5 -7 imp:n=1 u=3400 $ Grid Plate With Adapter
3404 44 7.6788E-02 7 -9 imp:n=1 u=3400 $ Lower Adapter
3405 41 7.8699E-02 (9 -10) (-9:303:354) (-9:303:355) (-9:305:351) (-306:10:356)
(-306:10:357) (331 -332 333 -334) (-335 -336 -337 -338)
imp:n=1 u=3400 $ Graphite Block
3406 42 6.0307E-02 307 -10 -356 imp:n=1 u=3400 $ Top Screw NE
3407 42 6.0307E-02 307 -10 -357 imp:n=1 u=3400 $ Top Screw SW
3408 1 9.9961E-02 306 -307 -356 imp:n=1 u=3400 $ Water in NE Top Hole
3409 1 9.9961E-02 306 -307 -357 imp:n=1 u=3400 $ Water in SW Top Hole
3410 42 6.0307E-02 9 -302 -352 imp:n=1 u=3400 $ Bottom Dowel NE
3411 42 6.0307E-02 9 -302 -353 imp:n=1 u=3400 $ Bottom Dowel SW
3412 42 6.0307E-02 9 -304 -351 imp:n=1 u=3400 $ Tie Rod
3413 1 9.9961E-02 (9 -303 352 -354):(302 -303 -354) imp:n=1 u=3400 $ Water in NE Bottom Hole
3414 1 9.9961E-02 (9 -303 353 -355):(302 -303 -355) imp:n=1 u=3400 $ Water in SW Bottom Hole
3415 1 9.9961E-02 (304 -305 -351) imp:n=1 u=3400 $ Water in Tie Rod Hole
3416 43 9.1820E-02 10 -309 imp:n=1 u=3400 $ Upper Assembly
3417 1 9.9961E-02 309 imp:n=1 u=3400 $ Water Above Core

```

Fundamental - FUND

NRAD-FUND-RESR-001
CRIT-REAC-COEF

```

3418 1 9.9961E-02 (9 -10) (-331:332:-333:334:335:336:337:338) imp:n=1 u=3400 $ Water Around
Assembly
c
c ----- Position F-5 : Graphite Reflector -----
3501 1 9.9961E-02 -5 imp:n=1 u=3500 $ Water Below Grid Plate
3503 63 6.9890E-02 5 -7 imp:n=1 u=3500 $ Grid Plate With Adapter
3504 44 7.6788E-02 7 -9 imp:n=1 u=3500 $ Lower Adapter
3505 41 7.8699E-02 (9 -10) (-9:303:354) (-9:303:355) (-9:305:351) (-306:10:356)
(-306:10:357) (331 -332 333 -334) (-335 -336 -337 -338)
imp:n=1 u=3500 $ Graphite Block
3506 42 6.0307E-02 307 -10 -356 imp:n=1 u=3500 $ Top Screw NE
3507 42 6.0307E-02 307 -10 -357 imp:n=1 u=3500 $ Top Screw SW
3508 1 9.9961E-02 306 -307 -356 imp:n=1 u=3500 $ Water in NE Top Hole
3509 1 9.9961E-02 306 -307 -357 imp:n=1 u=3500 $ Water in SW Top Hole
3510 42 6.0307E-02 9 -302 -352 imp:n=1 u=3500 $ Bottom Dowel NE
3511 42 6.0307E-02 9 -302 -353 imp:n=1 u=3500 $ Bottom Dowel SW
3512 42 6.0307E-02 9 -304 -351 imp:n=1 u=3500 $ Tie Rod
3513 1 9.9961E-02 (9 -303 352 -354):(302 -303 -354) imp:n=1 u=3500 $ Water in NE Bottom Hole
3514 1 9.9961E-02 (9 -303 353 -355):(302 -303 -355) imp:n=1 u=3500 $ Water in SW Bottom Hole
3515 1 9.9961E-02 (304 -305 -351) imp:n=1 u=3500 $ Water in Tie Rod Hole
3516 43 9.1820E-02 10 -309 imp:n=1 u=3500 $ Upper Assembly
3517 1 9.9961E-02 309 imp:n=1 u=3500 $ Water Above Core
3518 1 9.9961E-02 (9 -10) (-331:332:-333:334:335:336:337:338) imp:n=1 u=3500 $ Water Around
Assembly
c
c ----- Position F-6 : Empty Position -----
3601 1 9.9961E-02 -5 imp:n=1 u=3600 $ Water Below Grid Plate
3602 61 8.0867E-02 5 -7 imp:n=1 u=3600 $ Empty Grid Plate Position
3603 1 9.9961E-02 7 imp:n=1 u=3600 $ Water Above Core
c
c --- Beam Lines -----
c ----- East Beam Line -----
3701 2 5.0820E-05 (404 -405 436 -437 435 -434):(434 -442 -601) imp:n=1 $ Air in Beam Filter
Tube
3702 52 5.9939E-02 (-404:405:-436:437:-435) 402 -403 432 -433 431 -434 imp:n=1 $ Beam Filter
Tube
3703 52 5.9939E-02 (-402:403:-432:433:434) (438 -447 439 -440 406 -407)
(601:442) (-441:-445:446) imp:n=1 $ Beam Filter Tube Attachment Fixtures
3704 52 5.9939E-02 441 -444 445 -446 408 -13 (-447:448:-449:450:-409)
(601:-443:447) (602:-448:451) imp:n=1 $ Beam Aperture Housing
3705 53 1.2258E-06 ((447 -448 449 -450 409 -13):(443 -447 -601):
(448 -451 -602)) (-410:413:-459:448:-455:456) imp:n=1 $ Helium in Aperture
Housing
3706 54 1.0026E-01 444 -452 631 -632 imp:n=1 $ Absorber Disc Aperture
3707 53 1.2258E-06 444 -452 -631 imp:n=1 $ Helium in Disc Aperture
3708 52 5.9939E-02 452 -454 -606 (603:-453) imp:n=1 $ Beam Stop
3709 53 1.2258E-06 -633 459 -448 imp:n=1 $ Helium in Bottom Aperture Hole
3710 53 1.2258E-06 -634 459 -448 imp:n=1 $ Helium in Top Aperture Hole
3711 54 1.0026E-01 460 -461 457 -458 411 -412 633 634 imp:n=1 $ Absorber Aperture Block
3712 52 5.9939E-02 (-460:461:-457:458:-411:412) 459 -448 455 -456 410 -413
633 634 imp:n=1 $ Absorber Assembly Housing
c
3770 52 5.9939E-02 (444 604 -605 -71):((444:-445:446) 448 -444 -605) imp:n=1 $ Beam Tube
3771 53 1.2258E-06 444 -604 -71 (-444:452:632) (-452:454:606) : (453 -454 -603)
imp:n=1 $ Helium in Beam Tube
c
c ----- North Beam Line -----
3801 53 1.2258E-06 (404 -405 536 -537 535 -534):(534 -542 -651) imp:n=1 $ Helium in Beam Filter
Tube
3802 52 5.9939E-02 (-404:405:-536:537:-535) 402 -403 532 -533 531 -534 imp:n=1 $ Beam Filter
Tube
3803 52 5.9939E-02 (-402:403:-532:533:534) (538 -547 539 -540 406 -407)
(651:542) (-541:-545:546) imp:n=1 $ Beam Filter Tube Attachment Fixtures
3804 52 5.9939E-02 541 -544 545 -546 408 -13 (-547:548:-549:550:-409)
(651:-543:547) (652:-548:551) imp:n=1 $ Beam Aperture Housing
3805 53 1.2258E-06 ((547 -548 549 -550 409 -13):(543 -547 -651):
(548 -551 -652)) (-410:413:-559:548:-555:556) imp:n=1 $ Helium in Aperture
Housing
3806 54 1.0026E-01 544 -552 671 -672 imp:n=1 $ Absorber Disc Aperture
3807 53 1.2258E-06 544 -552 -671 imp:n=1 $ Helium in Disc Aperture
3808 52 5.9939E-02 552 -554 -656 (653:-553) imp:n=1 $ Beam Stop
3809 53 1.2258E-06 -673 559 -548 imp:n=1 $ Helium in Bottom Aperture Hole
3810 53 1.2258E-06 -674 559 -548 imp:n=1 $ Helium in Top Aperture Hole
3811 54 1.0026E-01 560 -561 557 -558 411 -412 673 674 imp:n=1 $ Absorber Aperture Block
3812 52 5.9939E-02 (-560:561:-557:558:-411:412) 559 -548 555 -556 410 -413
673 674 imp:n=1 $ Absorber Assembly Housing

```

Fundamental - FUND

NRAD-FUND-RESR-001
CRIT-REAC-COEF

```

c
3870 52 5.9939E-02 (544 654 -655 -71):((544:-545:546) 548 -544 -655) imp:n=1 $ Beam Tube
3871 53 1.2258E-06 544 -654 -71 (-544:552:672) (-552:554:656)
      : (553 -554 -653) imp:n=1 $ Helium in Beam Tube
c
c --- NRAD Reactor Core -----
c ----- Core Map -----
3901 1 9.9961E-02 -32 31 -34 33 imp:n=1 u=3900 lat=1 fill=-4:5 -4:5 0:0
      3900 3900 3900 3900 3900 3900 3900 3900 3900 3900 3900
      3900 3100 3100 3100 3100 3600 3600 3600 3600 3900
      3900 3100 3100 3200 3300 3400 3500 3600 3600 3900
      3900 3100 2500 2600 2700 2800 2900 3000 3600 3900
      3900 3100 1900 2000 2100 2200 2300 2400 3600 3900
      3900 100 1300 1400 1500 1600 1700 1800 600 3900
      3900 100 700 800 900 1000 1100 1200 600 3900
      3900 100 100 200 300 400 500 600 600 3900
      3900 100 100 100 100 600 600 600 600 3900
      3900 3900 3900 3900 3900 3900 3900 3900 3900 3900
c
c ----- Core Map Legend -----
c      H2O H2O H2O H2O H2O H2O H2O H2O H2O H2O
c      H2O Grid Grid Grid Grid Grid Grid Grid Grid Grid H2O
c      H2O Grid Grid Grph Srce Grph Grph Grid Grid H2O
c      H2O Grid Grph Fuel Fuel Reg Fuel Grph Grid H2O
c      H2O Grid Grph Shm1 Fuel Fuel Fuel EaBm Grid H2O
c      H2O Grid Grph Shm2 Fuel Hole Fuel EaBm Grid H2O
c      H2O Grid Grph Fuel Fuel Fuel Fuel Grph Grid H2O
c      H2O Grid Grid Grph NoBm NoBm Grph Grid Grid H2O
c      H2O Grid Grid Grid Grid Grid Grid Grid Grid Grid H2O
c      H2O H2O H2O H2O H2O H2O H2O H2O H2O H2O
c
c      EaBm = East Beam Support
c      Fuel = Four Fuel Cluster
c      Grid = Empty Grid Position (or Grid Edge)
c      Grph = Graphite Block Reflector
c      H2O = Water
c      Hole = Water Hole (Irradiation Position)
c      NoBm = North Beam Support
c      Reg = Regulating Rod Cluster
c      Shm1 = Shim Rod 1 Cluster
c      Shm2 = Shim Rod 2 Cluster
c      Srce = Graphite Block Reflector with AmBe Source
c
c ----- Core Map Positions -----
c      H2O H2O H2O H2O H2O H2O H2O H2O H2O H2O
c      H2O Grid Grid Grid Grid Grid Grid Grid Grid Grid H2O
c      H2O Grid F-1 F-2 F-3 F-4 F-5 F-6 Grid H2O
c      H2O Grid E-1 E-2 E-3 E-4 E-5 E-6 Grid H2O
c      H2O Grid D-1 D-2 D-3 D-4 D-5 D-6 Grid H2O
c      H2O Grid C-1 C-2 C-3 C-4 C-5 C-6 Grid H2O
c      H2O Grid B-1 B-2 B-3 B-4 B-5 B-6 Grid H2O
c      H2O Grid A-1 A-2 A-3 A-4 A-5 A-6 Grid H2O
c      H2O Grid Grid Grid Grid Grid Grid Grid Grid Grid H2O
c      H2O H2O H2O H2O H2O H2O H2O H2O H2O H2O
c
c      Note: Visual Core Map is Mirrored Vertically Compared to Actual Positions
c
3902 0 (-36 35 -38 37 -13 3) (-402:403:-532:533:-531) (-402:403:-432:433:-431)
      imp:n=1 fill=3900 (-4.05003 -3.85445 0)
c
c --- Ex-Core Components -----
4001 65 8.2064E-02 (3 -6 -40 39 -42 41) (36:-35:38:-37) imp:n=1 $ Support Structure
4002 1 9.9961E-02 (6 -13 -40 39 -42 41) (36:-35:38:-37)
      (-402:403:-532:533:-531) (-402:403:-432:433:-431) imp:n=1 $ Water Above Support
structure
c
4011 66 5.9939E-02 2 -3 -71 imp:n=1 $ Mounting Pad
c
4021 66 5.9939E-02 1 -13 -72 (-2:71) imp:n=1 $ Tank
c
c ----- Tank Water -----
4101 1 9.9961E-02 (40:-39:42:-41) (3 -13 -71 51 -52) (-402:403:-532:533:534)
      (-538:547:-539:540:-406:407) (-541:544:-545:546:-408)
      (-548:655)
      imp:n=1 $ NW Tank Quadrant
4102 1 9.9961E-02 (40:-39:42:-41) (3 -13 -71 51 52) (-402:403:-532:533:534)

```

Fundamental - FUND

NRAD-FUND-RESR-001
CRIT-REAC-COEF

```
(-402:403:-432:433:434) (-438:447:-439:440:-406:407)
(-441:444:-445:446:-408) (-448:605)
(-538:547:-539:540:-406:407) (-541:544:-545:546:-408)
(-548:655) imp:n=1 $ NE Tank Quadrant
4103 1 9.9961E-02 (40:-39:42:-41) (3 -13 -71 -51 -52) imp:n=1 $ SW Tank Quadrant
4104 1 9.9961E-02 (40:-39:42:-41) (3 -13 -71 -51 52) (-402:403:-432:433:434)
(-438:447:-439:440:-406:407) (-441:444:-445:446:-408)
(-448:605) imp:n=1 $ SE Tank Quadrant
```

```
c
c --- Model Boundary -----
9999 0 -1:13:72 imp:n=0
c
```

c Surface Cards *****

c --- Primary Model Dimensions -----

c ----- Horizontal Planes -----

```
1 pz 0 $ Tank Bottom Surface
2 pz 1.27 $ Tank/Mounting Pad Interface
3 pz 3.81 $ Mounting Pad Top Surface/Bottom of Support Structure
5 pz 45.95876 $ Bottom of Grid Plate Structure
6 pz 51.03876 $ Top of Support Structure and Grid Plate Bolt Plates
7 pz 58.65876 $ Top of Grid Plate Structure
9 pz 62.46876 $ Top of Lower Adapter Assembly
10 pz 128.19127 $ Bottom of Upper Handle Assembly
12 pz 140.89127 $ Top of Upper Handle Assembly
13 pz 203.2 $ Tank Water Top Boundary
```

c ----- Vertical Planes -----

```
31 px -4.05003 $ West Assembly Boundary
32 px 4.05003 $ East Assembly Boundary
33 py -3.85445 $ South Assembly Boundary
34 py 3.85445 $ North Assembly Boundary
35 px -24.31415 $ West Side of Grid Plate
36 px 24.31415 $ East Side of Grid Plate
37 py -23.33625 $ South Side of Grid Plate
38 py 23.33625 $ North Side of Grid Plate
39 px -27.49042 $ West Side of Support Structure
40 px 27.49042 $ East Side of Support Structure
41 py -26.51125 $ South Side of Support Structure
42 py 26.51125 $ North Side of Support Structure
```

```
51 py 0 $ N/S Division of Tank
52 px 0 $ E/W Division of Tank
c
```

c ----- Radii -----

```
71 cz 99.06 $ Inner Tank Surface
72 cz 99.695 $ Outer Tank Surface
c
```

c --- Fuel Rods -----

c ----- Horizontal Planes -----

```
102 pz 67.54876 $ Bottom of Clad Tube
103 pz 68.81876 $ Bottom End Fitting/Bottom Graphite Reflector Interface
104 pz 77.50556 $ Bottom Graphite Reflector/Moly Disc Interface
105 pz 77.584935 $ Moly Disc/Fuel Rods Interface
106 pz 115.604935 $ Fuel Rods/Top Graphite Reflector Interface
107 pz 124.291735 $ Top Graphite Reflector/Air Gap Interface
108 pz 125.01627 $ Air Gap/Top End Fitting Interface
109 pz 126.28627 $ Top of Clad Tube
c
```

c ----- Vertical Planes -----

```
131 px -1.9431 $ West Fuel Boundary
132 px 1.9431 $ East Fuel Boundary
133 py -1.9431 $ South Fuel Boundary
134 py 1.9431 $ North Fuel Boundary
c
```

c ----- Radii -----

```
151 cz 1.27 $ Bottom End Fitting
152 cz 1.63957 $ Axial Graphite Reflectors
153 cz 1.73482 $ Moly Poison Disc
154 cz 0.28575 $ Zirconium Rods
155 cz 1.74025 $ Fuel Rod OD
156 cz 1.7447 $ Cladding Inner Surface
157 cz 1.7955 $ Cladding Outer Surface
158 cz 1.6764 $ Top End Fitting
159 cz 0.3175 $ Fuel Rod ID
c
```

Fundamental - FUND

NRAD-FUND-RESR-001
CRIT-REAC-COEF

```

c --- Control Rods -----
c ----- Horizontal Planes -----
201 pz 71.35876 $ Bottom End Fitting/Guide Tube Interface
202 pz 73.89876 $ Inside Bottom of Guide Tube
203 pz 163.91636 $ Top of Guide Tube
c
231 pz 76.12126 $ Bottom of Control Rod Clad
232 pz 77.70876 $ Clad/B4C Rod Interface
233 pz 115.80876 $ B4C Rod/Spacer Interface
234 pz 117.07876 $ Spacer/Void Interface
235 pz 133.58876 $ Void/Clad Interface
236 pz 135.55726 $ Top of Control Rod Clad
237 pz 137.14476 $ Top End Fitting/Attachment Region Interface
238 pz 145.08226 $ Attachment Region/Extension Rod Interface
239 pz 230.80726 $ Top of Extension Rod
c
c ----- Radii -----
251 cz 1.27 $ Bottom End Fitting
252 cz 1.7399 $ Guide Tube Inner Surface
253 cz 1.8796 $ Guide Tube Outer Surface
c
261 c/z -1.9431 1.9431 1.88 $ NW Control Rod Cut Out
262 c/z 1.9431 1.9431 1.88 $ NE Control Rod Cut Out
263 c/z -1.9431 -1.9431 1.88 $ SW Control Rod Cut Out
264 c/z 1.9431 -1.9431 1.88 $ SE Control Rod Cut Out
c
271 cz 1.50749 $ B4C/Spacer Outer Surface
272 cz 0.635 $ Spacer Hole
273 cz 1.33985 $ Void Tube Inner Surface
274 cz 1.42875 $ Void Tube Outer Surface
275 cz 1.51638 $ Cladding Inner Surface
276 cz 1.5875 $ Cladding Outer Surface
277 cz 0.88773 $ Top End Fitting
278 cz 1.42875 $ Rod Attachment Region
279 cz 0.80645 $ Extension Rod Inner Surface
280 cz 1.11125 $ Extension Rod Outer Surface
c
c --- Graphite Reflector Assemblies -----
c ----- Horizontal Planes -----
302 pz 64.37376 $ Top of Dowel Pins
303 pz 64.69126 $ Top of Dowel Pin Holes
304 pz 65.32626 $ Top of Tie Rod
305 pz 65.64376 $ Top of Tie Rod Hole
306 pz 124.38126 $ Bottom of Screw Holes
307 pz 125.01626 $ Bottom of Screws
309 pz 141.04366 $ Top of Upper Handle Assembly
c
311 pz 95.16999 $ Inside Bottom of AmBe Source
312 pz 98.35515 $ Inside Top of AmBe Source
313 pz 98.5139 $ Outside Top of AmBe Source
c
321 pz 91.99626 $ Bottom of Water Hole in Graphite
322 pz 93.26626 $ Bottom of Source Hole/Source Tube
323 pz 95.01124 $ Inside Bottom of Source Tube
324 pz 131.52628 $ Bottom of Source Tube Cap
325 pz 135.81126 $ Inside Top of Source Tube Cap
326 pz 136.76376 $ Top of Source Tube Cap
327 pz 139.30376 $ Tip of Source Tube Cap
c
c ----- Vertical Planes -----
331 px -3.683 $ West Graphite Surface
332 px 3.683 $ East Graphite Surface
333 py -3.683 $ South Graphite Surface
334 py 3.683 $ North Graphite Surface
335 p -3.683 2.7305 1 -3.683 2.7305 -1 -2.7305 3.683 1 $ NW Chamfer
336 p 3.683 2.7305 1 3.683 2.7305 -1 2.7305 3.683 1 $ NE Chamfer
337 p -3.683 -2.7305 1 -3.683 -2.7305 -1 -2.7305 -3.683 1 $ SW Chamfer
338 p 3.683 -2.7305 1 3.683 -2.7305 -1 2.7305 -3.683 1 $ SE Chamfer
c
341 py -1.82372 $ Cutoff Surface for Water Hole in Graphite
342 px 1.18872 $ West Source Tube Cap Tip
343 px 2.45872 $ East Source Tube Cap Tip
344 py -2.45872 $ South Source Tube Cap Tip
345 py -1.18872 $ North Source Tube Cap Tip
c
c ----- Radii -----

```

Fundamental - FUND

NRAD-FUND-RESR-001
CRIT-REAC-COEF

```

351 cz 0.79375 $ Tie Rod/Tie Rod Hole
352 c/z 1.9431 1.9431 0.81915 $ Dowel NE
353 c/z -1.9431 -1.9431 0.81915 $ Dowel SW
354 c/z 1.9431 1.9431 0.83312 $ Dowel Hole NE
355 c/z -1.9431 -1.9431 0.83312 $ Dowel Hole SW
356 c/z 1.9431 1.9431 0.79375 $ Screw/Screw Hole NE
357 c/z -1.9431 -1.9431 0.79375 $ Screw/Screw Hole SW
c
361 c/z 1.82372 -1.82372 0.889 $ Inside Surface of AmBe Source
362 c/z 1.82372 -1.82372 1.04775 $ Outside Surface of AmBe Source
c
371 c/z 1.82372 -1.82372 1.34874 $ Source Hole
372 c/z 1.82372 -1.82372 0.3175 $ Water Holes in Graphite and Source Tube
373 c/z 1.82372 -1.82372 1.34874 $ Source Tube Outer Surface
374 c/z 1.82372 -1.82372 1.22936 $ Source Tube Inner Surface
375 c/z 1.82372 -1.82372 1.82499 $ Source Tube Cap Outer Surface
376 c/y 1.82372 92.31376 0.3175 $ Water Interconnect Hole in Graphite
377 c/y 1.82372 94.13875 0.23749 $ Water Interconnect Hole in Source Tube
c
c --- Beam Lines -----
c ----- Horizontal Planes -----
401 pz 84.455 $ Top of Beam Tube Support
402 pz 88.33993 $ Bottom Surface of Beam Filter Tubes
403 pz 104.84993 $ Top Surface of Beam Filter Tubes
404 pz 88.97493 $ Inside Bottom Surface of Beam Filter Tubes
405 pz 104.21493 $ Inside Top Surface of Beam Filter Tubes
406 pz 83.25993 $ Bottom Surface of Tube Attachment Fixtures
407 pz 109.92993 $ Top Surface of Tube Attachment Fixtures
408 pz 80.71993 $ Outside Bottom Surface of Aperture Housing
409 pz 81.98993 $ Inside Bottom Surface of Aperture Housing
410 pz 90.08618 $ Bottom of Absorber Assembly
411 pz 91.51493 $ Bottom of Absorber Block
412 pz 108.65993 $ Top of Absorber Block
413 pz 111.67618 $ Top of Absorber Assembly
c
c ----- Vertical Planes -----
c ----- East Beam Assembly -----
431 px 17.92069 $ Core Face of Beam Filter Tube
432 py -6.985 $ South Surface of Beam Filter Tube
433 py 6.985 $ North Surface of Beam Filter Tube
434 px 51.57569 $ Back End of Beam Filter Tube
435 px 18.14929 $ Inside Core Face of Beam Filter Tube
436 py -6.6675 $ Inside South Surface of Beam Filter Tube
437 py 6.6675 $ Inside North Surface of Beam Filter Tube
438 px 47.76569 $ Beam Filter Tube Attachment Fixtures
439 py -10.4775 $ South Surface of Tube Attachment Fixtures
440 py 10.4775 $ North Surface of Tube Attachment Fixtures
441 px 52.84569 $ Core-Side Face of Beam Aperture Housing
442 px 52.52819 $ Beam Window Surface on Filter Tube
443 px 53.16319 $ Beam Window Surface on Aperture Housing
444 px 64.27569 $ Tank-Side Face of Beam Aperture Housing
445 py -7.9375 $ South Surface of Aperture Housing
446 py 7.9375 $ North Surface of Aperture Housing
447 px 54.11569 $ Inside Core-Side Face of Aperture Housing
448 px 63.00569 $ Inside Tank-Side Face of Aperture Housing
449 py -6.6675 $ Inside South Surface of Aperture Housing
450 py 6.6675 $ Inside North Surface of Aperture Housing
451 px 64.19949 $ Beam Window Surface on Aperture Housing
452 px 69.35569 $ Disc Absorber/Stop Interface
453 px 69.51317 $ Beam Window Surface in Absorber Stop
454 px 69.99069 $ Tank-Side Face of Absorber Stop
455 py -6.62686 $ South Surface of Absorber Assembly
456 py 6.62686 $ North Surface of Absorber Assembly
457 py -5.08 $ South Surface of Absorber Block
458 py 5.08 $ North Surface of Absorber Block
459 px 57.29069 $ Core-Side Face of Absorber Assembly
460 px 57.60819 $ Core-Side Face of Absorber Block
461 px 62.68819 $ Tank-Side Face of Absorber Block
c
c ----- North Beam Assembly -----
531 py 17.33395 $ Core Face of West Beam Filter Tube
532 px -6.985 $ East Surface of West Beam Filter Tube
533 px 6.985 $ West Surface of West Beam Filter Tube
534 py 52.57645 $ Back End of Beam Filter Tube
535 py 17.56255 $ Inside Core Face of Beam Filter Tube
536 px -6.6675 $ Inside East Surface of Beam Filter Tube

```

Fundamental - FUND

NRAD-FUND-RESR-001
CRIT-REAC-COEF

537 px 6.6675 \$ Inside West Surface of Beam Filter Tube
 538 py 48.76645 \$ Beam Filter Tube Attachment Fixtures
 539 px -10.4775 \$ East Surface of Tube Attachment Fixtures
 540 px 10.4775 \$ West Surface of Tube Attachment Fixtures
 541 py 53.84645 \$ Core-Side Face of Beam Aperture Housing
 542 py 53.52895 \$ Beam Window Surface on Filter Tube
 543 py 54.16395 \$ Beam Window Surface on Aperture Housing
 544 py 65.27645 \$ Tank-Side Face of Beam Aperture Housing
 545 px -7.9375 \$ East Surface of Aperture Housing
 546 px 7.9375 \$ West Surface of Aperture Housing
 547 py 55.11645 \$ Inside Core-Side Face of Aperture Housing
 548 py 64.00645 \$ Inside Tank-Side Face of Aperture Housing
 549 px -6.6675 \$ Inside East Surface of Aperture Housing
 550 px 6.6675 \$ Inside West Surface of Aperture Housing
 551 py 65.20025 \$ Beam Window Surface on Aperture Housing
 552 py 70.35645 \$ Disc Absorber/Stop Interface
 553 py 70.51393 \$ Beam Window Surface in Absorber Stop
 554 py 70.99145 \$ Tank-Side Face of Absorber Stop
 555 px -6.62686 \$ East Surface of Absorber Assembly
 556 px 6.62686 \$ West Surface of Absorber Assembly
 557 px -5.08 \$ East Surface of Absorber Block
 558 px 5.08 \$ West Surface of Absorber Block
 559 py 58.29145 \$ Core-Side Face of Absorber Assembly
 560 py 58.60895 \$ Core-Side Face of Absorber Block
 561 py 63.68895 \$ Tank-Side Face of Absorber Block

c

c ----- Radii -----

c ----- East Beam Assembly -----

601 c/x 0 96.59493 5.3975 \$ Beam Filter Window
 602 c/x 0 96.59493 4.52374 \$ Beam Tube Window
 603 c/x 0 96.59493 5.715 \$ Beam Tube Window
 604 c/x 0 96.59493 10.16 \$ Beam Tube Inner Surface
 605 c/x 0 96.59493 11.43 \$ Beam Tube Outer Surface
 606 c/x 0 96.59493 10.11936 \$ Beam Tube Absorber Stop

c

631 c/x 0 96.59793 4.445 \$ Disc Absorber Inner Hole
 632 c/x 0 96.59793 10.1346 \$ Disc Absorber Outer Surface
 633 c/x 0 96.59793 1.77165 \$ Bottom Hole in Block Absorber
 634 c/x 0 103.57993 0.7366 \$ Top Hole in Block Absorber

c

c ----- North Beam Assembly -----

651 c/y 0 96.59493 5.3975 \$ Beam Filter Window
 652 c/y 0 96.59493 4.52374 \$ Beam Tube Window
 653 c/y 0 96.59493 5.715 \$ Beam Tube Window
 654 c/y 0 96.59493 10.16 \$ Beam Tube Inner Surface
 655 c/y 0 96.59493 11.43 \$ Beam Tube Outer Surface
 656 c/y 0 96.59493 10.11936 \$ Beam Tube Absorber Stop

c

671 c/y 0 96.59793 4.445 \$ Disc Absorber Inner Hole
 672 c/y 0 96.59793 10.1346 \$ Disc Absorber Outer Surface
 673 c/y 0 96.59793 1.77165 \$ Bottom Hole in Block Absorber
 674 c/y 0 103.57993 0.7366 \$ Top Hole in Block Absorber

c

c Data Cards *****

c

c *** Material Cards *****

c --- Water -----

m1 1001.70c 6.6633E-02 1002.70c 7.6637E-06 8016.70c 3.3308E-02
 8017.70c 1.2662E-05
 c Total 9.9961E-02

mt1 lwtr.10t hwtr.10t

c

c --- Air -----

m2 1001.70c 5.0303E-07 1002.70c 5.7856E-11 7014.70c 3.9123E-05
 7015.70c 1.4451E-07 8016.70c 1.0800E-05 8017.70c 4.1056E-09
 18036.70c 7.9027E-10 18038.70c 1.4843E-10 18040.70c 2.3391E-07
 6000.70c 9.5977E-09 2003.70c 1.8051E-16 2004.70c 1.3176E-10
 36078.70c 1.0033E-13 36080.70c 6.5356E-13 36082.70c 3.3194E-12
 36083.70c 3.2936E-12 36084.70c 1.6339E-11 36086.70c 4.9590E-12
 c Total 5.0820E-05

mt2 lwtr.10t hwtr.10t

c

c --- Fuel Rods (Non-Fuel Components) -----

c ----- Axial Graphite Reflectors -----

m11 3006.70c 2.8481E-10 3007.70c 3.4676E-09 4009.70c 2.8900E-09

Fundamental - FUND

NRAD-FUND-RESR-001
CRIT-REAC-COEF

5010.70c	6.7120E-09	5011.70c	2.7016E-08	6000.70c	8.6734E-02
9019.70c	2.7419E-09	11023.70c	1.1329E-09	12024.70c	8.4647E-10
12025.70c	1.0716E-10	12026.70c	1.1798E-10	13027.70c	9.6531E-10
14028.70c	2.5659E-08	14029.70c	1.3029E-09	14030.70c	8.5889E-10
15031.70c	1.6818E-09	16032.70c	2.8372E-08	16033.70c	2.2714E-10
16034.70c	1.2822E-09	16036.70c	5.9774E-12	17035.70c	5.3445E-09
17037.70c	1.7082E-09	19039.70c	1.2425E-09	19040.70c	1.5588E-13
19041.70c	8.9667E-11	20040.70c	6.2999E-10	20042.70c	4.2047E-12
20043.70c	8.7733E-13	20044.70c	1.3556E-11	20046.70c	2.5995E-14
20048.70c	1.2153E-12	21045.70c	1.1587E-10	22046.70c	8.9756E-12
22047.70c	8.0944E-12	22048.70c	8.0204E-11	22049.70c	5.8858E-12
22050.70c	5.6356E-12	23000.70c	1.0226E-10	24050.70c	2.1765E-10
24052.70c	4.1971E-09	24053.70c	4.7592E-10	24054.70c	1.1847E-10
25055.70c	9.4818E-11	26054.70c	5.4519E-12	26056.70c	8.5583E-11
26057.70c	1.9765E-12	26058.70c	2.6303E-13	27059.70c	8.8390E-11
28058.70c	6.0423E-11	28060.70c	2.3275E-11	28061.70c	1.0117E-12
28062.70c	3.2259E-12	28064.70c	8.2153E-13	29063.70c	2.8351E-10
29065.70c	1.2636E-10	30000.70c	3.9831E-10	31069.70c	4.4908E-11
31071.70c	2.9804E-11	32070.70c	7.4754E-11	32072.70c	9.8787E-11
32073.70c	2.7728E-11	32074.70c	1.3014E-10	32076.70c	2.7297E-11
33075.70c	3.4764E-10	34074.70c	2.9357E-12	34076.70c	3.0908E-11
34077.70c	2.5168E-11	34078.70c	7.8407E-11	34080.70c	1.6364E-10
34082.70c	2.8797E-11	35079.70c	3.3046E-10	35081.70c	3.2146E-10
37085.70c	2.1993E-10	37087.70c	8.4810E-11	38084.70c	1.6646E-12
38086.70c	2.9309E-11	38087.70c	2.0808E-11	38088.70c	2.4547E-10
39089.70c	2.9296E-10	40090.70c	1.4690E-10	40091.70c	3.2034E-11
40092.70c	4.8965E-11	40094.70c	4.9622E-11	40096.70c	7.9943E-12
41093.70c	2.8034E-10	42092.70c	4.0287E-11	42094.70c	2.5112E-11
42095.70c	4.3219E-11	42096.70c	4.5283E-11	42097.70c	2.5926E-11
42098.70c	6.5508E-11	42100.70c	2.6143E-11	44096.70c	1.4276E-11
44098.70c	4.8190E-12	44099.70c	3.2882E-11	44100.70c	3.2470E-11
44101.70c	4.3963E-11	44102.70c	8.1304E-11	44104.70c	4.7983E-11
45103.70c	5.0620E-11	46102.70c	2.4964E-12	46104.70c	2.7264E-11
46105.70c	5.4651E-11	46106.70c	6.6888E-11	46108.70c	6.4759E-11
46110.70c	2.8684E-11	47107.70c	1.2517E-10	47109.70c	1.1629E-10
48106.70c	2.8963E-12	48108.70c	2.0621E-12	48110.70c	2.8940E-11
48111.70c	2.9658E-11	48112.70c	5.5910E-11	48113.70c	2.8314E-11
48114.70c	6.6568E-11	48116.70c	1.7354E-11	49113.70c	9.7314E-12
49115.70c	2.1711E-10	50112.70c	2.1282E-12	50114.70c	1.4481E-12
50115.70c	7.4598E-13	50116.70c	3.1902E-11	50117.70c	1.6850E-11
50118.70c	5.3140E-11	50119.70c	1.8847E-11	50120.70c	7.1482E-11
50122.70c	1.0158E-11	50124.70c	1.2704E-11	51121.70c	1.2239E-10
51123.70c	9.1539E-11	52120.70c	1.8371E-13	52122.70c	5.2050E-12
52123.70c	1.8167E-12	52124.70c	9.6752E-12	52125.70c	1.4431E-11
52126.70c	3.8456E-11	52128.70c	6.4787E-11	52130.70c	6.9564E-11
53127.70c	4.1048E-11	55133.70c	1.9597E-10	56130.70c	2.0104E-13
56132.70c	1.9156E-13	56134.70c	4.5841E-12	56135.70c	1.2502E-11
56136.70c	1.4896E-11	56137.70c	2.1303E-11	56138.70c	1.3598E-10
57138.70c	1.6876E-13	57139.70c	1.8734E-10	58136.70c	3.4389E-13
58138.70c	4.6658E-13	58140.70c	1.6442E-10	58142.70c	2.0660E-11
59141.70c	1.8484E-10	60142.70c	4.9115E-11	60143.70c	2.2030E-11
60144.70c	4.2976E-11	60145.70c	1.4987E-11	60146.70c	3.1058E-11
60148.70c	1.0293E-11	60150.70c	1.0112E-11	62144.70c	1.0636E-12
62147.70c	5.1932E-12	62148.70c	3.8940E-12	62149.70c	4.7878E-12
62150.70c	2.5567E-12	62152.70c	9.2673E-12	62154.70c	7.8816E-12
63151.70c	1.6389E-11	63153.70c	1.7890E-11	64152.70c	6.6253E-14
64154.70c	7.2215E-13	64155.70c	4.9027E-12	64156.70c	6.7810E-12
64157.70c	5.1843E-12	64158.70c	8.2286E-12	64160.70c	7.2414E-12
65159.70c	3.2777E-11	66156.70c	1.9234E-14	66158.70c	3.2056E-14
66160.70c	7.5011E-13	66161.70c	6.0618E-12	66162.70c	8.1775E-12
66163.70c	7.9820E-12	66164.70c	9.0334E-12	67165.70c	3.1584E-11
68162.70c	4.3601E-14	68164.70c	5.0142E-13	68166.70c	1.0467E-11
68167.70c	7.1413E-12	68168.70c	8.3403E-12	68170.70c	4.6498E-12
69169.55c	3.0835E-11	5010.70c	4.0640E-15	71175.70c	2.9001E-11
71176.70c	7.7109E-13	72174.70c	4.6695E-14	72176.70c	1.5351E-12
72177.70c	5.4283E-12	72178.70c	7.9615E-12	72179.70c	3.9749E-12
72180.70c	1.0238E-11	73181.70c	2.8788E-07	74182.70c	3.7542E-11
74183.70c	2.0273E-11	74184.70c	4.3407E-11	74186.70c	4.0446E-11
75185.70c	1.0463E-11	75187.70c	1.7512E-11	76000.31c	2.7388E-11
77191.70c	1.0108E-11	77193.70c	1.6992E-11	78000.31c	2.6702E-11
79197.70c	2.6447E-10	80196.70c	3.8953E-13	80198.70c	2.5891E-11
80199.70c	4.3810E-11	80200.70c	5.9988E-11	80201.70c	3.4227E-11
80202.70c	7.7543E-11	80204.70c	1.7841E-11	81000.31c	1.2743E-10
82204.70c	1.7598E-12	82206.70c	3.0294E-11	82207.70c	2.7780E-11
82208.70c	6.5868E-11	83209.70c	1.2463E-10	90232.70c	1.1225E-10
92234.70c	6.0182E-15	92235.70c	7.8784E-13	92238.70c	1.0863E-10

Fundamental - FUND

NRAD-FUND-RESR-001
CRIT-REAC-COEF

```

c      Total      8.6735E-02
mt11  grp10t
c
c ----- Moly Poison Disc -----
m12   3006.70c 3.3650E-10   3007.70c 4.0970E-09   4009.70c 3.4146E-09
      5010.70c 5.6644E-10   5011.70c 2.2800E-09   6000.70c 5.1241E-05
      9019.70c 1.6198E-09   11023.70c 7.7234E-07   12024.70c 7.4008E-08
      12025.70c 9.3693E-09   12026.70c 1.0316E-08   13027.70c 1.0037E-07
      14028.70c 4.0422E-07   14029.70c 2.0525E-08   14030.70c 1.3530E-08
      15031.70c 1.0134E-07   16032.70c 3.5434E-07   16033.70c 2.8368E-09
      16034.70c 1.6013E-08   16036.70c 7.4653E-11   17035.70c 1.3155E-09
      17037.70c 4.2046E-10   19039.70c 3.6700E-06   19040.70c 4.6043E-10
      19041.70c 2.6486E-07   20040.70c 2.6796E-07   20042.70c 1.7884E-09
      20043.70c 3.7316E-10   20044.70c 5.7661E-09   20046.70c 1.1057E-11
      20048.70c 5.1690E-10   21045.70c 3.4226E-10   22046.70c 5.3024E-08
      22047.70c 4.7818E-08   22048.70c 4.7381E-07   22049.70c 3.4771E-08
      22050.70c 3.3292E-08   23000.70c 1.3290E-07   24050.70c 1.9543E-08
      24052.70c 3.7688E-07   24053.70c 4.2735E-08   24054.70c 1.0638E-08
      25055.70c 4.8172E-08   26054.70c 7.5687E-08   26056.70c 1.1881E-06
      26057.70c 2.7439E-08   26058.70c 3.6516E-09   27059.70c 1.4621E-08
      28058.70c 8.5667E-08   28060.70c 3.2999E-08   28061.70c 1.4344E-09
      28062.70c 4.5736E-09   28064.70c 1.1648E-09   29063.70c 1.6748E-07
      29065.70c 7.4649E-08   30000.70c 2.3530E-09   31069.70c 1.3265E-09
      31071.70c 8.8034E-10   32070.70c 8.8322E-10   32072.70c 1.1672E-09
      32073.70c 3.2761E-10   32074.70c 1.5376E-09   32076.70c 3.2252E-10
      33075.70c 2.8751E-08   34074.70c 3.4686E-11   34076.70c 3.6518E-10
      34077.70c 2.9736E-10   34078.70c 9.2638E-10   34080.70c 1.9334E-09
      34082.70c 3.4023E-10   35079.70c 1.9522E-10   35081.70c 1.8990E-10
      37085.70c 1.2993E-09   37087.70c 5.0101E-10   38084.70c 9.8339E-11
      38086.70c 1.7315E-09   38087.70c 1.2292E-09   38088.70c 1.4501E-08
      39089.70c 3.4613E-09   40090.70c 1.7356E-09   40091.70c 3.7849E-10
      40092.70c 5.7853E-10   40094.70c 5.8629E-10   40096.70c 9.4453E-11
      41093.70c 1.6561E-08   42092.70c 9.5169E-03   42094.70c 5.9320E-03
      42095.70c 1.0210E-02   42096.70c 1.0697E-02   42097.70c 6.1244E-03
      42098.70c 1.5475E-02   42100.70c 6.1757E-03   44096.70c 8.4339E-11
      44098.70c 2.8468E-11   44099.70c 1.9425E-10   44100.70c 1.9182E-10
      44101.70c 2.5971E-10   44102.70c 4.8030E-10   44104.70c 2.8346E-10
      45103.70c 1.4952E-09   46102.70c 2.9495E-11   46104.70c 3.2213E-10
      46105.70c 6.4571E-10   46106.70c 7.9029E-10   46108.70c 7.6513E-10
      46110.70c 3.3890E-10   47107.70c 7.3944E-09   47109.70c 6.8697E-09
      48106.70c 3.4220E-09   48108.70c 2.4364E-09   48110.70c 3.4192E-08
      48111.70c 3.5041E-08   48112.70c 6.6057E-08   48113.70c 3.3453E-08
      48114.70c 7.8650E-08   48116.70c 2.0504E-08   49113.70c 5.7488E-11
      49115.70c 1.2826E-09   50112.70c 9.5551E-11   50114.70c 6.5014E-11
      50115.70c 3.3492E-11   50116.70c 1.4323E-09   50117.70c 7.5653E-10
      50118.70c 2.3858E-09   50119.70c 8.4617E-10   50120.70c 3.2093E-09
      50122.70c 4.5609E-10   50124.70c 5.7035E-10   51121.70c 3.7596E-08
      51123.70c 2.8120E-08   52120.70c 1.0853E-12   52122.70c 3.0749E-11
      52123.70c 1.0732E-11   52124.70c 5.7157E-11   52125.70c 8.5253E-11
      52126.70c 2.2718E-10   52128.70c 3.8273E-10   52130.70c 4.1095E-10
      53127.70c 2.4249E-10   55133.70c 1.1577E-09   56130.70c 7.1259E-10
      56132.70c 6.7898E-10   56134.70c 1.6248E-08   56135.70c 4.4315E-08
      56136.70c 5.2799E-08   56137.70c 7.5508E-08   56138.70c 4.8199E-07
      57138.70c 3.7684E-11   57139.70c 4.1833E-08   58136.70c 2.0315E-12
      58138.70c 2.7563E-12   58140.70c 9.7130E-10   58142.70c 1.2205E-10
      59141.70c 2.1839E-10   60142.70c 5.8030E-11   60143.70c 2.6028E-11
      60144.70c 5.0776E-11   60145.70c 1.7708E-11   60146.70c 3.6695E-11
      60148.70c 1.2161E-11   60150.70c 1.1947E-11   62144.70c 6.2831E-12
      62147.70c 3.0679E-11   62148.70c 2.3004E-11   62149.70c 2.8284E-11
      62150.70c 1.5104E-11   62152.70c 5.4747E-11   62154.70c 4.6561E-11
      63151.70c 9.6818E-11   63153.70c 1.0569E-10   64152.70c 3.9139E-13
      64154.70c 4.2661E-12   64155.70c 2.8963E-11   64156.70c 4.0059E-11
      64157.70c 3.0626E-11   64158.70c 4.8610E-11   64160.70c 4.2779E-11
      65159.70c 1.9363E-10   66156.70c 1.1362E-13   66158.70c 1.8937E-13
      66160.70c 4.4313E-12   66161.70c 3.5810E-11   66162.70c 4.8309E-11
      66163.70c 4.7154E-11   66164.70c 5.3365E-11   67165.70c 1.8658E-10
      68162.70c 2.5758E-13   68164.70c 2.9621E-12   68166.70c 6.1837E-11
      68167.70c 4.2187E-11   68168.70c 4.9271E-11   68170.70c 2.7469E-11
      69169.55c 1.8216E-10   5010.70c 2.4008E-14   71175.70c 1.7132E-10
      71176.70c 4.5553E-12   72174.70c 2.7585E-13   72176.70c 9.0686E-12
      72177.70c 3.2068E-11   72178.70c 4.7033E-11   72179.70c 2.3482E-11
      72180.70c 6.0480E-11   73181.70c 1.7007E-07   74182.70c 1.1089E-06
      74183.70c 5.9880E-07   74184.70c 1.2821E-06   74186.70c 1.1947E-06
      75185.70c 1.6070E-09   75187.70c 2.6898E-09   76000.31c 8.0896E-10
      77191.70c 2.9857E-10   77193.70c 5.0189E-10   78000.31c 7.8873E-10
      79197.70c 7.8117E-10   80196.70c 1.1506E-12   80198.70c 7.6476E-11

```

Fundamental - FUND

NRAD-FUND-RESR-001
CRIT-REAC-COEF

	80199.70c	1.2940E-10	80200.70c	1.7719E-10	80201.70c	1.0110E-10
	80202.70c	2.2904E-10	80204.70c	5.2697E-11	81000.31c	7.5282E-10
	82204.70c	1.0396E-11	82206.70c	1.7896E-10	82207.70c	1.6411E-10
	82208.70c	3.8912E-10	83209.70c	7.3626E-10	90232.70c	6.6310E-11
	92234.70c	5.6884E-14	92235.70c	7.4467E-12	92238.70c	1.0268E-09
c	Total	6.4196E-02				
c						
c	----- Zr Rod -----					
m13	3006.70c	1.0717E-10	3007.70c	1.3049E-09	4009.70c	1.0875E-09
	5010.70c	3.6082E-09	5011.70c	1.4523E-08	9019.70c	1.0318E-07
	11023.70c	8.5264E-10	12024.70c	3.1853E-10	12025.70c	4.0325E-11
	12026.70c	4.4398E-11	13027.70c	5.8120E-06	14028.70c	9.1406E-07
	14029.70c	4.6414E-08	14030.70c	3.0596E-08	15031.70c	9.9991E-08
	16032.70c	2.9012E-08	16033.70c	2.3226E-10	16034.70c	1.3111E-09
	16036.70c	6.1122E-12	17035.70c	1.9273E-08	17037.70c	6.1600E-09
	19039.70c	4.6755E-09	19040.70c	5.8658E-13	19041.70c	3.3742E-10
	20040.70c	2.3707E-09	20042.70c	1.5822E-11	20043.70c	3.3014E-12
	20044.70c	5.1013E-11	20046.70c	9.7819E-14	20048.70c	4.5730E-12
	21045.70c	3.1801E-07	22046.70c	1.1484E-08	22047.70c	1.0356E-08
	22048.70c	1.0261E-07	22049.70c	7.5305E-09	22050.70c	7.2103E-09
	23000.70c	3.3092E-08	24050.70c	3.9312E-07	24052.70c	7.5810E-06
	24053.70c	8.5963E-07	24054.70c	2.1398E-07	25055.70c	9.9904E-07
	26054.70c	6.1547E-06	26056.70c	9.6615E-05	26057.70c	2.2313E-06
	26058.70c	2.9694E-07	27059.70c	7.3175E-08	28058.70c	2.8649E-06
	28060.70c	1.1035E-06	28061.70c	4.7970E-08	28062.70c	1.5295E-07
	28064.70c	3.8952E-08	29063.70c	5.5476E-07	29065.70c	2.4726E-07
	30000.70c	2.4581E-08	31069.70c	7.4355E-08	31071.70c	4.9347E-08
	32070.70c	2.8130E-10	32072.70c	3.7174E-10	32073.70c	1.0434E-10
	32074.70c	4.8971E-10	32076.70c	1.0272E-10	33075.70c	2.0931E-09
	34074.70c	1.1047E-11	34076.70c	1.1631E-10	34077.70c	9.4708E-11
	34078.70c	2.9505E-10	34080.70c	6.1579E-10	34082.70c	1.0836E-10
	35079.70c	6.2176E-10	35081.70c	6.0483E-10	37085.70c	8.2761E-10
	37087.70c	3.1914E-10	38084.70c	6.2640E-12	38086.70c	1.1029E-10
	38087.70c	7.8300E-11	38088.70c	9.2372E-10	39089.70c	1.1024E-09
	40090.70c	2.2070E-02	40091.70c	4.8130E-03	40092.70c	7.3568E-03
	40094.70c	7.4555E-03	40096.70c	1.2011E-03	41093.70c	2.5740E-08
	42092.70c	1.3341E-08	42094.70c	8.3156E-09	42095.70c	1.4312E-08
	42096.70c	1.4995E-08	42097.70c	8.5853E-09	42098.70c	2.1692E-08
	42100.70c	8.6572E-09	44096.70c	5.3723E-11	44098.70c	1.8134E-11
	44099.70c	1.2374E-10	44100.70c	1.2218E-10	44101.70c	1.6543E-10
	44102.70c	3.0595E-10	44104.70c	1.8056E-10	45103.70c	9.5242E-10
	46102.70c	9.3939E-11	46104.70c	1.0260E-09	46105.70c	2.0565E-09
	46106.70c	2.5170E-09	46108.70c	2.4369E-09	46110.70c	1.0794E-09
	47107.70c	4.7101E-09	47109.70c	4.3759E-09	48106.70c	1.0899E-10
	48108.70c	7.7599E-11	48110.70c	1.0890E-09	48111.70c	1.1160E-09
	48112.70c	2.1039E-09	48113.70c	1.0655E-09	48114.70c	2.5050E-09
	48116.70c	6.5305E-10	49113.70c	7.3238E-11	49115.70c	1.6339E-09
	50112.70c	1.5697E-10	50114.70c	1.0680E-10	50115.70c	5.5020E-11
	50116.70c	2.3529E-09	50117.70c	1.2428E-09	50118.70c	3.9193E-09
	50119.70c	1.3901E-09	50120.70c	5.2722E-09	50122.70c	7.4924E-10
	50124.70c	9.3695E-10	51121.70c	4.6054E-10	51123.70c	3.4446E-10
	52120.70c	6.9129E-13	52122.70c	1.9587E-11	52123.70c	6.8361E-12
	52124.70c	3.6408E-11	52125.70c	5.4305E-11	52126.70c	1.4471E-10
	52128.70c	2.4380E-10	52130.70c	2.6177E-10	53127.70c	1.5446E-09
	55133.70c	7.3744E-11	56130.70c	7.5652E-14	56132.70c	7.2083E-14
	56134.70c	1.7250E-12	56135.70c	4.7047E-12	56136.70c	5.6054E-12
	56137.70c	8.0162E-12	56138.70c	5.1171E-11	57138.70c	6.3503E-14
	57139.70c	7.0495E-11	58136.70c	1.2941E-13	58138.70c	1.7557E-13
	58140.70c	6.1870E-11	58142.70c	7.7742E-12	59141.70c	6.9556E-11
	60142.70c	1.8482E-11	60143.70c	8.2898E-12	60144.70c	1.6172E-11
	60145.70c	5.6398E-12	60146.70c	1.1687E-11	60148.70c	3.8731E-12
	60150.70c	3.8051E-12	62144.70c	2.0011E-12	62147.70c	9.7710E-12
	62148.70c	7.3266E-12	62149.70c	9.0083E-12	62150.70c	4.8105E-12
	62152.70c	1.7437E-11	62154.70c	1.4829E-11	63151.70c	3.0836E-11
	63153.70c	3.3661E-11	64152.70c	1.2465E-13	64154.70c	1.3587E-12
	64155.70c	9.2244E-12	64156.70c	1.2758E-11	64157.70c	9.7542E-12
	64158.70c	1.5482E-11	64160.70c	1.3625E-11	65159.70c	6.1670E-11
	66156.70c	3.6188E-14	66158.70c	6.0314E-14	66160.70c	1.4113E-12
	66161.70c	1.1405E-11	66162.70c	1.5386E-11	66163.70c	1.5018E-11
	66164.70c	1.6996E-11	67165.70c	5.9425E-11	68162.70c	8.2036E-14
	68164.70c	9.4341E-13	68166.70c	1.9695E-11	68167.70c	1.3436E-11
	68168.70c	1.5692E-11	68170.70c	8.7486E-12	69169.55c	5.8016E-11
	5010.70c	7.6464E-15	71175.70c	5.4565E-11	71176.70c	1.4508E-12
	72174.70c	1.9328E-09	72176.70c	6.3542E-08	72177.70c	2.2469E-07
	72178.70c	3.2955E-07	72179.70c	1.6453E-07	72180.70c	4.2378E-07
	73181.70c	5.4165E-08	74182.70c	6.7810E-10	74183.70c	3.6617E-10

Fundamental - FUND

NRAD-FUND-RESR-001
CRIT-REAC-COEF

74184.70c	7.8403E-10	74186.70c	7.3055E-10	75185.70c	1.9685E-11	
75187.70c	3.2949E-11	76000.31c	5.1530E-11	77191.70c	1.9019E-11	
77193.70c	3.1970E-11	78000.31c	5.0241E-11	79197.70c	4.9760E-10	
80196.70c	7.3291E-13	80198.70c	4.8714E-11	80199.70c	8.2428E-11	
80200.70c	1.1287E-10	80201.70c	6.4398E-11	80202.70c	1.4590E-10	
80204.70c	3.3567E-11	81000.31c	9.5908E-11	82204.70c	9.5361E-11	
82206.70c	1.6416E-09	82207.70c	1.5053E-09	82208.70c	3.5692E-09	
83209.70c	3.0015E-09	90232.70c	8.4477E-12	92234.70c	6.3410E-14	
92235.70c	8.3010E-12	92238.70c	1.1446E-09			
c	Total	4.3026E-02				
c						
c	----- SS 304 Cladding and End Fittings -----					
m14	3006.70c	2.6341E-10	3007.70c	3.2070E-09	4009.70c	2.6729E-09
	5010.70c	2.2170E-07	5011.70c	8.9237E-07	6000.70c	1.6044E-04
	9019.70c	1.2679E-09	11023.70c	1.0478E-09	12024.70c	2.8183E-07
	12025.70c	3.5679E-08	12026.70c	3.9283E-08	13027.70c	2.1427E-06
	14028.70c	6.3283E-04	14029.70c	3.2134E-05	14030.70c	2.1183E-05
	15031.70c	4.0441E-05	16032.70c	3.1374E-06	16033.70c	2.5117E-08
	16034.70c	1.4178E-07	16036.70c	6.6099E-10	17035.70c	2.5744E-09
	17037.70c	8.2281E-10	19039.70c	5.7456E-10	19040.70c	7.2084E-14
	19041.70c	4.1465E-11	20040.70c	5.8265E-08	20042.70c	3.8887E-10
	20043.70c	8.1140E-11	20044.70c	1.2538E-09	20046.70c	2.4042E-12
	20048.70c	1.1239E-10	21045.70c	2.6791E-10	22046.70c	1.6602E-07
	22047.70c	1.4972E-07	22048.70c	1.4835E-06	22049.70c	1.0887E-07
	22050.70c	1.0424E-07	23000.70c	9.4573E-05	24050.70c	7.6491E-04
	24052.70c	1.4751E-02	24053.70c	1.6726E-03	24054.70c	4.1634E-04
	25055.70c	8.7693E-04	26054.70c	3.4644E-03	26056.70c	5.4383E-02
	26057.70c	1.2559E-03	26058.70c	1.6714E-04	27059.70c	6.5399E-05
	28058.70c	5.5882E-03	28060.70c	2.1526E-03	28061.70c	9.3571E-05
	28062.70c	2.9834E-04	28064.70c	7.5980E-05	29063.70c	1.5732E-04
	29065.70c	7.0120E-05	30000.70c	3.6838E-08	31069.70c	6.6453E-07
	31071.70c	4.4103E-07	32070.70c	2.7655E-07	32072.70c	3.6546E-07
	32073.70c	1.0258E-07	32074.70c	4.8144E-07	32076.70c	1.0098E-07
	33075.70c	2.2506E-06	34074.70c	2.7151E-11	34076.70c	2.8585E-10
	34077.70c	2.3277E-10	34078.70c	7.2515E-10	34080.70c	1.5135E-09
	34082.70c	2.6633E-10	35079.70c	1.5281E-09	35081.70c	1.4865E-09
	37085.70c	1.0170E-08	37087.70c	3.9218E-09	38084.70c	3.0791E-11
	38086.70c	5.4214E-10	38087.70c	3.8489E-10	38088.70c	4.5406E-09
	39089.70c	1.3547E-09	40090.70c	4.8909E-08	40091.70c	1.0666E-08
	40092.70c	1.6303E-08	40094.70c	1.6522E-08	40096.70c	2.6617E-09
	41093.70c	5.7041E-06	42092.70c	2.2356E-05	42094.70c	1.3935E-05
	42095.70c	2.3983E-05	42096.70c	2.5128E-05	42097.70c	1.4387E-05
	42098.70c	3.6351E-05	42100.70c	1.4507E-05	44096.70c	1.3204E-10
	44098.70c	4.4568E-11	44099.70c	3.0411E-10	44100.70c	3.0030E-10
	44101.70c	4.0660E-10	44102.70c	7.5194E-10	44104.70c	4.4378E-10
	45103.70c	1.1704E-09	46102.70c	1.1544E-11	46104.70c	1.2608E-10
	46105.70c	2.5272E-10	46106.70c	3.0931E-10	46108.70c	2.9946E-10
	46110.70c	1.3264E-10	47107.70c	5.7882E-09	47109.70c	5.3775E-09
	48106.70c	2.6786E-11	48108.70c	1.9072E-11	48110.70c	2.6765E-10
	48111.70c	2.7429E-10	48112.70c	5.1708E-10	48113.70c	2.6186E-10
	48114.70c	6.1566E-10	48116.70c	1.6050E-10	49113.70c	4.5001E-10
	49115.70c	1.0040E-08	50112.70c	2.1651E-08	50114.70c	1.4732E-08
	50115.70c	7.5891E-09	50116.70c	3.2455E-07	50117.70c	1.7143E-07
	50118.70c	5.4061E-07	50119.70c	1.9174E-07	50120.70c	7.2722E-07
	50122.70c	1.0335E-07	50124.70c	1.2924E-07	51121.70c	2.0148E-07
	51123.70c	1.5070E-07	52120.70c	8.4951E-13	52122.70c	2.4070E-11
	52123.70c	8.4007E-12	52124.70c	4.4741E-11	52125.70c	6.6734E-11
	52126.70c	1.7783E-10	52128.70c	2.9959E-10	52130.70c	3.2168E-10
	53127.70c	9.4908E-10	55133.70c	1.8124E-10	56130.70c	9.2967E-13
	56132.70c	8.8582E-13	56134.70c	2.1198E-11	56135.70c	5.7815E-11
	56136.70c	6.8883E-11	56137.70c	9.8510E-11	56138.70c	6.2882E-10
	57138.70c	1.5607E-13	57139.70c	1.7326E-10	58136.70c	1.5902E-12
	58138.70c	2.1576E-12	58140.70c	7.6031E-10	58142.70c	9.5535E-11
	59141.70c	8.5476E-11	60142.70c	2.2712E-11	60143.70c	1.0187E-11
	60144.70c	1.9873E-11	60145.70c	6.9306E-12	60146.70c	1.4362E-11
	60148.70c	4.7596E-12	60150.70c	4.6761E-12	62144.70c	2.4591E-12
	62147.70c	1.2007E-11	62148.70c	9.0035E-12	62149.70c	1.1070E-11
	62150.70c	5.9116E-12	62152.70c	2.1427E-11	62154.70c	1.8223E-11
	63151.70c	3.7894E-11	63153.70c	4.1365E-11	64152.70c	1.5319E-13
	64154.70c	1.6697E-12	64155.70c	1.1336E-11	64156.70c	1.5679E-11
	64157.70c	1.1987E-11	64158.70c	1.9026E-11	64160.70c	1.6743E-11
	65159.70c	7.5785E-11	66156.70c	4.4471E-14	66158.70c	7.4118E-14
	66160.70c	1.7344E-12	66161.70c	1.4016E-11	66162.70c	1.8908E-11
	66163.70c	1.8455E-11	66164.70c	2.0886E-11	67165.70c	7.3026E-11
	68162.70c	1.0081E-13	68164.70c	1.1593E-12	68166.70c	2.4202E-11
	68167.70c	1.6512E-11	68168.70c	1.9284E-11	68170.70c	1.0751E-11

Fundamental - FUND

NRAD-FUND-RESR-001
CRIT-REAC-COEF

69169.55c	7.1295E-11	5010.70c	9.3965E-15	71175.70c	6.7054E-11	
71176.70c	1.7829E-12	72174.70c	2.1593E-13	72176.70c	7.0987E-12	
72177.70c	2.5102E-11	72178.70c	3.6816E-11	72179.70c	1.8381E-11	
72180.70c	4.7343E-11	73181.70c	1.3312E-08	74182.70c	1.1111E-06	
74183.70c	5.9998E-07	74184.70c	1.2846E-06	74186.70c	1.1970E-06	
75185.70c	2.4191E-09	75187.70c	4.0491E-09	76000.31c	2.2797E-09	
77191.70c	8.4138E-10	77193.70c	1.4143E-09	78000.31c	1.2348E-09	
79197.70c	6.1148E-10	80196.70c	1.8013E-12	80198.70c	1.1973E-10	
80199.70c	2.0259E-10	80200.70c	2.7740E-10	80201.70c	1.5828E-10	
80202.70c	3.5858E-10	80204.70c	8.2500E-11	81000.31c	5.8929E-10	
82204.70c	1.0091E-10	82206.70c	1.7371E-09	82207.70c	1.5930E-09	
82208.70c	3.7769E-09	83209.70c	1.1527E-10	90232.70c	5.1906E-11	
92234.70c	2.7830E-15	92235.70c	3.6432E-13	92238.70c	5.0233E-11	
c	Total	8.7412E-02				
mt14	fe56.12t					
c						
c	--- Control Rods -----					
c	----- B4C Absorber -----					
m21	5010.70c	2.1515E-02	5011.70c	8.6601E-02	6000.70c	2.7029E-02
c	Total	1.3514E-01				
mt21	grph.10t					
c						
c	----- Al 6061 Cladding and End Fittings -----					
m22	13027.70c	5.8593E-02	24050.70c	2.6495E-06	24052.70c	5.1093E-05
	24053.70c	5.7936E-06	24054.70c	1.4421E-06	29063.70c	4.8671E-05
	29065.70c	2.1694E-05	12024.70c	5.2843E-04	12025.70c	6.6898E-05
	12026.70c	7.3655E-05	25055.70c	2.2197E-05	14028.70c	3.2037E-04
	14029.70c	1.6268E-05	14030.70c	1.0724E-05	26054.70c	5.9561E-06
	26056.70c	9.3499E-05	26057.70c	2.1593E-06	26058.70c	2.8736E-07
	30000.70c	3.1082E-05	22046.70c	2.1012E-06	22047.70c	1.8949E-06
	22048.70c	1.8776E-05	22049.70c	1.3779E-06	22050.70c	1.3193E-06
	27059.70c	6.8975E-06	28058.70c	4.7151E-06	28060.70c	1.8162E-06
	28061.70c	7.8950E-08	28062.70c	2.5173E-07	28064.70c	6.4108E-08
	50112.70c	3.3215E-08	50114.70c	2.2600E-08	50115.70c	1.1642E-08
	50116.70c	4.9788E-07	50117.70c	2.6298E-07	50118.70c	8.2935E-07
	50119.70c	2.9414E-07	50120.70c	1.1156E-06	50122.70c	1.5854E-07
	50124.70c	1.9826E-07				
c	Total	5.9939E-02				
mt22	al27.12t					
c						
c	----- Homogenized Guide Tube Adapter Fitting -----					
c	28.09% SS 304 + 71.91% Al 6061					
m23	13027.70c	4.2136E-02	6000.70c	4.5065E-05	27059.70c	4.9601E-06
	24050.70c	2.1675E-04	24052.70c	4.1798E-03	24053.70c	4.7396E-04
	24054.70c	1.1798E-04	29063.70c	3.5001E-05	29065.70c	1.5600E-05
	26054.70c	9.8748E-04	26056.70c	1.5501E-02	26057.70c	3.5799E-04
	26058.70c	4.7642E-05	12024.70c	3.8001E-04	12025.70c	4.8108E-05
	12026.70c	5.2967E-05	25055.70c	2.6227E-04	28058.70c	1.5730E-03
	28060.70c	6.0592E-04	28061.70c	2.6339E-05	28062.70c	8.3979E-05
	28064.70c	2.1387E-05	15031.70c	9.8298E-06	16032.70c	6.0083E-06
	16033.70c	4.8102E-08	16034.70c	2.7152E-07	16036.70c	1.2658E-09
	14028.70c	4.5257E-04	14029.70c	2.2980E-05	14030.70c	1.5149E-05
	50112.70c	2.3886E-08	50114.70c	1.6252E-08	50115.70c	8.3723E-09
	50116.70c	3.5804E-07	50117.70c	1.8912E-07	50118.70c	5.9641E-07
	50119.70c	2.1152E-07	50120.70c	8.0227E-07	50122.70c	1.1401E-07
	50124.70c	1.4258E-07	22046.70c	1.5110E-06	22047.70c	1.3627E-06
	22048.70c	1.3502E-05	22049.70c	9.9088E-07	22050.70c	9.4875E-07
	30000.70c	2.2352E-05				
c	Total	6.7723E-02				
mt23	al27.12t	fe56.12t				
c						
c	----- Homogenized Control Rod/Extension Rod Interface -----					
c	21.91% Water + 78.09% Al 6061					
m24	1001.70c	1.4602E-02	1002.70c	1.6794E-06	8016.70c	7.2989E-03
	8017.70c	2.7746E-06	13027.70c	4.5753E-02	27059.70c	5.3860E-06
	24050.70c	2.0689E-06	24052.70c	3.9897E-05	24053.70c	4.5240E-06
	24054.70c	1.1261E-06	29063.70c	3.8006E-05	29065.70c	1.6940E-05
	26054.70c	4.6509E-06	26056.70c	7.3010E-05	26057.70c	1.6861E-06
	26058.70c	2.2439E-07	12024.70c	4.1263E-04	12025.70c	5.2239E-05
	12026.70c	5.7515E-05	25055.70c	1.7333E-05	28058.70c	3.6818E-06
	28060.70c	1.4182E-06	28061.70c	6.1650E-08	28062.70c	1.9657E-07
	28064.70c	5.0059E-08	14028.70c	2.5017E-04	14029.70c	1.2703E-05
	14030.70c	8.3738E-06	50112.70c	2.5937E-08	50114.70c	1.7648E-08
	50115.70c	9.0912E-09	50116.70c	3.8878E-07	50117.70c	2.0535E-07
	50118.70c	6.4761E-07	50119.70c	2.2969E-07	50120.70c	8.7115E-07
	50122.70c	1.2380E-07	50124.70c	1.5482E-07	22046.70c	1.6408E-06

Fundamental - FUND

NRAD-FUND-RESR-001
CRIT-REAC-COEF

```

22047.70c 1.4797E-06 22048.70c 1.4662E-05 22049.70c 1.0759E-06
22050.70c 1.0302E-06 30000.70c 2.4271E-05
c Total 6.8709E-02
mt24 lwtr.10t hwtr.10t al27.12t
c
c ----- Homogenized Guide Tube -----
c 3.53% Water + 96.47% Al 6061
m25 1001.70c 2.3519E-03 1002.70c 2.7050E-07 8016.70c 1.1756E-03
8017.70c 4.4691E-07 13027.70c 5.6525E-02 27059.70c 6.6540E-06
24050.70c 2.5560E-06 24052.70c 4.9290E-05 24053.70c 5.5891E-06
24054.70c 1.3912E-06 29063.70c 4.6954E-05 29065.70c 2.0928E-05
26054.70c 5.7459E-06 26056.70c 9.0198E-05 26057.70c 2.0831E-06
26058.70c 2.7722E-07 12024.70c 5.0978E-04 12025.70c 6.4537E-05
12026.70c 7.1055E-05 25055.70c 2.1414E-05 28058.70c 4.5486E-06
28060.70c 1.7521E-06 28061.70c 7.6164E-08 28062.70c 2.4284E-07
28064.70c 6.1845E-08 14028.70c 3.0906E-04 14029.70c 1.5693E-05
14030.70c 1.0345E-05 50112.70c 3.2043E-08 50114.70c 2.1802E-08
50115.70c 1.1231E-08 50116.70c 4.8031E-07 50117.70c 2.5370E-07
50118.70c 8.0008E-07 50119.70c 2.8376E-07 50120.70c 1.0762E-06
50122.70c 1.5295E-07 50124.70c 1.9127E-07 22046.70c 2.0271E-06
22047.70c 1.8280E-06 22048.70c 1.8113E-05 22049.70c 1.3293E-06
22050.70c 1.2727E-06 30000.70c 2.9985E-05
c Total 6.1351E-02
mt25 lwtr.10t hwtr.10t al27.12t
c
c --- Fuel Cluster Assemblies -----
c ----- Homogenized 4-Fuel-Rod Top Fittings -----
c 77.63% Water + 7.44% SS 304 + 14.93% Al 6061
m31 1001.70c 5.1728E-02 1002.70c 5.9494E-06 8016.70c 2.5857E-02
8017.70c 9.8294E-06 13027.70c 8.7492E-03 6000.70c 1.1932E-05
27059.70c 1.0299E-06 24050.70c 5.7281E-05 24052.70c 1.1046E-03
24053.70c 1.2525E-04 24054.70c 3.1178E-05 29063.70c 7.2677E-06
29065.70c 3.2393E-06 26054.70c 2.6121E-04 26056.70c 4.1005E-03
26057.70c 9.4698E-05 26058.70c 1.2603E-05 12024.70c 7.8906E-05
12025.70c 9.9894E-06 12026.70c 1.0998E-05 25055.70c 6.8531E-05
28058.70c 4.1629E-04 28060.70c 1.6036E-04 28061.70c 6.9706E-06
28062.70c 2.2225E-05 28064.70c 5.6601E-06 15031.70c 2.6027E-06
16032.70c 1.5908E-06 16033.70c 1.2736E-08 16034.70c 7.1892E-08
16036.70c 3.3516E-10 14028.70c 1.0667E-04 14029.70c 5.4163E-06
14030.70c 3.5705E-06 50112.70c 4.9597E-09 50114.70c 3.3747E-09
50115.70c 1.7385E-09 50116.70c 7.4345E-08 50117.70c 3.9269E-08
50118.70c 1.2384E-07 50119.70c 4.3922E-08 50120.70c 1.6659E-07
50122.70c 2.3674E-08 50124.70c 2.9605E-08 22046.70c 3.1376E-07
22047.70c 2.8295E-07 22048.70c 2.8037E-06 22049.70c 2.0575E-07
22050.70c 1.9700E-07 30000.70c 4.6412E-06
c Total 9.3070E-02
mt31 lwtr.10t hwtr.10t fe56.12t al27.12t
c
c ----- Homogenized 3-Fuel-Rod Top Fittings -----
c 74.79% Water + 7.10% SS 304 + 18.11% Al 6061
m32 1001.70c 4.9835E-02 1002.70c 5.7317E-06 8016.70c 2.4911E-02
8017.70c 9.4697E-06 13027.70c 1.0611E-02 6000.70c 1.1391E-05
27059.70c 1.2491E-06 24050.70c 5.4789E-05 24052.70c 1.0565E-03
24053.70c 1.1980E-04 24054.70c 2.9822E-05 29063.70c 8.8144E-06
29065.70c 3.9287E-06 26054.70c 2.4961E-04 26056.70c 3.9184E-03
26057.70c 9.0492E-05 26058.70c 1.2043E-05 12024.70c 9.5699E-05
12025.70c 1.2115E-05 12026.70c 1.3339E-05 25055.70c 6.6282E-05
28058.70c 3.9762E-04 28060.70c 1.5316E-04 28061.70c 6.6578E-06
28062.70c 2.1228E-05 28064.70c 5.4062E-06 15031.70c 2.4848E-06
16032.70c 1.5188E-06 16033.70c 1.2159E-08 16034.70c 6.8635E-08
16036.70c 3.1998E-10 14028.70c 1.1418E-04 14029.70c 5.7979E-06
14030.70c 3.8220E-06 50112.70c 6.0153E-09 50114.70c 4.0929E-09
50115.70c 2.1085E-09 50116.70c 9.0167E-08 50117.70c 4.7626E-08
50118.70c 1.5020E-07 50119.70c 5.3269E-08 50120.70c 2.0204E-07
50122.70c 2.8712E-08 50124.70c 3.5906E-08 22046.70c 3.8053E-07
22047.70c 3.4317E-07 22048.70c 3.4004E-06 22049.70c 2.4954E-07
22050.70c 2.3893E-07 30000.70c 5.6290E-06
c Total 9.1839E-02
mt32 lwtr.10t hwtr.10t fe56.12t al27.12t
c
c ----- Homogenized 3- & 4-Fuel-Rod Bottom Fittings -----
c 34.78% Water + 13.86% SS 304 + 51.36% Al 6061
m33 1001.70c 2.3172E-02 1002.70c 2.6651E-06 8016.70c 1.1583E-02
8017.70c 4.4032E-06 13027.70c 3.0094E-02 6000.70c 2.2242E-05
27059.70c 3.5427E-06 24050.70c 1.0740E-04 24052.70c 2.0711E-03
24053.70c 2.3484E-04 24054.70c 5.8457E-05 29063.70c 2.4999E-05

```

Fundamental - FUND

NRAD-FUND-RESR-001
CRIT-REAC-COEF

29065.70c	1.1142E-05	26054.70c	4.8832E-04	26056.70c	7.6655E-03	
26057.70c	1.7703E-04	26058.70c	2.3559E-05	12024.70c	2.7141E-04	
12025.70c	3.4360E-05	12026.70c	3.7831E-05	25055.70c	1.3297E-04	
28058.70c	7.7710E-04	28060.70c	2.9934E-04	28061.70c	1.3012E-05	
28062.70c	4.1488E-05	28064.70c	1.0566E-05	15031.70c	4.8515E-06	
16032.70c	2.9654E-06	16033.70c	2.3741E-08	16034.70c	1.3401E-07	
16036.70c	6.2475E-10	14028.70c	2.7421E-04	14029.70c	1.3924E-05	
14030.70c	9.1785E-06	50112.70c	1.7060E-08	50114.70c	1.1608E-08	
50115.70c	5.9798E-09	50116.70c	2.5572E-07	50117.70c	1.3507E-07	
50118.70c	4.2597E-07	50119.70c	1.5108E-07	50120.70c	5.7300E-07	
50122.70c	8.1430E-08	50124.70c	1.0183E-07	22046.70c	1.0792E-06	
22047.70c	9.7327E-07	22048.70c	9.6437E-06	22049.70c	7.0771E-07	
22050.70c	6.7762E-07	30000.70c	1.5964E-05			
c	Total	7.7699E-02				
mt33	lwtr.10t	hwtr.10t	fe56.12t	al27.12t		
c						
c	--- Graphite Reflector Assemblies -----					
c	----- Graphite Reflectors -----					
m41	3006.70c	2.5847E-10	3007.70c	3.1469E-09	4009.70c	2.6227E-09
	5010.70c	1.3053E-08	5011.70c	5.2538E-08	6000.70c	7.8692E-02
	9019.70c	2.4883E-09	11023.70c	6.1688E-09	12024.70c	4.3018E-08
	12025.70c	5.4460E-09	12026.70c	5.9961E-09	13027.70c	4.5554E-08
	14028.70c	2.5149E-06	14029.70c	1.2770E-07	14030.70c	8.4181E-08
	15031.70c	5.4945E-08	16032.70c	1.3993E-06	16033.70c	1.1203E-08
	16034.70c	6.3238E-08	16036.70c	2.9481E-10	17035.70c	4.6481E-08
	17037.70c	1.4856E-08	19039.70c	1.1276E-09	19040.70c	1.4146E-13
	19041.70c	8.1374E-11	20040.70c	5.2599E-07	20042.70c	3.5105E-09
	20043.70c	7.3249E-10	20044.70c	1.1318E-08	20046.70c	2.1703E-11
	20048.70c	1.0146E-09	21045.70c	1.4722E-09	22046.70c	2.9324E-08
	22047.70c	2.6445E-08	22048.70c	2.6203E-07	22049.70c	1.9229E-08
	22050.70c	1.8412E-08	23000.70c	5.3824E-07	24050.70c	1.9752E-10
	24052.70c	3.8089E-09	24053.70c	4.3190E-10	24054.70c	1.0751E-10
	25055.70c	2.0652E-09	26054.70c	5.4425E-08	26056.70c	8.5435E-07
	26057.70c	1.9731E-08	26058.70c	2.6258E-09	27059.70c	8.0215E-11
	28058.70c	3.8384E-08	28060.70c	1.4785E-08	28061.70c	6.4271E-10
	28062.70c	2.0493E-09	28064.70c	5.2189E-10	29063.70c	2.5729E-10
	29065.70c	1.1468E-10	30000.70c	3.6147E-10	31069.70c	4.0754E-11
	31071.70c	2.7048E-11	32070.70c	6.7840E-11	32072.70c	8.9651E-11
	32073.70c	2.5163E-11	32074.70c	1.1810E-10	32076.70c	2.4773E-11
	33075.70c	3.1549E-10	34074.70c	2.6642E-12	34076.70c	2.8049E-11
	34077.70c	2.2840E-11	34078.70c	7.1156E-11	34080.70c	1.4851E-10
	34082.70c	2.6133E-11	35079.70c	2.9990E-10	35081.70c	2.9173E-10
	37085.70c	1.9959E-10	37087.70c	7.6966E-11	38084.70c	3.0818E-11
	38086.70c	5.4261E-10	38087.70c	3.8522E-10	38088.70c	4.5445E-09
	39089.70c	2.6586E-10	40090.70c	2.3463E-09	40091.70c	5.1166E-10
	40092.70c	7.8209E-10	40094.70c	7.9258E-10	40096.70c	1.2769E-10
	41093.70c	2.5441E-10	42092.70c	3.6561E-11	42094.70c	2.2789E-11
	42095.70c	3.9222E-11	42096.70c	4.1095E-11	42097.70c	2.3528E-11
	42098.70c	5.9449E-11	42100.70c	2.3725E-11	44096.70c	1.2956E-11
	44098.70c	4.3733E-12	44099.70c	2.9841E-11	44100.70c	2.9467E-11
	44101.70c	3.9897E-11	44102.70c	7.3784E-11	44104.70c	4.3546E-11
	45103.70c	4.5939E-11	46102.70c	2.2655E-12	46104.70c	2.4743E-11
	46105.70c	4.9597E-11	46106.70c	6.0702E-11	46108.70c	5.8770E-11
	46110.70c	2.6031E-11	47107.70c	1.1359E-10	47109.70c	1.0553E-10
	48106.70c	2.6284E-12	48108.70c	1.8714E-12	48110.70c	2.6263E-11
	48111.70c	2.6915E-11	48112.70c	5.0739E-11	48113.70c	2.5695E-11
	48114.70c	6.0411E-11	48116.70c	1.5749E-11	49113.70c	8.8314E-12
	49115.70c	1.9703E-10	50112.70c	1.9314E-12	50114.70c	1.3141E-12
	50115.70c	6.7699E-13	50116.70c	2.8951E-11	50117.70c	1.5292E-11
	50118.70c	4.8225E-11	50119.70c	1.7104E-11	50120.70c	6.4871E-11
	50122.70c	9.2189E-12	50124.70c	1.1529E-11	51121.70c	1.1107E-10
	51123.70c	8.3073E-11	52120.70c	1.6672E-13	52122.70c	4.7236E-12
	52123.70c	1.6486E-12	52124.70c	8.7804E-12	52125.70c	1.3097E-11
	52126.70c	3.4899E-11	52128.70c	5.8795E-11	52130.70c	6.3130E-11
	53127.70c	3.7251E-11	55133.70c	1.7785E-10	56130.70c	1.8245E-13
	56132.70c	1.7384E-13	56134.70c	4.1601E-12	56135.70c	1.1346E-11
	56136.70c	1.3518E-11	56137.70c	1.9333E-11	56138.70c	1.2341E-10
	57138.70c	1.5315E-13	57139.70c	1.7001E-10	58136.70c	3.1209E-13
	58138.70c	4.2343E-13	58140.70c	1.4921E-10	58142.70c	1.8749E-11
	59141.70c	1.6775E-10	60142.70c	4.4573E-11	60143.70c	1.9992E-11
	60144.70c	3.9001E-11	60145.70c	1.3601E-11	60146.70c	2.8186E-11
	60148.70c	9.3406E-12	60150.70c	9.1768E-12	62144.70c	9.6521E-13
	62147.70c	4.7129E-12	62148.70c	3.5339E-12	62149.70c	4.3450E-12
	62150.70c	2.3203E-12	62152.70c	8.4103E-12	62154.70c	7.1526E-12
	63151.70c	1.4873E-11	63153.70c	1.6236E-11	64152.70c	6.0125E-14
	64154.70c	6.5537E-13	64155.70c	4.4493E-12	64156.70c	6.1538E-12

Fundamental - FUND

NRAD-FUND-RESR-001
CRIT-REAC-COEF

64157.70c	4.7048E-12	64158.70c	7.4676E-12	64160.70c	6.5717E-12	
65159.70c	2.9746E-11	66156.70c	1.7455E-14	66158.70c	2.9091E-14	
66160.70c	6.8074E-13	66161.70c	5.5012E-12	66162.70c	7.4212E-12	
66163.70c	7.2438E-12	66164.70c	8.1979E-12	67165.70c	2.8663E-11	
68162.70c	3.9569E-14	68164.70c	4.5504E-13	68166.70c	9.4994E-12	
68167.70c	6.4808E-12	68168.70c	7.5690E-12	68170.70c	4.2197E-12	
69169.55c	2.7983E-11	5010.70c	3.6881E-15	71175.70c	2.6319E-11	
71176.70c	6.9978E-13	72174.70c	4.2376E-14	72176.70c	1.3931E-12	
72177.70c	4.9263E-12	72178.70c	7.2252E-12	72179.70c	3.6073E-12	
72180.70c	9.2910E-12	73181.70c	2.6125E-07	74182.70c	3.4070E-11	
74183.70c	1.8398E-11	74184.70c	3.9392E-11	74186.70c	3.6705E-11	
75185.70c	9.4950E-12	75187.70c	1.5893E-11	76000.31c	2.4855E-11	
77191.70c	9.1733E-12	77193.70c	1.5420E-11	78000.31c	2.4233E-11	
79197.70c	2.4001E-10	80196.70c	3.5351E-13	80198.70c	2.3497E-11	
80199.70c	3.9758E-11	80200.70c	5.4440E-11	80201.70c	3.1062E-11	
80202.70c	7.0372E-11	80204.70c	1.6191E-11	81000.31c	1.1565E-10	
82204.70c	1.5971E-12	82206.70c	2.7493E-11	82207.70c	2.5211E-11	
82208.70c	5.9776E-11	83209.70c	1.1311E-10	90232.70c	1.0187E-10	
92234.70c	5.4616E-15	92235.70c	7.1497E-13	92238.70c	9.8582E-11	
c	Total	7.8699E-02				
mt41	grph.10t					
c						
c	----- Al 2011 Fittings -----					
m42	13027.70c	5.8488E-02	83209.70c	3.2505E-05	29063.70c	1.0167E-03
	29065.70c	4.5315E-04	26054.70c	6.2209E-06	26056.70c	9.7654E-05
	26057.70c	2.2553E-06	26058.70c	3.0013E-07	82204.70c	4.5898E-07
	82206.70c	7.9010E-06	82207.70c	7.2454E-06	82208.70c	1.7179E-05
	14028.70c	1.1154E-04	14029.70c	5.6635E-06	14030.70c	3.7334E-06
	30000.70c	3.8956E-05	27059.70c	7.2041E-06	28058.70c	4.9246E-06
	28060.70c	1.8970E-06	28061.70c	8.2459E-08	28062.70c	2.6292E-07
	28064.70c	6.6957E-08	50112.70c	3.4691E-08	50114.70c	2.3604E-08
	50115.70c	1.2160E-08	50116.70c	5.2001E-07	50117.70c	2.7467E-07
	50118.70c	8.6621E-07	50119.70c	3.0722E-07	50120.70c	1.1652E-06
	50122.70c	1.6559E-07	50124.70c	2.0708E-07		
c	Total	6.0307E-02				
mt42	al27.12t					
c						
c	----- Homogenized Reflector Top Fittings -----					
c	79.64% Water + 2.61% Al 2011 + 17.76% Al 6061					
m43	1001.70c	5.3064E-02	1002.70c	6.1030E-06	8016.70c	2.6525E-02
	8017.70c	1.0083E-05	13027.70c	1.1929E-02	83209.70c	8.4709E-07
	27059.70c	1.4126E-06	24050.70c	4.7051E-07	24052.70c	9.0733E-06
	24053.70c	1.0288E-06	24054.70c	2.5610E-07	29063.70c	3.5138E-05
	29065.70c	1.5662E-05	26054.70c	1.2198E-06	26056.70c	1.9149E-05
	26057.70c	4.4223E-07	26058.70c	5.8852E-08	12024.70c	9.3840E-05
	12025.70c	1.1880E-05	12026.70c	1.3080E-05	25055.70c	3.9419E-06
	28058.70c	9.6565E-07	28060.70c	3.7197E-07	28061.70c	1.6169E-08
	28062.70c	5.1554E-08	28064.70c	1.3129E-08	82204.70c	1.1961E-08
	82206.70c	2.0590E-07	82207.70c	1.8882E-07	82208.70c	4.4769E-07
	14028.70c	5.9799E-05	14029.70c	3.0364E-06	14030.70c	2.0016E-06
	50112.70c	6.8025E-09	50114.70c	4.6285E-09	50115.70c	2.3844E-09
	50116.70c	1.0197E-07	50117.70c	5.3859E-08	50118.70c	1.6985E-07
	50119.70c	6.0241E-08	50120.70c	2.2848E-07	50122.70c	3.2470E-08
	50124.70c	4.0605E-08	22046.70c	3.7314E-07	22047.70c	3.3651E-07
	22048.70c	3.3343E-06	22049.70c	2.4469E-07	22050.70c	2.3429E-07
	30000.70c	6.5349E-06				
c	Total	9.1820E-02				
mt43	lwtr.10t hwtr.10t al27.12t					
c						
c	----- Homogenized Reflector Bottom Fittings -----					
c	41.92% Water + 6.55% Al 2011 + 0.17% SS 304 + 51.36% Al 6061					
m44	1001.70c	2.7935E-02	1002.70c	3.2129E-06	8016.70c	1.3964E-02
	8017.70c	5.3082E-06	13027.70c	3.3923E-02	83209.70c	2.1277E-06
	6000.70c	2.7124E-07	27059.70c	4.0142E-06	24050.70c	2.6540E-06
	24052.70c	5.1179E-05	24053.70c	5.8033E-06	24054.70c	1.4446E-06
	29063.70c	9.1549E-05	29065.70c	4.0805E-05	26054.70c	9.3842E-06
	26056.70c	1.4731E-04	26057.70c	3.4021E-06	26058.70c	4.5275E-07
	12024.70c	2.7141E-04	12025.70c	3.4360E-05	12026.70c	3.7831E-05
	25055.70c	1.2883E-05	28058.70c	1.2191E-05	28060.70c	4.6961E-06
	28061.70c	2.0414E-07	28062.70c	6.5088E-07	28064.70c	1.6576E-07
	15031.70c	5.9165E-08	82204.70c	3.0044E-08	82206.70c	5.1719E-07
	82207.70c	4.7427E-07	82208.70c	1.1245E-06	16032.70c	3.6163E-08
	16033.70c	2.8952E-10	16034.70c	1.6343E-09	16036.70c	7.6190E-12
	14028.70c	1.7319E-04	14029.70c	8.7940E-06	14030.70c	5.7971E-06
	50112.70c	1.9331E-08	50114.70c	1.3153E-08	50115.70c	6.7757E-09
	50116.70c	2.8976E-07	50117.70c	1.5305E-07	50118.70c	4.8267E-07

Fundamental - FUND

NRAD-FUND-RESR-001
CRIT-REAC-COEF

	50119.70c	1.7119E-07	50120.70c	6.4927E-07	50122.70c	9.2269E-08
	50124.70c	1.1539E-07	22046.70c	1.0792E-06	22047.70c	9.7327E-07
	22048.70c	9.6437E-06	22049.70c	7.0771E-07	22050.70c	6.7762E-07
	30000.70c	1.8514E-05				
c	Total	7.6788E-02				
mt44	lwtr.10t	hwtr.10t	fe56.12t	al27.12t		
c	c ----- Smearred AmBe Source -----					
m45	95241.70c	4.3062E-04	4009.70c	2.7129E-03	93237.70c	2.9906E-05
	94239.70c	4.9228E-07	94240.70c	1.8486E-07	92235.70c	1.1985E-08
	92238.70c	1.0787E-07	8016.70c	9.2230E-04	8017.70c	3.5061E-07
	21045.70c	3.3943E-06	38084.70c	1.0549E-08	38086.70c	1.8573E-07
	38087.70c	1.3186E-07	38088.70c	1.5555E-06	39089.70c	1.7280E-06
	40090.70c	9.4258E-07	40091.70c	2.0555E-07	40092.70c	3.1419E-07
	40094.70c	3.1841E-07	40096.70c	5.1297E-08	42092.70c	2.9383E-07
	42094.70c	1.8315E-07	42095.70c	3.1522E-07	42096.70c	3.3026E-07
	42097.70c	1.8909E-07	42098.70c	4.7777E-07	42100.70c	1.9067E-07
	56130.70c	1.4663E-09	56132.70c	1.3971E-09	56134.70c	3.3434E-08
	56135.70c	9.1186E-08	56136.70c	1.0864E-07	56137.70c	1.5537E-07
	56138.70c	9.9178E-07	74182.70c	4.6832E-08	74183.70c	2.5289E-08
	74184.70c	5.4148E-08	74186.70c	5.0455E-08		
c	Total	4.1093E-03				
mt45	be.10t	o2/u.10t				
c	c ----- SS 304 Source Container -----					
m46	26054.70c	3.5004E-03	26056.70c	5.4949E-02	26057.70c	1.2690E-03
	26058.70c	1.6888E-04	24050.70c	7.6491E-04	24052.70c	1.4751E-02
	24053.70c	1.6726E-03	24054.70c	4.1634E-04	28058.70c	5.5882E-03
	28060.70c	2.1526E-03	28061.70c	9.3571E-05	28062.70c	2.9834E-04
	28064.70c	7.5980E-05	25055.70c	8.7693E-04	14028.70c	7.9104E-04
	14029.70c	4.0167E-05	14030.70c	2.6478E-05	6000.70c	1.6044E-04
	15031.70c	3.4997E-05	16032.70c	2.1391E-05	16033.70c	1.7126E-07
	16034.70c	9.6669E-07	16036.70c	4.5067E-09		
c	Total	8.7653E-02				
mt46	fe56.12t					
c	c ----- Homogenized Source Reflector Top Fitting -----					
c	77.53% Water + 3.13% Al 2011 + 19.34% Al 6061					
m47	1001.70c	5.1663E-02	1002.70c	5.9419E-06	8016.70c	2.5824E-02
	8017.70c	9.8170E-06	13027.70c	1.3161E-02	83209.70c	1.0176E-06
	27059.70c	1.5593E-06	24050.70c	5.1232E-07	24052.70c	9.8795E-06
	24053.70c	1.1203E-06	24054.70c	2.7886E-07	29063.70c	4.1240E-05
	29065.70c	1.8381E-05	26054.70c	1.3464E-06	26056.70c	2.1136E-05
	26057.70c	4.8813E-07	26058.70c	6.4961E-08	12024.70c	1.0218E-04
	12025.70c	1.2936E-05	12026.70c	1.4242E-05	25055.70c	4.2921E-06
	28058.70c	1.0659E-06	28060.70c	4.1058E-07	28061.70c	1.7848E-08
	28062.70c	5.6906E-08	28064.70c	1.4492E-08	82204.70c	1.4369E-08
	82206.70c	2.4735E-07	82207.70c	2.2682E-07	82208.70c	5.3781E-07
	14028.70c	6.5439E-05	14029.70c	3.3229E-06	14030.70c	2.1905E-06
	50112.70c	7.5086E-09	50114.70c	5.1090E-09	50115.70c	2.6319E-09
	50116.70c	1.1255E-07	50117.70c	5.9450E-08	50118.70c	1.8748E-07
	50119.70c	6.6494E-08	50120.70c	2.5220E-07	50122.70c	3.5840E-08
	50124.70c	4.4820E-08	22046.70c	4.0630E-07	22047.70c	3.6641E-07
	22048.70c	3.6306E-06	22049.70c	2.6643E-07	22050.70c	2.5511E-07
	30000.70c	7.2297E-06				
c	Total	9.0981E-02				
mt47	lwtr.10t	hwtr.10t	al27.12t			
c	c --- Beam Lines -----					
c	c ----- Homogenized Beam Tube Support -----					
c	79.49% Water + 20.51% Al 6061					
m51	1001.70c	5.2965E-02	1002.70c	6.0917E-06	8016.70c	2.6476E-02
	8017.70c	1.0065E-05	13027.70c	1.2019E-02	27059.70c	1.4148E-06
	24050.70c	5.4347E-07	24052.70c	1.0480E-05	24053.70c	1.1884E-06
	24054.70c	2.9581E-07	29063.70c	9.9836E-06	29065.70c	4.4498E-06
	26054.70c	1.2217E-06	26056.70c	1.9179E-05	26057.70c	4.4292E-07
	26058.70c	5.8944E-08	12024.70c	1.0839E-04	12025.70c	1.3722E-05
	12026.70c	1.5108E-05	25055.70c	4.5531E-06	28058.70c	9.6716E-07
	28060.70c	3.7255E-07	28061.70c	1.6194E-08	28062.70c	5.1635E-08
	28064.70c	1.3150E-08	14028.70c	6.5715E-05	14029.70c	3.3368E-06
	14030.70c	2.1997E-06	50112.70c	6.8131E-09	50114.70c	4.6357E-09
	50115.70c	2.3881E-09	50116.70c	1.0213E-07	50117.70c	5.3943E-08
	50118.70c	1.7012E-07	50119.70c	6.0335E-08	50120.70c	2.2884E-07
	50122.70c	3.2520E-08	50124.70c	4.0668E-08	22046.70c	4.3101E-07
	22047.70c	3.8869E-07	22048.70c	3.8514E-06	22049.70c	2.8264E-07
	22050.70c	2.7062E-07	30000.70c	6.3756E-06		

Fundamental - FUND

NRAD-FUND-RESR-001
CRIT-REAC-COEF

```

c      Total      9.1752E-02
mt51  lwtr.10t hwtr.10t al27.12t
c
c ----- Al 6061 Beam Tubes -----
m52   13027.70c 5.8593E-02 24050.70c 2.6495E-06 24052.70c 5.1093E-05
      24053.70c 5.7936E-06 24054.70c 1.4421E-06 29063.70c 4.8671E-05
      29065.70c 2.1694E-05 12024.70c 5.2843E-04 12025.70c 6.6898E-05
      12026.70c 7.3655E-05 25055.70c 2.2197E-05 14028.70c 3.2037E-04
      14029.70c 1.6268E-05 14030.70c 1.0724E-05 26054.70c 5.9561E-06
      26056.70c 9.3499E-05 26057.70c 2.1593E-06 26058.70c 2.8736E-07
      30000.70c 3.1082E-05 22046.70c 2.1012E-06 22047.70c 1.8949E-06
      22048.70c 1.8776E-05 22049.70c 1.3779E-06 22050.70c 1.3193E-06
      27059.70c 6.8975E-06 28058.70c 4.7151E-06 28060.70c 1.8162E-06
      28061.70c 7.8950E-08 28062.70c 2.5173E-07 28064.70c 6.4108E-08
      50112.70c 3.3215E-08 50114.70c 2.2600E-08 50115.70c 1.1642E-08
      50116.70c 4.9788E-07 50117.70c 2.6298E-07 50118.70c 8.2935E-07
      50119.70c 2.9414E-07 50120.70c 1.1156E-06 50122.70c 1.5854E-07
      50124.70c 1.9826E-07
c      Total      5.9939E-02
mt52  al27.12t
c
c ----- Helium -----
m53   2003.70c 1.6794E-12 2004.70c 1.2258E-06
c      Total      1.2258E-06
c
c ----- Boron Nitride -----
m54   5010.70c 9.6267E-03 5011.70c 3.8749E-02 7014.70c 4.8197E-02
      7015.70c 1.7802E-04 13027.70c 6.8105E-07 79197.70c 6.3900E-09
      4009.70c 1.3966E-07 20040.70c 1.8899E-05 20042.70c 1.2614E-07
      20043.70c 2.6319E-08 20044.70c 4.0668E-07 20046.70c 7.7983E-10
      20048.70c 3.6457E-08 24050.70c 2.3980E-08 24052.70c 4.6243E-07
      24053.70c 5.2436E-08 24054.70c 1.3052E-08 29063.70c 1.3700E-08
      29065.70c 6.1063E-09 26054.70c 1.3173E-09 26056.70c 2.0679E-08
      26057.70c 4.7756E-10 26058.70c 6.3554E-11 19039.70c 6.9048E-07
      19040.70c 8.6626E-11 19041.70c 4.9830E-08 12024.70c 4.0904E-08
      12025.70c 5.1784E-09 12026.70c 5.7015E-09 25055.70c 3.2074E-08
      42092.70c 1.9468E-09 42094.70c 1.2135E-09 42095.70c 2.0885E-09
      42096.70c 2.1882E-09 42097.70c 1.2528E-09 42098.70c 3.1656E-09
      42100.70c 1.2633E-09 11023.70c 1.0949E-06 28058.70c 1.4599E-08
      28060.70c 5.6236E-09 28061.70c 2.4445E-10 28062.70c 7.7943E-10
      28064.70c 1.9850E-10 82204.70c 8.5042E-11 82206.70c 1.4639E-09
      82207.70c 1.3424E-09 82208.70c 3.1830E-09 14028.70c 9.9634E-05
      14029.70c 5.0592E-06 14030.70c 3.3350E-06 50112.70c 1.0284E-10
      50114.70c 6.9976E-11 50115.70c 3.6048E-11 50116.70c 1.5416E-09
      50117.70c 8.1427E-10 50118.70c 2.5679E-09 50119.70c 9.1075E-10
      50120.70c 3.4543E-09 50122.70c 4.9089E-10 50124.70c 6.1388E-10
      22046.70c 2.1687E-09 22047.70c 1.9557E-09 22048.70c 1.9379E-08
      22049.70c 1.4221E-09 22050.70c 1.3617E-09 23000.70c 2.4707E-08
      74182.70c 1.8142E-09 74183.70c 9.7965E-10 74184.70c 2.0976E-09
      74186.70c 1.9545E-09 30000.70c 1.9248E-08 40090.70c 7.0986E-09
      40091.70c 1.5480E-09 40092.70c 2.3662E-09 40094.70c 2.3979E-09
      40096.70c 3.8632E-10 8016.70c 3.3814E-03 8017.70c 1.2854E-06
c      Total      1.0026E-01
c
c --- Structural Materials -----
c ----- Homogenized Empty Grid Plate -----
c      51.85% Water + 48.15% Al 1100
m61   1001.70c 3.4550E-02 1002.70c 3.9738E-06 8016.70c 1.7271E-02
      8017.70c 6.5653E-06 13027.70c 2.8897E-02 27059.70c 3.3333E-06
      29063.70c 1.0691E-05 29065.70c 4.7653E-06 26054.70c 2.0560E-06
      26056.70c 3.2275E-05 26057.70c 7.4537E-07 26058.70c 9.9194E-08
      25055.70c 3.5757E-06 28058.70c 2.2786E-06 28060.70c 8.7772E-07
      28061.70c 3.8154E-08 28062.70c 1.2165E-07 28064.70c 3.0981E-08
      14028.70c 6.4510E-05 14029.70c 3.2757E-06 14030.70c 2.1593E-06
      50112.70c 1.6052E-08 50114.70c 1.0922E-08 50115.70c 5.6264E-09
      50116.70c 2.4061E-07 50117.70c 1.2709E-07 50118.70c 4.0080E-07
      50119.70c 1.4215E-07 50120.70c 5.3914E-07 50122.70c 7.6618E-08
      50124.70c 9.5814E-08 30000.70c 6.0084E-06
c      Total      8.0867E-02
mt61  lwtr.10t hwtr.10t al27.12t
c
c ----- Homogenized Grid Plate with Fuel Assembly Fitting -----
c      36.52% Water + 48.15% Al 1100 + 0.05% SS 304 + 15.28% Al 6061
m62   1001.70c 2.4333E-02 1002.70c 2.7987E-06 8016.70c 1.2163E-02
      8017.70c 4.6239E-06 13027.70c 3.7852E-02 6000.70c 8.1372E-08
      27059.70c 4.3874E-06 24050.70c 7.9286E-07 24052.70c 1.5289E-05

```

Fundamental - FUND

NRAD-FUND-RESR-001
CRIT-REAC-COEF

24053.70c	1.7337E-06	24054.70c	4.3156E-07	29063.70c	1.8130E-05	
29065.70c	8.0807E-06	26054.70c	4.7416E-06	26056.70c	7.4433E-05	
26057.70c	1.7190E-06	26058.70c	2.2876E-07	12024.70c	8.0758E-05	
12025.70c	1.0224E-05	12026.70c	1.1256E-05	25055.70c	7.4128E-06	
28058.70c	5.8334E-06	28060.70c	2.2470E-06	28061.70c	9.7676E-08	
28062.70c	3.1144E-07	28064.70c	7.9313E-08	15031.70c	1.7749E-08	
16032.70c	1.0849E-08	16033.70c	8.6856E-11	16034.70c	4.9028E-10	
16036.70c	2.2857E-12	14028.70c	1.1387E-04	14029.70c	5.7822E-06	
14030.70c	3.8116E-06	50112.70c	2.1128E-08	50114.70c	1.4376E-08	
50115.70c	7.4057E-09	50116.70c	3.1670E-07	50117.70c	1.6728E-07	
50118.70c	5.2754E-07	50119.70c	1.8710E-07	50120.70c	7.0964E-07	
50122.70c	1.0085E-07	50124.70c	1.2611E-07	22046.70c	3.2112E-07	
22047.70c	2.8959E-07	22048.70c	2.8695E-06	22049.70c	2.1058E-07	
22050.70c	2.0163E-07	30000.70c	1.0759E-05			
c	Total	7.4744E-02				
mt62	lwtr.10t	hwtr.10t	fe56.12t	al27.12t		
c						
c	----- Homogenized Grid Plate with Reflector Assembly Fitting -----					
c	24.28% Water + 48.15% Al 1100 + 12.24% Al 2011 + 0.05% SS 304 + 15.28% Al 6061					
m63	1001.70c	1.6176E-02	1002.70c	1.8605E-06	8016.70c	8.0859E-03
	8017.70c	3.0738E-06	13027.70c	4.5012E-02	83209.70c	3.9792E-06
	6000.70c	8.1372E-08	27059.70c	5.2694E-06	24050.70c	7.9286E-07
	24052.70c	1.5289E-05	24053.70c	1.7337E-06	24054.70c	4.3156E-07
	29063.70c	1.4259E-04	29065.70c	6.3555E-05	26054.70c	5.5031E-06
	26056.70c	8.6387E-05	26057.70c	1.9951E-06	26058.70c	2.6551E-07
	12024.70c	8.0758E-05	12025.70c	1.0224E-05	12026.70c	1.1256E-05
	25055.70c	7.4128E-06	28058.70c	6.4363E-06	28060.70c	2.4792E-06
	28061.70c	1.0777E-07	28062.70c	3.4362E-07	28064.70c	8.7510E-08
	15031.70c	1.7749E-08	82204.70c	5.6188E-08	82206.70c	9.6724E-07
	82207.70c	8.8697E-07	82208.70c	2.1030E-06	16032.70c	1.0849E-08
	16033.70c	8.6856E-11	16034.70c	4.9028E-10	16036.70c	2.2857E-12
	14028.70c	1.2753E-04	14029.70c	6.4755E-06	14030.70c	4.2687E-06
	50112.70c	2.5375E-08	50114.70c	1.7265E-08	50115.70c	8.8943E-09
	50116.70c	3.8036E-07	50117.70c	2.0091E-07	50118.70c	6.3359E-07
	50119.70c	2.2471E-07	50120.70c	8.5228E-07	50122.70c	1.2112E-07
	50124.70c	1.5146E-07	22046.70c	3.2112E-07	22047.70c	2.8959E-07
	22048.70c	2.8695E-06	22049.70c	2.1058E-07	22050.70c	2.0163E-07
	30000.70c	1.5528E-05				
c	Total	6.9890E-02				
mt63	lwtr.10t	hwtr.10t	fe56.12t	al27.12t		
c						
c	----- Homogenized Grid Plate with Beam Tube Support Fitting -----					
c	38.90% Water + 48.15% Al 1100 + 12.95% Al 6061					
m64	1001.70c	2.5923E-02	1002.70c	2.9815E-06	8016.70c	1.2958E-02
	8017.70c	4.9260E-06	13027.70c	3.6483E-02	27059.70c	4.2264E-06
	24050.70c	3.4304E-07	24052.70c	6.6151E-06	24053.70c	7.5010E-07
	24054.70c	1.8672E-07	29063.70c	1.6993E-05	29065.70c	7.5740E-06
	26054.70c	2.8271E-06	26056.70c	4.4380E-05	26057.70c	1.0249E-06
	26058.70c	1.3640E-07	12024.70c	6.8417E-05	12025.70c	8.6614E-06
	12026.70c	9.5362E-06	25055.70c	6.4496E-06	28058.70c	2.8891E-06
	28060.70c	1.1129E-06	28061.70c	4.8376E-08	28062.70c	1.5424E-07
	28064.70c	3.9281E-08	14028.70c	1.0599E-04	14029.70c	5.3818E-06
	14030.70c	3.5478E-06	50112.70c	2.0352E-08	50114.70c	1.3848E-08
	50115.70c	7.1337E-09	50116.70c	3.0507E-07	50117.70c	1.6114E-07
	50118.70c	5.0817E-07	50119.70c	1.8023E-07	50120.70c	6.8358E-07
	50122.70c	9.7145E-08	50124.70c	1.2148E-07	22046.70c	2.7205E-07
	22047.70c	2.4534E-07	22048.70c	2.4310E-06	22049.70c	1.7840E-07
	22050.70c	1.7081E-07	30000.70c	1.0033E-05		
c	Total	7.5685E-02				
mt64	lwtr.10t	hwtr.10t	al27.12t			
c						
c	----- Homogenized Al 6061 Core Support Structure -----					
c	55.28% Water + 44.72% Al 6061					
m65	1001.70c	3.6837E-02	1002.70c	4.2368E-06	8016.70c	1.8414E-02
	8017.70c	6.9999E-06	13027.70c	2.6201E-02	27059.70c	3.0843E-06
	24050.70c	1.1848E-06	24052.70c	2.2847E-05	24053.70c	2.5907E-06
	24054.70c	6.4487E-07	29063.70c	2.1764E-05	29065.70c	9.7006E-06
	26054.70c	2.6634E-06	26056.70c	4.1809E-05	26057.70c	9.6556E-07
	26058.70c	1.2850E-07	12024.70c	2.3630E-04	12025.70c	2.9915E-05
	12026.70c	3.2936E-05	25055.70c	9.9258E-06	28058.70c	2.1084E-06
	28060.70c	8.1216E-07	28061.70c	3.5304E-08	28062.70c	1.1256E-07
	28064.70c	2.8667E-08	14028.70c	1.4326E-04	14029.70c	7.2743E-06
	14030.70c	4.7953E-06	50112.70c	1.4853E-08	50114.70c	1.0106E-08
	50115.70c	5.2061E-09	50116.70c	2.2264E-07	50117.70c	1.1760E-07
	50118.70c	3.7086E-07	50119.70c	1.3153E-07	50120.70c	4.9887E-07
	50122.70c	7.0895E-08	50124.70c	8.8656E-08	22046.70c	9.3959E-07

Fundamental - FUND

NRAD-FUND-RESR-001
CRIT-REAC-COEF

```

22047.70c 8.4734E-07 22048.70c 8.3960E-06 22049.70c 6.1615E-07
22050.70c 5.8995E-07 30000.70c 1.3899E-05
c Total 8.2064E-02
mt65 lwtr.10t hwtr.10t al27.12t
c
c ----- Al 6061 Mounting Pad and Tank -----
m66 13027.70c 5.8593E-02 24050.70c 2.6495E-06 24052.70c 5.1093E-05
24053.70c 5.7936E-06 24054.70c 1.4421E-06 29063.70c 4.8671E-05
29065.70c 2.1694E-05 12024.70c 5.2843E-04 12025.70c 6.6898E-05
12026.70c 7.3655E-05 25055.70c 2.2197E-05 14028.70c 3.2037E-04
14029.70c 1.6268E-05 14030.70c 1.0724E-05 26054.70c 5.9561E-06
26056.70c 9.3499E-05 26057.70c 2.1593E-06 26058.70c 2.8736E-07
30000.70c 3.1082E-05 22046.70c 2.1012E-06 22047.70c 1.8949E-06
22048.70c 1.8776E-05 22049.70c 1.3779E-06 22050.70c 1.3193E-06
27059.70c 6.8975E-06 28058.70c 4.7151E-06 28060.70c 1.8162E-06
28061.70c 7.8950E-08 28062.70c 2.5173E-07 28064.70c 6.4108E-08
50112.70c 3.3215E-08 50114.70c 2.2600E-08 50115.70c 1.1642E-08
50116.70c 4.9788E-07 50117.70c 2.6298E-07 50118.70c 8.2935E-07
50119.70c 2.9414E-07 50120.70c 1.1156E-06 50122.70c 1.5854E-07
50124.70c 1.9826E-07
c Total 5.9939E-02
mt66 al27.12t
c
c --- UErZrH Fuel -----
c ----- Fuel Rod : 11752 -----
m101 92234.70c 9.9035E-06 92235.70c 1.0820E-03 92236.70c 1.2002E-05
92238.70c 4.3193E-03 5010.70c 7.6187E-08 5011.70c 3.0666E-07
1001.70c 5.0609E-02 1002.70c 5.8207E-06 6000.70c 1.1128E-03
40090.70c 1.6481E-02 40091.70c 3.5941E-03 40092.70c 5.4936E-03
40094.70c 5.5673E-03 40096.70c 8.9692E-04 68162.70c 3.1036E-07
68164.70c 3.5691E-06 68166.70c 7.4507E-05 68167.70c 5.0832E-05
68168.70c 5.9367E-05 68170.70c 3.3097E-05 72174.70c 1.3203E-09
72176.70c 4.3404E-08 72177.70c 1.5348E-07 72178.70c 2.2511E-07
72179.70c 1.1239E-07 72180.70c 2.8947E-07
c Total 8.9406E-02
mt101 h/zr.10t zr/h.10t
c
c ----- Fuel Rod : 11753 -----
m102 92234.70c 9.9461E-06 92235.70c 1.0865E-03 92236.70c 1.2053E-05
92238.70c 4.3380E-03 5010.70c 7.6216E-08 5011.70c 3.0678E-07
1001.70c 5.0542E-02 1002.70c 5.8130E-06 6000.70c 1.1132E-03
40090.70c 1.6459E-02 40091.70c 3.5893E-03 40092.70c 5.4864E-03
40094.70c 5.5600E-03 40096.70c 8.9574E-04 68162.70c 3.1047E-07
68164.70c 3.5704E-06 68166.70c 7.4535E-05 68167.70c 5.0851E-05
68168.70c 5.9389E-05 68170.70c 3.3110E-05 72174.70c 1.3185E-09
72176.70c 4.3347E-08 72177.70c 1.5328E-07 72178.70c 2.2481E-07
72179.70c 1.1224E-07 72180.70c 2.8909E-07
c Total 8.9321E-02
mt102 h/zr.10t zr/h.10t
c
c ----- Fuel Rod : 11754 -----
m103 92234.70c 9.9494E-06 92235.70c 1.0868E-03 92236.70c 1.2057E-05
92238.70c 4.3395E-03 5010.70c 7.6241E-08 5011.70c 3.0688E-07
1001.70c 5.0559E-02 1002.70c 5.8149E-06 6000.70c 1.1136E-03
40090.70c 1.6465E-02 40091.70c 3.5905E-03 40092.70c 5.4882E-03
40094.70c 5.5618E-03 40096.70c 8.9603E-04 68162.70c 3.1057E-07
68164.70c 3.5716E-06 68166.70c 7.4560E-05 68167.70c 5.0868E-05
68168.70c 5.9408E-05 68170.70c 3.3121E-05 72174.70c 1.3190E-09
72176.70c 4.3361E-08 72177.70c 1.5333E-07 72178.70c 2.2488E-07
72179.70c 1.1228E-07 72180.70c 2.8918E-07
c Total 8.9350E-02
mt103 h/zr.10t zr/h.10t
c
c ----- Fuel Rod : 11755 -----
m104 92234.70c 9.9421E-06 92235.70c 1.0861E-03 92236.70c 1.2048E-05
92238.70c 4.3363E-03 5010.70c 7.6186E-08 5011.70c 3.0666E-07
1001.70c 5.0836E-02 1002.70c 5.8469E-06 6000.70c 1.1128E-03
40090.70c 1.6451E-02 40091.70c 3.5876E-03 40092.70c 5.4837E-03
40094.70c 5.5572E-03 40096.70c 8.9529E-04 68162.70c 3.1035E-07
68164.70c 3.5690E-06 68166.70c 7.4506E-05 68167.70c 5.0831E-05
68168.70c 5.9366E-05 68170.70c 3.3097E-05 72174.70c 1.3179E-09
72176.70c 4.3325E-08 72177.70c 1.5320E-07 72178.70c 2.2470E-07
72179.70c 1.1218E-07 72180.70c 2.8894E-07
c Total 8.9597E-02
mt104 h/zr.10t zr/h.10t
c

```

Fundamental - FUND

NRAD-FUND-RESR-001
CRIT-REAC-COEF

```

c ----- Fuel Rod : 11756 -----
m105 92234.70c 9.9470E-06 92235.70c 1.0865E-03 92236.70c 1.2054E-05 ---
      92238.70c 4.3385E-03 5010.70c 7.6223E-08 5011.70c 3.0681E-07
      1001.70c 5.0547E-02 1002.70c 5.8135E-06 6000.70c 1.1133E-03
      40090.70c 1.6461E-02 40091.70c 3.5897E-03 40092.70c 5.4869E-03
      40094.70c 5.5605E-03 40096.70c 8.9582E-04 68162.70c 3.1050E-07
      68164.70c 3.5708E-06 68166.70c 7.4543E-05 68167.70c 5.0856E-05
      68168.70c 5.9394E-05 68170.70c 3.3113E-05 72174.70c 1.3187E-09
      72176.70c 4.3351E-08 72177.70c 1.5329E-07 72178.70c 2.2483E-07
      72179.70c 1.1225E-07 72180.70c 2.8912E-07
c      Total 8.9329E-02
mt105 h/zr.10t zr/h.10t
c
c ----- Fuel Rod : 11757 -----
m106 92234.70c 9.9425E-06 92235.70c 1.0861E-03 92236.70c 1.2049E-05 ---
      92238.70c 4.3365E-03 5010.70c 7.6189E-08 5011.70c 3.0667E-07
      1001.70c 5.0524E-02 1002.70c 5.8109E-06 6000.70c 1.1128E-03
      40090.70c 1.6453E-02 40091.70c 3.5881E-03 40092.70c 5.4844E-03
      40094.70c 5.5580E-03 40096.70c 8.9542E-04 68162.70c 3.1036E-07
      68164.70c 3.5692E-06 68166.70c 7.4509E-05 68167.70c 5.0833E-05
      68168.70c 5.9368E-05 68170.70c 3.3098E-05 72174.70c 1.3181E-09
      72176.70c 4.3331E-08 72177.70c 1.5322E-07 72178.70c 2.2473E-07
      72179.70c 1.1220E-07 72180.70c 2.8899E-07
c      Total 8.9289E-02
mt106 h/zr.10t zr/h.10t
c
c ----- Fuel Rod : 11758 -----
m107 92234.70c 9.9454E-06 92235.70c 1.0864E-03 92236.70c 1.2052E-05 ---
      92238.70c 4.3377E-03 5010.70c 7.6211E-08 5011.70c 3.0676E-07
      1001.70c 5.0853E-02 1002.70c 5.8488E-06 6000.70c 1.1131E-03
      40090.70c 1.6456E-02 40091.70c 3.5887E-03 40092.70c 5.4854E-03
      40094.70c 5.5590E-03 40096.70c 8.9558E-04 68162.70c 3.1045E-07
      68164.70c 3.5702E-06 68166.70c 7.4531E-05 68167.70c 5.0848E-05
      68168.70c 5.9385E-05 68170.70c 3.3107E-05 72174.70c 1.3183E-09
      72176.70c 4.3339E-08 72177.70c 1.5325E-07 72178.70c 2.2477E-07
      72179.70c 1.1222E-07 72180.70c 2.8904E-07
c      Total 8.9626E-02
mt107 h/zr.10t zr/h.10t
c
c ----- Fuel Rod : 11759 -----
m108 92234.70c 9.9408E-06 92235.70c 1.0859E-03 92236.70c 1.2047E-05 ---
      92238.70c 4.3357E-03 5010.70c 7.6175E-08 5011.70c 3.0662E-07
      1001.70c 5.1143E-02 1002.70c 5.8822E-06 6000.70c 1.1126E-03
      40090.70c 1.6447E-02 40091.70c 3.5867E-03 40092.70c 5.4823E-03
      40094.70c 5.5558E-03 40096.70c 8.9507E-04 68162.70c 3.1031E-07
      68164.70c 3.5685E-06 68166.70c 7.4496E-05 68167.70c 5.0824E-05
      68168.70c 5.9357E-05 68170.70c 3.3092E-05 72174.70c 1.3175E-09
      72176.70c 4.3314E-08 72177.70c 1.5316E-07 72178.70c 2.2464E-07
      72179.70c 1.1216E-07 72180.70c 2.8887E-07
c      Total 8.9895E-02
mt108 h/zr.10t zr/h.10t
c
c ----- Fuel Rod : 11760 -----
m109 92234.70c 9.9557E-06 92235.70c 1.0874E-03 92236.70c 1.2065E-05 ---
      92238.70c 4.3423E-03 5010.70c 7.6333E-08 5011.70c 3.0725E-07
      1001.70c 5.0265E-02 1002.70c 5.7812E-06 6000.70c 1.1868E-03
      40090.70c 1.6473E-02 40091.70c 3.5924E-03 40092.70c 5.4911E-03
      40094.70c 5.5648E-03 40096.70c 8.9651E-04 68162.70c 3.2902E-07
      68164.70c 3.7838E-06 68166.70c 7.8989E-05 68167.70c 5.3890E-05
      68168.70c 6.2938E-05 68170.70c 3.5088E-05 72174.70c 1.3197E-09
      72176.70c 4.3384E-08 72177.70c 1.5341E-07 72178.70c 2.2500E-07
      72179.70c 1.1234E-07 72180.70c 2.8934E-07
c      Total 8.9164E-02
mt109 h/zr.10t zr/h.10t
c
c ----- Fuel Rod : 11761 -----
m110 92234.70c 9.9210E-06 92235.70c 1.0826E-03 92236.70c 1.2023E-05 ---
      92238.70c 4.3282E-03 5010.70c 7.6279E-08 5011.70c 3.0703E-07
      1001.70c 5.0313E-02 1002.70c 5.7867E-06 6000.70c 1.1141E-03
      40090.70c 1.6489E-02 40091.70c 3.5959E-03 40092.70c 5.4963E-03
      40094.70c 5.5701E-03 40096.70c 8.9736E-04 68162.70c 3.2518E-07
      68164.70c 3.7396E-06 68166.70c 7.8067E-05 68167.70c 5.3260E-05
      68168.70c 6.2203E-05 68170.70c 3.4678E-05 72174.70c 1.3209E-09
      72176.70c 4.3425E-08 72177.70c 1.5356E-07 72178.70c 2.2522E-07
      72179.70c 1.1244E-07 72180.70c 2.8961E-07
c      Total 8.9148E-02

```

Fundamental - FUND

NRAD-FUND-RESR-001
CRIT-REAC-COEF

```

mt110 h/zr.10t zr/h.10t
c
c ----- Fuel Rod : 11762 -----
m111 92234.70c 9.9355E-06 92235.70c 1.0835E-03 92236.70c 1.2040E-05
      92238.70c 4.3352E-03 5010.70c 7.6390E-08 5011.70c 3.0748E-07
      1001.70c 5.0400E-02 1002.70c 5.7967E-06 6000.70c 1.0437E-03
      40090.70c 1.6518E-02 40091.70c 3.6021E-03 40092.70c 5.5059E-03
      40094.70c 5.5797E-03 40096.70c 8.9892E-04 68162.70c 3.2565E-07
      68164.70c 3.7450E-06 68166.70c 7.8180E-05 68167.70c 5.3337E-05
      68168.70c 6.2293E-05 68170.70c 3.4729E-05 72174.70c 1.3232E-09
      72176.70c 4.3501E-08 72177.70c 1.5382E-07 72178.70c 2.2561E-07
      72179.70c 1.1264E-07 72180.70c 2.9011E-07
c
c Total 8.9229E-02
mt111 h/zr.10t zr/h.10t
c
c ----- Fuel Rod : 11763 -----
m112 92234.70c 9.9392E-06 92235.70c 1.0839E-03 92236.70c 1.2045E-05
      92238.70c 4.3369E-03 5010.70c 7.6419E-08 5011.70c 3.0760E-07
      1001.70c 5.0736E-02 1002.70c 5.8353E-06 6000.70c 1.0441E-03
      40090.70c 1.6522E-02 40091.70c 3.6031E-03 40092.70c 5.5074E-03
      40094.70c 5.5813E-03 40096.70c 8.9917E-04 68162.70c 3.2578E-07
      68164.70c 3.7464E-06 68166.70c 7.8210E-05 68167.70c 5.3358E-05
      68168.70c 6.2317E-05 68170.70c 3.4742E-05 72174.70c 1.3236E-09
      72176.70c 4.3513E-08 72177.70c 1.5387E-07 72178.70c 2.2567E-07
      72179.70c 1.1267E-07 72180.70c 2.9020E-07
c
c Total 8.9575E-02
mt112 h/zr.10t zr/h.10t
c
c ----- Fuel Rod : 11764 -----
m113 92234.70c 9.9328E-06 92235.70c 1.0832E-03 92236.70c 1.2037E-05
      92238.70c 4.3341E-03 5010.70c 7.6369E-08 5011.70c 3.0740E-07
      1001.70c 5.1018E-02 1002.70c 5.8677E-06 6000.70c 1.0435E-03
      40090.70c 1.6510E-02 40091.70c 3.6004E-03 40092.70c 5.5032E-03
      40094.70c 5.5770E-03 40096.70c 8.9848E-04 68162.70c 3.2557E-07
      68164.70c 3.7440E-06 68166.70c 7.8159E-05 68167.70c 5.3323E-05
      68168.70c 6.2276E-05 68170.70c 3.4719E-05 72174.70c 1.3226E-09
      72176.70c 4.3480E-08 72177.70c 1.5375E-07 72178.70c 2.2550E-07
      72179.70c 1.1258E-07 72180.70c 2.8997E-07
c
c Total 8.9829E-02
mt113 h/zr.10t zr/h.10t
c
c ----- Fuel Rod : 11765 -----
m114 92234.70c 9.9299E-06 92235.70c 1.0828E-03 92236.70c 1.2033E-05
      92238.70c 4.3328E-03 5010.70c 7.6347E-08 5011.70c 3.0730E-07
      1001.70c 5.1002E-02 1002.70c 5.8660E-06 6000.70c 1.0432E-03
      40090.70c 1.6505E-02 40091.70c 3.5993E-03 40092.70c 5.5016E-03
      40094.70c 5.5753E-03 40096.70c 8.9821E-04 68162.70c 3.2547E-07
      68164.70c 3.7429E-06 68166.70c 7.8136E-05 68167.70c 5.3307E-05
      68168.70c 6.2258E-05 68170.70c 3.4709E-05 72174.70c 1.3222E-09
      72176.70c 4.3467E-08 72177.70c 1.5370E-07 72178.70c 2.2543E-07
      72179.70c 1.1255E-07 72180.70c 2.8989E-07
c
c Total 8.9802E-02
mt114 h/zr.10t zr/h.10t
c
c ----- Fuel Rod : 11766 -----
m115 92234.70c 9.9374E-06 92235.70c 1.0836E-03 92236.70c 1.2043E-05
      92238.70c 4.3361E-03 5010.70c 7.6405E-08 5011.70c 3.0754E-07
      1001.70c 5.0726E-02 1002.70c 5.8342E-06 6000.70c 1.0440E-03
      40090.70c 1.6519E-02 40091.70c 3.6024E-03 40092.70c 5.5064E-03
      40094.70c 5.5802E-03 40096.70c 8.9900E-04 68162.70c 3.2572E-07
      68164.70c 3.7458E-06 68166.70c 7.8196E-05 68167.70c 5.3348E-05
      68168.70c 6.2305E-05 68170.70c 3.4735E-05 72174.70c 1.3233E-09
      72176.70c 4.3505E-08 72177.70c 1.5384E-07 72178.70c 2.2563E-07
      72179.70c 1.1265E-07 72180.70c 2.9014E-07
c
c Total 8.9559E-02
mt115 h/zr.10t zr/h.10t
c
c ----- Fuel Rod : 11767 -----
m116 92234.70c 9.9272E-06 92235.70c 1.0826E-03 92236.70c 1.2030E-05
      92238.70c 4.3316E-03 5010.70c 7.6327E-08 5011.70c 3.0723E-07
      1001.70c 5.0359E-02 1002.70c 5.7920E-06 6000.70c 1.0429E-03
      40090.70c 1.6504E-02 40091.70c 3.5992E-03 40092.70c 5.5014E-03
      40094.70c 5.5752E-03 40096.70c 8.9818E-04 68162.70c 3.2539E-07
      68164.70c 3.7419E-06 68166.70c 7.8116E-05 68167.70c 5.3294E-05
      68168.70c 6.2242E-05 68170.70c 3.4700E-05 72174.70c 1.3221E-09
      72176.70c 4.3465E-08 72177.70c 1.5370E-07 72178.70c 2.2542E-07

```

Fundamental - FUND

NRAD-FUND-RESR-001
CRIT-REAC-COEF

	72179.70c	1.1255E-07	72180.70c	2.8988E-07	
c	Total 8.9156E-02				
mt116	h/zr.10t	zr/h.10t			
c					
c	----- Fuel Rod : 11768 -----				---
m117	92234.70c	9.9193E-06	92235.70c	1.0832E-03	92236.70c 1.2021E-05
	92238.70c	4.3267E-03	5010.70c	7.6224E-08	5011.70c 3.0681E-07
	1001.70c	5.0293E-02	1002.70c	5.7844E-06	6000.70c 1.0056E-03
	40090.70c	1.6483E-02	40091.70c	3.5944E-03	40092.70c 5.4942E-03
	40094.70c	5.5679E-03	40096.70c	8.9701E-04	68162.70c 3.2133E-07
	68164.70c	3.6953E-06	68166.70c	7.7143E-05	68167.70c 5.2630E-05
	68168.70c	6.1467E-05	68170.70c	3.4268E-05	72174.70c 1.3204E-09
	72176.70c	4.3408E-08	72177.70c	1.5350E-07	72178.70c 2.2513E-07
	72179.70c	1.1240E-07	72180.70c	2.8950E-07	
c	Total 8.9003E-02				
mt117	h/zr.10t	zr/h.10t			
c					
c	----- Fuel Rod : 11769 -----				---
m118	92234.70c	9.9035E-06	92235.70c	1.0814E-03	92236.70c 1.2002E-05
	92238.70c	4.3199E-03	5010.70c	7.6102E-08	5011.70c 3.0632E-07
	1001.70c	5.0206E-02	1002.70c	5.7743E-06	6000.70c 1.0398E-03
	40090.70c	1.6454E-02	40091.70c	3.5882E-03	40092.70c 5.4846E-03
	40094.70c	5.5582E-03	40096.70c	8.9545E-04	68162.70c 3.2082E-07
	68164.70c	3.6894E-06	68166.70c	7.7020E-05	68167.70c 5.2546E-05
	68168.70c	6.1368E-05	68170.70c	3.4213E-05	72174.70c 1.3181E-09
	72176.70c	4.3333E-08	72177.70c	1.5323E-07	72178.70c 2.2474E-07
	72179.70c	1.1220E-07	72180.70c	2.8899E-07	
c	Total 8.8885E-02				
mt118	h/zr.10t	zr/h.10t			
c					
c	----- Fuel Rod : 11770 -----				---
m119	92234.70c	9.9257E-06	92235.70c	1.0839E-03	92236.70c 1.2028E-05
	92238.70c	4.3294E-03	5010.70c	7.6273E-08	5011.70c 3.0701E-07
	1001.70c	5.0949E-02	1002.70c	5.8598E-06	6000.70c 1.0422E-03
	40090.70c	1.6487E-02	40091.70c	3.5955E-03	40092.70c 5.4958E-03
	40094.70c	5.5695E-03	40096.70c	8.9727E-04	68162.70c 3.2154E-07
	68164.70c	3.6977E-06	68166.70c	7.7193E-05	68167.70c 5.2664E-05
	68168.70c	6.1507E-05	68170.70c	3.4290E-05	72174.70c 1.3208E-09
	72176.70c	4.3421E-08	72177.70c	1.5354E-07	72178.70c 2.2519E-07
	72179.70c	1.1243E-07	72180.70c	2.8958E-07	
c	Total 8.9709E-02				
mt119	h/zr.10t	zr/h.10t			
c					
c	----- Fuel Rod : 11771 -----				---
m120	92234.70c	9.9124E-06	92235.70c	1.0824E-03	92236.70c 1.2012E-05
	92238.70c	4.3238E-03	5010.70c	7.6169E-08	5011.70c 3.0659E-07
	1001.70c	5.0565E-02	1002.70c	5.8156E-06	6000.70c 1.0407E-03
	40090.70c	1.6467E-02	40091.70c	3.5910E-03	40092.70c 5.4889E-03
	40094.70c	5.5625E-03	40096.70c	8.9614E-04	68162.70c 3.2111E-07
	68164.70c	3.6927E-06	68166.70c	7.7088E-05	68167.70c 5.2593E-05
	68168.70c	6.1423E-05	68170.70c	3.4244E-05	72174.70c 1.3191E-09
	72176.70c	4.3366E-08	72177.70c	1.5335E-07	72178.70c 2.2491E-07
	72179.70c	1.1229E-07	72180.70c	2.8922E-07	
c	Total 8.9275E-02				
mt120	h/zr.10t	zr/h.10t			
c					
c	----- Fuel Rod : 11772 -----				---
m121	92234.70c	9.9263E-06	92235.70c	1.0839E-03	92236.70c 1.2029E-05
	92238.70c	4.3298E-03	5010.70c	7.6277E-08	5011.70c 3.0702E-07
	1001.70c	5.0321E-02	1002.70c	5.7876E-06	6000.70c 1.0422E-03
	40090.70c	1.6492E-02	40091.70c	3.5964E-03	40092.70c 5.4972E-03
	40094.70c	5.5709E-03	40096.70c	8.9750E-04	68162.70c 3.2156E-07
	68164.70c	3.6979E-06	68166.70c	7.7197E-05	68167.70c 5.2667E-05
	68168.70c	6.1509E-05	68170.70c	3.4292E-05	72174.70c 1.3211E-09
	72176.70c	4.3432E-08	72177.70c	1.5358E-07	72178.70c 2.2525E-07
	72179.70c	1.1246E-07	72180.70c	2.8966E-07	
c	Total 8.9089E-02				
mt121	h/zr.10t	zr/h.10t			
c					
c	----- Fuel Rod : 11773 -----				---
m122	92234.70c	9.9165E-06	92235.70c	1.0829E-03	92236.70c 1.2017E-05
	92238.70c	4.3255E-03	5010.70c	7.6200E-08	5011.70c 3.0672E-07
	1001.70c	5.0585E-02	1002.70c	5.8180E-06	6000.70c 1.0412E-03
	40090.70c	1.6473E-02	40091.70c	3.5924E-03	40092.70c 5.4911E-03
	40094.70c	5.5647E-03	40096.70c	8.9650E-04	68162.70c 3.2124E-07
	68164.70c	3.6942E-06	68166.70c	7.7120E-05	68167.70c 5.2614E-05

Fundamental - FUND

NRAD-FUND-RESR-001
CRIT-REAC-COEF

	68168.70c	6.1448E-05	68170.70c	3.4258E-05	72174.70c	1.3197E-09
	72176.70c	4.3384E-08	72177.70c	1.5341E-07	72178.70c	2.2500E-07
	72179.70c	1.1234E-07	72180.70c	2.8933E-07		
c	Total 8.9311E-02					
mt122	h/zr.10t zr/h.10t					
c						
c	----- Fuel Rod : 11774 -----					
m123	92234.70c	9.9213E-06	92235.70c	1.0834E-03	92236.70c	1.2023E-05
	92238.70c	4.3276E-03	5010.70c	7.6239E-08	5011.70c	3.0687E-07
	1001.70c	5.1555E-02	1002.70c	5.9295E-06	6000.70c	1.0417E-03
	40090.70c	1.6476E-02	40091.70c	3.5931E-03	40092.70c	5.4921E-03
	40094.70c	5.5658E-03	40096.70c	8.9667E-04	68162.70c	3.2140E-07
	68164.70c	3.6961E-06	68166.70c	7.7159E-05	68167.70c	5.2640E-05
	68168.70c	6.1479E-05	68170.70c	3.4275E-05	72174.70c	1.3199E-09
	72176.70c	4.3392E-08	72177.70c	1.5344E-07	72178.70c	2.2504E-07
	72179.70c	1.1236E-07	72180.70c	2.8939E-07		
c	Total 9.0290E-02					
mt123	h/zr.10t zr/h.10t					
c						
c	----- Fuel Rod : 11775 -----					
m124	92234.70c	9.8993E-06	92235.70c	1.0809E-03	92236.70c	1.1996E-05
	92238.70c	4.3181E-03	5010.70c	7.6154E-08	5011.70c	3.0653E-07
	1001.70c	5.0564E-02	1002.70c	5.8156E-06	6000.70c	1.0405E-03
	40090.70c	1.6467E-02	40091.70c	3.5909E-03	40092.70c	5.4888E-03
	40094.70c	5.5625E-03	40096.70c	8.9614E-04	68162.70c	3.2826E-07
	68164.70c	3.7749E-06	68166.70c	7.8805E-05	68167.70c	5.3764E-05
	68168.70c	6.2791E-05	68170.70c	3.5006E-05	72174.70c	1.3191E-09
	72176.70c	4.3366E-08	72177.70c	1.5335E-07	72178.70c	2.2491E-07
	72179.70c	1.1229E-07	72180.70c	2.8922E-07		
c	Total 8.9272E-02					
mt124	h/zr.10t zr/h.10t					
c						
c	----- Fuel Rod : 11776 -----					
m125	92234.70c	9.9241E-06	92235.70c	1.0826E-03	92236.70c	1.2026E-05
	92238.70c	4.3299E-03	5010.70c	7.6428E-08	5011.70c	3.0763E-07
	1001.70c	5.1071E-02	1002.70c	5.8739E-06	6000.70c	1.0803E-03
	40090.70c	1.6527E-02	40091.70c	3.6041E-03	40092.70c	5.5090E-03
	40094.70c	5.5829E-03	40096.70c	8.9943E-04	68162.70c	3.3306E-07
	68164.70c	3.8302E-06	68166.70c	7.9957E-05	68167.70c	5.4550E-05
	68168.70c	6.3709E-05	68170.70c	3.5518E-05	72174.70c	1.3240E-09
	72176.70c	4.3525E-08	72177.70c	1.5391E-07	72178.70c	2.2574E-07
	72179.70c	1.1270E-07	72180.70c	2.9028E-07		
c	Total 8.9953E-02					
mt125	h/zr.10t zr/h.10t					
c						
c	----- Fuel Rod : 11777 -----					
m126	92234.70c	9.8531E-06	92235.70c	1.0752E-03	92236.70c	1.1940E-05
	92238.70c	4.2986E-03	5010.70c	7.6180E-08	5011.70c	3.0663E-07
	1001.70c	5.0691E-02	1002.70c	5.8301E-06	6000.70c	1.0768E-03
	40090.70c	1.6508E-02	40091.70c	3.5999E-03	40092.70c	5.5026E-03
	40094.70c	5.5764E-03	40096.70c	8.9838E-04	68162.70c	3.2476E-07
	68164.70c	3.7347E-06	68166.70c	7.7965E-05	68167.70c	5.3191E-05
	68168.70c	6.2122E-05	68170.70c	3.4633E-05	72174.70c	1.3224E-09
	72176.70c	4.3475E-08	72177.70c	1.5373E-07	72178.70c	2.2547E-07
	72179.70c	1.1257E-07	72180.70c	2.8994E-07		
c	Total 8.9487E-02					
mt126	h/zr.10t zr/h.10t					
c						
c	----- Fuel Rod : 11778 -----					
m127	92234.70c	9.9231E-06	92235.70c	1.0825E-03	92236.70c	1.2025E-05
	92238.70c	4.3294E-03	5010.70c	7.6294E-08	5011.70c	3.0709E-07
	1001.70c	5.0623E-02	1002.70c	5.8223E-06	6000.70c	1.1503E-03
	40090.70c	1.6485E-02	40091.70c	3.5951E-03	40092.70c	5.4951E-03
	40094.70c	5.5688E-03	40096.70c	8.9717E-04	68162.70c	3.2886E-07
	68164.70c	3.7819E-06	68166.70c	7.8949E-05	68167.70c	5.3862E-05
	68168.70c	6.2906E-05	68170.70c	3.5070E-05	72174.70c	1.3206E-09
	72176.70c	4.3416E-08	72177.70c	1.5352E-07	72178.70c	2.2517E-07
	72179.70c	1.1242E-07	72180.70c	2.8955E-07		
c	Total 8.9490E-02					
mt127	h/zr.10t zr/h.10t					
c						
c	----- Fuel Rod : 11779 -----					
m128	92234.70c	9.8496E-06	92235.70c	1.0748E-03	92236.70c	1.1936E-05
	92238.70c	4.2971E-03	5010.70c	7.6154E-08	5011.70c	3.0653E-07
	1001.70c	5.0674E-02	1002.70c	5.8282E-06	6000.70c	1.0764E-03
	40090.70c	1.6502E-02	40091.70c	3.5988E-03	40092.70c	5.5008E-03

Fundamental - FUND

NRAD-FUND-RESR-001
CRIT-REAC-COEF

	40094.70c	5.5745E-03	40096.70c	8.9809E-04	68162.70c	3.2465E-07
	68164.70c	3.7335E-06	68166.70c	7.7939E-05	68167.70c	5.3173E-05
	68168.70c	6.2101E-05	68170.70c	3.4621E-05	72174.70c	1.3220E-09
	72176.70c	4.3460E-08	72177.70c	1.5368E-07	72178.70c	2.2540E-07
	72179.70c	1.1253E-07	72180.70c	2.8985E-07		
c	Total 8.9458E-02					
mt128	h/zr.10t	zr/h.10t				
c						
c	----- Fuel Rod : 11780 -----					
m129	92234.70c	9.9194E-06	92235.70c	1.0821E-03	92236.70c	1.2021E-05
	92238.70c	4.3279E-03	5010.70c	7.6267E-08	5011.70c	3.0698E-07
	1001.70c	5.0290E-02	1002.70c	5.7841E-06	6000.70c	1.1499E-03
	40090.70c	1.6482E-02	40091.70c	3.5942E-03	40092.70c	5.4939E-03
	40094.70c	5.5675E-03	40096.70c	8.9696E-04	68162.70c	3.2874E-07
	68164.70c	3.7805E-06	68166.70c	7.8922E-05	68167.70c	5.3843E-05
	68168.70c	6.2884E-05	68170.70c	3.5058E-05	72174.70c	1.3203E-09
	72176.70c	4.3406E-08	72177.70c	1.5349E-07	72178.70c	2.2512E-07
	72179.70c	1.1239E-07	72180.70c	2.8948E-07		
c	Total 8.9148E-02					
mt129	h/zr.10t	zr/h.10t				
c						
c	----- Fuel Rod : 11781 -----					
m130	92234.70c	9.8850E-06	92235.70c	1.0789E-03	92236.70c	1.1979E-05
	92238.70c	4.3122E-03	5010.70c	7.6155E-08	5011.70c	3.0653E-07
	1001.70c	5.0582E-02	1002.70c	5.8176E-06	6000.70c	1.0764E-03
	40090.70c	1.6472E-02	40091.70c	3.5922E-03	40092.70c	5.4908E-03
	40094.70c	5.5644E-03	40096.70c	8.9645E-04	68162.70c	3.3187E-07
	68164.70c	3.8165E-06	68166.70c	7.9672E-05	68167.70c	5.4355E-05
	68168.70c	6.3481E-05	68170.70c	3.5391E-05	72174.70c	1.3196E-09
	72176.70c	4.3381E-08	72177.70c	1.5340E-07	72178.70c	2.2499E-07
	72179.70c	1.1233E-07	72180.70c	2.8932E-07		
c	Total 8.9332E-02					
mt130	h/zr.10t	zr/h.10t				
c						
c	----- Fuel Rod : 11782 -----					
m131	92234.70c	9.9487E-06	92235.70c	1.0858E-03	92236.70c	1.2056E-05
	92238.70c	4.3401E-03	5010.70c	7.6280E-08	5011.70c	3.0704E-07
	1001.70c	5.0260E-02	1002.70c	5.7806E-06	6000.70c	1.1141E-03
	40090.70c	1.6472E-02	40091.70c	3.5921E-03	40092.70c	5.4906E-03
	40094.70c	5.5642E-03	40096.70c	8.9642E-04	68162.70c	3.2157E-07
	68164.70c	3.6981E-06	68166.70c	7.7200E-05	68167.70c	5.2669E-05
	68168.70c	6.1512E-05	68170.70c	3.4293E-05	72174.70c	1.3195E-09
	72176.70c	4.3380E-08	72177.70c	1.5340E-07	72178.70c	2.2498E-07
	72179.70c	1.1233E-07	72180.70c	2.8931E-07		
c	Total 8.9074E-02					
mt131	h/zr.10t	zr/h.10t				
c						
c	----- Fuel Rod : 11783 -----					
m132	92234.70c	9.9499E-06	92235.70c	1.0859E-03	92236.70c	1.2058E-05
	92238.70c	4.3407E-03	5010.70c	7.6289E-08	5011.70c	3.0707E-07
	1001.70c	5.0266E-02	1002.70c	5.7812E-06	6000.70c	1.1143E-03
	40090.70c	1.6474E-02	40091.70c	3.5925E-03	40092.70c	5.4912E-03
	40094.70c	5.5648E-03	40096.70c	8.9652E-04	68162.70c	3.2161E-07
	68164.70c	3.6985E-06	68166.70c	7.7209E-05	68167.70c	5.2675E-05
	68168.70c	6.1519E-05	68170.70c	3.4297E-05	72174.70c	1.3197E-09
	72176.70c	4.3385E-08	72177.70c	1.5341E-07	72178.70c	2.2501E-07
	72179.70c	1.1234E-07	72180.70c	2.8934E-07		
c	Total 8.9084E-02					
mt132	h/zr.10t	zr/h.10t				
c						
c	----- Fuel Rod : 11784 -----					
m133	92234.70c	9.9602E-06	92235.70c	1.0871E-03	92236.70c	1.2070E-05
	92238.70c	4.3451E-03	5010.70c	7.6367E-08	5011.70c	3.0739E-07
	1001.70c	5.0317E-02	1002.70c	5.7871E-06	6000.70c	1.1154E-03
	40090.70c	1.6490E-02	40091.70c	3.5961E-03	40092.70c	5.4967E-03
	40094.70c	5.5705E-03	40096.70c	8.9743E-04	68162.70c	3.2194E-07
	68164.70c	3.7023E-06	68166.70c	7.7288E-05	68167.70c	5.2729E-05
	68168.70c	6.1582E-05	68170.70c	3.4332E-05	72174.70c	1.3210E-09
	72176.70c	4.3428E-08	72177.70c	1.5357E-07	72178.70c	2.2523E-07
	72179.70c	1.1245E-07	72180.70c	2.8963E-07		
c	Total 8.9174E-02					
mt133	h/zr.10t	zr/h.10t				
c						
c	----- Fuel Rod : 11785 -----					
m134	92234.70c	9.9643E-06	92235.70c	1.0881E-03	92236.70c	1.2075E-05
	92238.70c	4.3464E-03	5010.70c	7.6356E-08	5011.70c	3.0734E-07

Fundamental - FUND

NRAD-FUND-RESR-001
CRIT-REAC-COEF

1001.70c	5.0283E-02	1002.70c	5.7832E-06	6000.70c	1.1512E-03	
40090.70c	1.6479E-02	40091.70c	3.5937E-03	40092.70c	5.4931E-03	
40094.70c	5.5667E-03	40096.70c	8.9683E-04	68162.70c	3.2551E-07	
68164.70c	3.7434E-06	68166.70c	7.8145E-05	68167.70c	5.3314E-05	
68168.70c	6.2265E-05	68170.70c	3.4713E-05	72174.70c	1.3201E-09	
72176.70c	4.3399E-08	72177.70c	1.5347E-07	72178.70c	2.2508E-07	
72179.70c	1.1238E-07	72180.70c	2.8944E-07			
c	Total	8.9160E-02				
mt134	h/zr.10t	zr/h.10t				
c						
c	----- Fuel Rod : 11786	-----			---	
m135	92234.70c	9.9720E-06	92235.70c	1.0889E-03	92236.70c	1.2085E-05
	92238.70c	4.3497E-03	5010.70c	7.6416E-08	5011.70c	3.0758E-07
	1001.70c	5.0638E-02	1002.70c	5.8241E-06	6000.70c	1.1521E-03
	40090.70c	1.6491E-02	40091.70c	3.5962E-03	40092.70c	5.4968E-03
	40094.70c	5.5706E-03	40096.70c	8.9744E-04	68162.70c	3.2577E-07
	68164.70c	3.7463E-06	68166.70c	7.8207E-05	68167.70c	5.3356E-05
	68168.70c	6.2314E-05	68170.70c	3.4741E-05	72174.70c	1.3210E-09
	72176.70c	4.3429E-08	72177.70c	1.5357E-07	72178.70c	2.2524E-07
	72179.70c	1.1245E-07	72180.70c	2.8964E-07		
c	Total	8.9542E-02				
mt135	h/zr.10t	zr/h.10t				
c						
c	----- Fuel Rod : 11787	-----				---
m136	92234.70c	9.8808E-06	92235.70c	1.0784E-03	92236.70c	1.1974E-05
	92238.70c	4.3104E-03	5010.70c	7.6121E-08	5011.70c	3.0640E-07
	1001.70c	5.0244E-02	1002.70c	5.7788E-06	6000.70c	1.0759E-03
	40090.70c	1.6467E-02	40091.70c	3.5909E-03	40092.70c	5.4888E-03
	40094.70c	5.5625E-03	40096.70c	8.9614E-04	68162.70c	3.3172E-07
	68164.70c	3.8147E-06	68166.70c	7.9636E-05	68167.70c	5.4331E-05
	68168.70c	6.3453E-05	68170.70c	3.5375E-05	72174.70c	1.3191E-09
	72176.70c	4.3366E-08	72177.70c	1.5335E-07	72178.70c	2.2491E-07
	72179.70c	1.1229E-07	72180.70c	2.8922E-07		
c	Total	8.8980E-02				
mt136	h/zr.10t	zr/h.10t				
c						
c	----- Fuel Rod : 11788	-----				---
m137	92234.70c	9.8831E-06	92235.70c	1.0787E-03	92236.70c	1.1977E-05
	92238.70c	4.3115E-03	5010.70c	7.6141E-08	5011.70c	3.0648E-07
	1001.70c	5.0573E-02	1002.70c	5.8166E-06	6000.70c	1.0762E-03
	40090.70c	1.6469E-02	40091.70c	3.5916E-03	40092.70c	5.4898E-03
	40094.70c	5.5634E-03	40096.70c	8.9630E-04	68162.70c	3.3181E-07
	68164.70c	3.8158E-06	68166.70c	7.9658E-05	68167.70c	5.4345E-05
	68168.70c	6.3470E-05	68170.70c	3.5385E-05	72174.70c	1.3194E-09
	72176.70c	4.3374E-08	72177.70c	1.5337E-07	72178.70c	2.2495E-07
	72179.70c	1.1231E-07	72180.70c	2.8927E-07		
c	Total	8.9316E-02				
mt137	h/zr.10t	zr/h.10t				
c						
c	----- Fuel Rod : 11789	-----				---
m138	92234.70c	9.9661E-06	92235.70c	1.0883E-03	92236.70c	1.2077E-05
	92238.70c	4.3471E-03	5010.70c	7.6369E-08	5011.70c	3.0740E-07
	1001.70c	5.0607E-02	1002.70c	5.8204E-06	6000.70c	1.1514E-03
	40090.70c	1.6480E-02	40091.70c	3.5940E-03	40092.70c	5.4934E-03
	40094.70c	5.5671E-03	40096.70c	8.9689E-04	68162.70c	3.2557E-07
	68164.70c	3.7440E-06	68166.70c	7.8159E-05	68167.70c	5.3323E-05
	68168.70c	6.2276E-05	68170.70c	3.4719E-05	72174.70c	1.3202E-09
	72176.70c	4.3402E-08	72177.70c	1.5348E-07	72178.70c	2.2510E-07
	72179.70c	1.1238E-07	72180.70c	2.8946E-07		
c	Total	8.9487E-02				
mt138	h/zr.10t	zr/h.10t				
c						
c	----- Fuel Rod : 11790	-----				---
m139	92234.70c	9.9310E-06	92235.70c	1.0855E-03	92236.70c	1.2035E-05
	92238.70c	4.3307E-03	5010.70c	7.6397E-08	5011.70c	3.0751E-07
	1001.70c	5.0733E-02	1002.70c	5.8350E-06	6000.70c	1.0798E-03
	40090.70c	1.6521E-02	40091.70c	3.6029E-03	40092.70c	5.5071E-03
	40094.70c	5.5810E-03	40096.70c	8.9912E-04	68162.70c	3.2207E-07
	68164.70c	3.7038E-06	68166.70c	7.7319E-05	68167.70c	5.2750E-05
	68168.70c	6.1607E-05	68170.70c	3.4346E-05	72174.70c	1.3235E-09
	72176.70c	4.3510E-08	72177.70c	1.5386E-07	72178.70c	2.2566E-07
	72179.70c	1.1266E-07	72180.70c	2.9018E-07		
c	Total	8.9600E-02				
mt139	h/zr.10t	zr/h.10t				
c						
c	----- Fuel Rod : 11791	-----				---

Fundamental - FUND

NRAD-FUND-RESR-001
CRIT-REAC-COEF

m140 92234.70c 9.8835E-06 92235.70c 1.0787E-03 92236.70c 1.1977E-05
 92238.70c 4.3117E-03 5010.70c 7.6144E-08 5011.70c 3.0649E-07
 1001.70c 5.0260E-02 1002.70c 5.7806E-06 6000.70c 1.0763E-03
 40090.70c 1.6472E-02 40091.70c 3.5921E-03 40092.70c 5.4905E-03
 40094.70c 5.5642E-03 40096.70c 8.9641E-04 68162.70c 3.3182E-07
 68164.70c 3.8159E-06 68166.70c 7.9660E-05 68167.70c 5.4347E-05
 68168.70c 6.3472E-05 68170.70c 3.5386E-05 72174.70c 1.3195E-09
 72176.70c 4.3379E-08 72177.70c 1.5339E-07 72178.70c 2.2498E-07
 72179.70c 1.1232E-07 72180.70c 2.8931E-07

c Total 8.9007E-02

mt140 h/zr.10t zr/h.10t

c

c ----- Fuel Rod : 11792 -----

m141 92234.70c 9.8794E-06 92235.70c 1.0783E-03 92236.70c 1.1972E-05
 92238.70c 4.3099E-03 5010.70c 7.6115E-08 5011.70c 3.0637E-07
 1001.70c 5.0242E-02 1002.70c 5.7784E-06 6000.70c 1.0759E-03
 40090.70c 1.6466E-02 40091.70c 3.5907E-03 40092.70c 5.4885E-03
 40094.70c 5.5621E-03 40096.70c 8.9609E-04 68162.70c 3.3169E-07
 68164.70c 3.8144E-06 68166.70c 7.9629E-05 68167.70c 5.4326E-05
 68168.70c 6.3448E-05 68170.70c 3.5372E-05 72174.70c 1.3190E-09
 72176.70c 4.3364E-08 72177.70c 1.5334E-07 72178.70c 2.2490E-07
 72179.70c 1.1228E-07 72180.70c 2.8920E-07

c Total 8.8974E-02

mt141 h/zr.10t zr/h.10t

c

c ----- Fuel Rod : 11793 -----

m142 92234.70c 9.8835E-06 92235.70c 1.0787E-03 92236.70c 1.1977E-05
 92238.70c 4.3117E-03 5010.70c 7.6141E-08 5011.70c 3.0648E-07
 1001.70c 5.0573E-02 1002.70c 5.8165E-06 6000.70c 1.0762E-03
 40090.70c 1.6469E-02 40091.70c 3.5915E-03 40092.70c 5.4897E-03
 40094.70c 5.5633E-03 40096.70c 8.9628E-04 68162.70c 3.3181E-07
 68164.70c 3.8158E-06 68166.70c 7.9658E-05 68167.70c 5.4345E-05
 68168.70c 6.3470E-05 68170.70c 3.5385E-05 72174.70c 1.3193E-09
 72176.70c 4.3373E-08 72177.70c 1.5337E-07 72178.70c 2.2495E-07
 72179.70c 1.1231E-07 72180.70c 2.8926E-07

c Total 8.9315E-02

mt142 h/zr.10t zr/h.10t

c

c ----- Fuel Rod : 11794 -----

m143 92234.70c 9.9205E-06 92235.70c 1.0844E-03 92236.70c 1.2022E-05
 92238.70c 4.3262E-03 5010.70c 7.6317E-08 5011.70c 3.0719E-07
 1001.70c 5.0365E-02 1002.70c 5.7926E-06 6000.70c 1.0787E-03
 40090.70c 1.6506E-02 40091.70c 3.5995E-03 40092.70c 5.5020E-03
 40094.70c 5.5757E-03 40096.70c 8.9828E-04 68162.70c 3.2173E-07
 68164.70c 3.6999E-06 68166.70c 7.7238E-05 68167.70c 5.2694E-05
 68168.70c 6.1542E-05 68170.70c 3.4310E-05 72174.70c 1.3223E-09
 72176.70c 4.3470E-08 72177.70c 1.5371E-07 72178.70c 2.2545E-07
 72179.70c 1.1256E-07 72180.70c 2.8991E-07

c Total 8.9194E-02

mt143 h/zr.10t zr/h.10t

c

c ----- Fuel Rod : 11795 -----

m144 92234.70c 9.9464E-06 92235.70c 1.0870E-03 92236.70c 1.2054E-05
 92238.70c 4.3377E-03 5010.70c 7.6389E-08 5011.70c 3.0748E-07
 1001.70c 5.0684E-02 1002.70c 5.8293E-06 6000.70c 1.0797E-03
 40090.70c 1.6505E-02 40091.70c 3.5994E-03 40092.70c 5.5018E-03
 40094.70c 5.5756E-03 40096.70c 8.9825E-04 68162.70c 3.2565E-07
 68164.70c 3.7450E-06 68166.70c 7.8179E-05 68167.70c 5.3337E-05
 68168.70c 6.2292E-05 68170.70c 3.4728E-05 72174.70c 1.3222E-09
 72176.70c 4.3468E-08 72177.70c 1.5371E-07 72178.70c 2.2544E-07
 72179.70c 1.1255E-07 72180.70c 2.8990E-07

c Total 8.9530E-02

mt144 h/zr.10t zr/h.10t

c

c ----- Fuel Rod : 11796 -----

m145 92234.70c 9.9423E-06 92235.70c 1.0866E-03 92236.70c 1.2049E-05
 92238.70c 4.3359E-03 5010.70c 7.6357E-08 5011.70c 3.0735E-07
 1001.70c 5.0977E-02 1002.70c 5.8631E-06 6000.70c 1.0793E-03
 40090.70c 1.6497E-02 40091.70c 3.5975E-03 40092.70c 5.4989E-03
 40094.70c 5.5726E-03 40096.70c 8.9777E-04 68162.70c 3.2551E-07
 68164.70c 3.7434E-06 68166.70c 7.8147E-05 68167.70c 5.3315E-05
 68168.70c 6.2266E-05 68170.70c 3.4714E-05 72174.70c 1.3215E-09
 72176.70c 4.3445E-08 72177.70c 1.5363E-07 72178.70c 2.2532E-07
 72179.70c 1.1250E-07 72180.70c 2.8975E-07

c Total 8.9804E-02

mt145 h/zr.10t zr/h.10t

Fundamental - FUND

NRAD-FUND-RESR-001
CRIT-REAC-COEF

```

c
c ----- Fuel Rod : 11797 -----
m146 92234.70c 9.9512E-06 92235.70c 1.0876E-03 92236.70c 1.2059E-05
      92238.70c 4.3397E-03 5010.70c 7.6427E-08 5011.70c 3.0763E-07
      1001.70c 5.0709E-02 1002.70c 5.8322E-06 6000.70c 1.0803E-03
      40090.70c 1.6514E-02 40091.70c 3.6012E-03 40092.70c 5.5045E-03
      40094.70c 5.5783E-03 40096.70c 8.9869E-04 68162.70c 3.2581E-07
      68164.70c 3.7468E-06 68166.70c 7.8218E-05 68167.70c 5.3363E-05
      68168.70c 6.2323E-05 68170.70c 3.4745E-05 72174.70c 1.3229E-09
      72176.70c 4.3490E-08 72177.70c 1.5379E-07 72178.70c 2.2555E-07
      72179.70c 1.1261E-07 72180.70c 2.9004E-07
c      Total 8.9574E-02
mt146 h/zr.10t zr/h.10t
c
c ----- Fuel Rod : 11798 -----
m147 92234.70c 9.9348E-06 92235.70c 1.0858E-03 92236.70c 1.2039E-05
      92238.70c 4.3326E-03 5010.70c 7.6299E-08 5011.70c 3.0711E-07
      1001.70c 5.0946E-02 1002.70c 5.8595E-06 6000.70c 1.0066E-03
      40090.70c 1.6487E-02 40091.70c 3.5953E-03 40092.70c 5.4955E-03
      40094.70c 5.5692E-03 40096.70c 8.9723E-04 68162.70c 3.2888E-07
      68164.70c 3.7821E-06 68166.70c 7.8955E-05 68167.70c 5.3866E-05
      68168.70c 6.2910E-05 68170.70c 3.5073E-05 72174.70c 1.3207E-09
      72176.70c 4.3419E-08 72177.70c 1.5353E-07 72178.70c 2.2518E-07
      72179.70c 1.1243E-07 72180.70c 2.8957E-07
c      Total 8.9679E-02
mt147 h/zr.10t zr/h.10t
c
c ----- Fuel Rod : 11799 -----
m148 92234.70c 9.8641E-06 92235.70c 1.0765E-03 92236.70c 1.1954E-05
      92238.70c 4.3032E-03 5010.70c 7.5993E-08 5011.70c 3.0588E-07
      1001.70c 5.0788E-02 1002.70c 5.8413E-06 6000.70c 1.0741E-03
      40090.70c 1.6435E-02 40091.70c 3.5841E-03 40092.70c 5.4784E-03
      40094.70c 5.5519E-03 40096.70c 8.9444E-04 68162.70c 3.3116E-07
      68164.70c 3.8083E-06 68166.70c 7.9502E-05 68167.70c 5.4239E-05
      68168.70c 6.3346E-05 68170.70c 3.5316E-05 72174.70c 1.3166E-09
      72176.70c 4.3284E-08 72177.70c 1.5306E-07 72178.70c 2.2448E-07
      72179.70c 1.1208E-07 72180.70c 2.8867E-07
c      Total 8.9451E-02
mt148 h/zr.10t zr/h.10t
c
c ----- Fuel Rod : 11800 -----
m149 92234.70c 1.0019E-05 92235.70c 1.0934E-03 92236.70c 1.2141E-05
      92238.70c 4.3707E-03 5010.70c 7.6345E-08 5011.70c 3.0730E-07
      1001.70c 5.0490E-02 1002.70c 5.8070E-06 6000.70c 1.0431E-03
      40090.70c 1.6442E-02 40091.70c 3.5856E-03 40092.70c 5.4807E-03
      40094.70c 5.5542E-03 40096.70c 8.9481E-04 68162.70c 3.2546E-07
      68164.70c 3.7428E-06 68166.70c 7.8134E-05 68167.70c 5.3306E-05
      68168.70c 6.2257E-05 68170.70c 3.4708E-05 72174.70c 1.3172E-09
      72176.70c 4.3302E-08 72177.70c 1.5312E-07 72178.70c 2.2458E-07
      72179.70c 1.1212E-07 72180.70c 2.8879E-07
c      Total 8.9216E-02
mt149 h/zr.10t zr/h.10t
c
c ----- Fuel Rod : 11801 -----
m150 92234.70c 9.9357E-06 92235.70c 1.0864E-03 92236.70c 1.2041E-05
      92238.70c 4.3325E-03 5010.70c 7.6306E-08 5011.70c 3.0714E-07
      1001.70c 5.0651E-02 1002.70c 5.8255E-06 6000.70c 9.7070E-04
      40090.70c 1.6495E-02 40091.70c 3.5971E-03 40092.70c 5.4982E-03
      40094.70c 5.5719E-03 40096.70c 8.9767E-04 68162.70c 3.2530E-07
      68164.70c 3.7409E-06 68166.70c 7.8095E-05 68167.70c 5.3279E-05
      68168.70c 6.2225E-05 68170.70c 3.4691E-05 72174.70c 1.3214E-09
      72176.70c 4.3440E-08 72177.70c 1.5361E-07 72178.70c 2.2529E-07
      72179.70c 1.1248E-07 72180.70c 2.8971E-07
c      Total 8.9361E-02
mt150 h/zr.10t zr/h.10t
c
c ----- Fuel Rod : 11802 -----
m151 92234.70c 1.0000E-05 92235.70c 1.0942E-03 92236.70c 1.2119E-05
      92238.70c 4.3598E-03 5010.70c 7.6333E-08 5011.70c 3.0725E-07
      1001.70c 5.0204E-02 1002.70c 5.7742E-06 6000.70c 9.3508E-04
      40090.70c 1.6453E-02 40091.70c 3.5881E-03 40092.70c 5.4845E-03
      40094.70c 5.5580E-03 40096.70c 8.9542E-04 68162.70c 3.3626E-07
      68164.70c 3.8670E-06 68166.70c 8.0726E-05 68167.70c 5.5074E-05
      68168.70c 6.4321E-05 68170.70c 3.5859E-05 72174.70c 1.3181E-09
      72176.70c 4.3332E-08 72177.70c 1.5323E-07 72178.70c 2.2473E-07
      72179.70c 1.1220E-07 72180.70c 2.8899E-07

```

Fundamental - FUND

NRAD-FUND-RESR-001
CRIT-REAC-COEF

```

c          Total 8.8842E-02
mt151  h/zr.10t  zr/h.10t
c
c ----- Fuel Rod : 11803 -----
m152  92234.70c 9.9943E-06  92235.70c 1.0936E-03  92236.70c 1.2111E-05  ---
      92238.70c 4.3572E-03   5010.70c 7.6288E-08   5011.70c 3.0707E-07
      1001.70c 5.0489E-02   1002.70c 5.8069E-06   6000.70c 9.3453E-04
      40090.70c 1.6442E-02  40091.70c 3.5856E-03  40092.70c 5.4807E-03
      40094.70c 5.5542E-03  40096.70c 8.9480E-04  68162.70c 3.3606E-07
      68164.70c 3.8647E-06  68166.70c 8.0678E-05  68167.70c 5.5042E-05
      68168.70c 6.4284E-05  68170.70c 3.5838E-05  72174.70c 1.3172E-09
      72176.70c 4.3301E-08  72177.70c 1.5312E-07  72178.70c 2.2457E-07
      72179.70c 1.1212E-07  72180.70c 2.8879E-07
c          Total 8.9101E-02
mt152  h/zr.10t  zr/h.10t
c
c ----- Fuel Rod : 11804 -----
m153  92234.70c 9.9156E-06  92235.70c 1.0824E-03  92236.70c 1.2016E-05  ---
      92238.70c 4.3255E-03   5010.70c 7.6236E-08   5011.70c 3.0686E-07
      1001.70c 5.0314E-02   1002.70c 5.7867E-06   6000.70c 9.6981E-04
      40090.70c 1.6489E-02  40091.70c 3.5959E-03  40092.70c 5.4964E-03
      40094.70c 5.5701E-03  40096.70c 8.9737E-04  68162.70c 3.2500E-07
      68164.70c 3.7375E-06  68166.70c 7.8023E-05  68167.70c 5.3230E-05
      68168.70c 6.2168E-05  68170.70c 3.4659E-05  72174.70c 1.3209E-09
      72176.70c 4.3426E-08  72177.70c 1.5356E-07  72178.70c 2.2522E-07
      72179.70c 1.1244E-07  72180.70c 2.8962E-07
c          Total 8.9001E-02
mt153  h/zr.10t  zr/h.10t
c
c ----- Fuel Rod : 11805 -----
m154  92234.70c 9.9329E-06  92235.70c 1.0843E-03  92236.70c 1.2037E-05  ---
      92238.70c 4.3330E-03   5010.70c 7.6371E-08   5011.70c 3.0740E-07
      1001.70c 5.0718E-02   1002.70c 5.8332E-06   6000.70c 9.7152E-04
      40090.70c 1.6517E-02  40091.70c 3.6019E-03  40092.70c 5.5055E-03
      40094.70c 5.5793E-03  40096.70c 8.9886E-04  68162.70c 3.2557E-07
      68164.70c 3.7441E-06  68166.70c 7.8160E-05  68167.70c 5.3324E-05
      68168.70c 6.2277E-05  68170.70c 3.4720E-05  72174.70c 1.3231E-09
      72176.70c 4.3498E-08  72177.70c 1.5381E-07  72178.70c 2.2559E-07
      72179.70c 1.1263E-07  72180.70c 2.9010E-07
c          Total 8.9470E-02
mt154  h/zr.10t  zr/h.10t
c
c ----- Fuel Rod : 11806 -----
m155  92234.70c 9.9639E-06  92235.70c 1.0883E-03  92236.70c 1.2075E-05  ---
      92238.70c 4.3460E-03   5010.70c 7.6352E-08   5011.70c 3.0733E-07
      1001.70c 5.0603E-02   1002.70c 5.8200E-06   6000.70c 1.0792E-03
      40090.70c 1.6479E-02  40091.70c 3.5937E-03  40092.70c 5.4930E-03
      40094.70c 5.5666E-03  40096.70c 8.9681E-04  68162.70c 3.2911E-07
      68164.70c 3.7848E-06  68166.70c 7.9010E-05  68167.70c 5.3904E-05
      68168.70c 6.2954E-05  68170.70c 3.5097E-05  72174.70c 1.3201E-09
      72176.70c 4.3399E-08  72177.70c 1.5346E-07  72178.70c 2.2508E-07
      72179.70c 1.1237E-07  72180.70c 2.8943E-07
c          Total 8.9409E-02
mt155  h/zr.10t  zr/h.10t
c
c ----- Fuel Rod : 11807 -----
m156  92234.70c 9.9780E-06  92235.70c 1.0898E-03  92236.70c 1.2092E-05  ---
      92238.70c 4.3521E-03   5010.70c 7.6459E-08   5011.70c 3.0776E-07
      1001.70c 5.0673E-02   1002.70c 5.8281E-06   6000.70c 1.0807E-03
      40090.70c 1.6502E-02  40091.70c 3.5987E-03  40092.70c 5.5007E-03
      40094.70c 5.5744E-03  40096.70c 8.9807E-04  68162.70c 3.2957E-07
      68164.70c 3.7901E-06  68166.70c 7.9121E-05  68167.70c 5.3979E-05
      68168.70c 6.3042E-05  68170.70c 3.5146E-05  72174.70c 1.3220E-09
      72176.70c 4.3460E-08  72177.70c 1.5368E-07  72178.70c 2.2539E-07
      72179.70c 1.1253E-07  72180.70c 2.8984E-07
c          Total 8.9534E-02
mt156  h/zr.10t  zr/h.10t
c
c ----- Fuel Rod : 11808 -----
m157  92234.70c 9.9111E-06  92235.70c 1.0833E-03  92236.70c 1.2011E-05  ---
      92238.70c 4.3221E-03   5010.70c 7.6201E-08   5011.70c 3.0672E-07
      1001.70c 5.0561E-02   1002.70c 5.8152E-06   6000.70c 1.1130E-03
      40090.70c 1.6465E-02  40091.70c 3.5907E-03  40092.70c 5.4885E-03
      40094.70c 5.5621E-03  40096.70c 8.9607E-04  68162.70c 3.3207E-07
      68164.70c 3.8188E-06  68166.70c 7.9720E-05  68167.70c 5.4388E-05
      68168.70c 6.3520E-05  68170.70c 3.5413E-05  72174.70c 1.3190E-09

```

Fundamental - FUND

NRAD-FUND-RESR-001
CRIT-REAC-COEF

	72176.70c	4.3363E-08	72177.70c	1.5334E-07	72178.70c	2.2489E-07	
	72179.70c	1.1228E-07	72180.70c	2.8920E-07			
c	Total 8.9348E-02						
mt157	h/zr.10t	zr/h.10t					
c	----- Fuel Rod : 11809 -----						---
m158	92234.70c	9.9292E-06	92235.70c	1.0853E-03	92236.70c	1.2033E-05	
	92238.70c	4.3300E-03	5010.70c	7.6339E-08	5011.70c	3.0727E-07	
	1001.70c	5.0967E-02	1002.70c	5.8618E-06	6000.70c	1.1150E-03	
	40090.70c	1.6493E-02	40091.70c	3.5968E-03	40092.70c	5.4977E-03	
	40094.70c	5.5714E-03	40096.70c	8.9758E-04	68162.70c	3.3267E-07	
	68164.70c	3.8257E-06	68166.70c	7.9864E-05	68167.70c	5.4486E-05	
	68168.70c	6.3634E-05	68170.70c	3.5477E-05	72174.70c	1.3213E-09	
	72176.70c	4.3436E-08	72177.70c	1.5360E-07	72178.70c	2.2527E-07	
	72179.70c	1.1247E-07	72180.70c	2.8968E-07			
c	Total 8.9820E-02						
mt158	h/zr.10t	zr/h.10t					
c	----- Fuel Rod : 11810 -----						---
m159	92234.70c	1.0034E-05	92235.70c	1.0957E-03	92236.70c	1.2159E-05	
	92238.70c	4.3766E-03	5010.70c	7.6462E-08	5011.70c	3.0777E-07	
	1001.70c	5.0852E-02	1002.70c	5.8487E-06	6000.70c	1.0447E-03	
	40090.70c	1.6456E-02	40091.70c	3.5887E-03	40092.70c	5.4854E-03	
	40094.70c	5.5589E-03	40096.70c	8.9557E-04	68162.70c	3.4045E-07	
	68164.70c	3.9151E-06	68166.70c	8.1732E-05	68167.70c	5.5760E-05	
	68168.70c	6.5123E-05	68170.70c	3.6306E-05	72174.70c	1.3183E-09	
	72176.70c	4.3339E-08	72177.70c	1.5325E-07	72178.70c	2.2477E-07	
	72179.70c	1.1222E-07	72180.70c	2.8903E-07			
c	Total 8.9626E-02						
mt159	h/zr.10t	zr/h.10t					
c	----- Fuel Rod : 11811 -----						---
m160	92234.70c	9.9882E-06	92235.70c	1.0901E-03	92236.70c	1.2104E-05	
	92238.70c	4.3574E-03	5010.70c	7.6370E-08	5011.70c	3.0740E-07	
	1001.70c	5.1524E-02	1002.70c	5.9260E-06	6000.70c	9.3553E-04	
	40090.70c	1.6466E-02	40091.70c	3.5909E-03	40092.70c	5.4888E-03	
	40094.70c	5.5624E-03	40096.70c	8.9613E-04	68162.70c	3.3642E-07	
	68164.70c	3.8689E-06	68166.70c	8.0765E-05	68167.70c	5.5101E-05	
	68168.70c	6.4353E-05	68170.70c	3.5877E-05	72174.70c	1.3191E-09	
	72176.70c	4.3366E-08	72177.70c	1.5335E-07	72178.70c	2.2491E-07	
	72179.70c	1.1229E-07	72180.70c	2.8922E-07			
c	Total 9.0182E-02						
mt160	h/zr.10t	zr/h.10t					
c	----- Fuel Rod : 11812 -----						---
m161	92234.70c	9.9504E-06	92235.70c	1.0871E-03	92236.70c	1.2058E-05	
	92238.70c	4.3398E-03	5010.70c	7.6331E-08	5011.70c	3.0724E-07	
	1001.70c	5.0261E-02	1002.70c	5.7807E-06	6000.70c	1.1508E-03	
	40090.70c	1.6472E-02	40091.70c	3.5921E-03	40092.70c	5.4907E-03	
	40094.70c	5.5643E-03	40096.70c	8.9643E-04	68162.70c	3.3987E-07	
	68164.70c	3.9085E-06	68166.70c	8.1592E-05	68167.70c	5.5665E-05	
	68168.70c	6.5012E-05	68170.70c	3.6244E-05	72174.70c	1.3196E-09	
	72176.70c	4.3380E-08	72177.70c	1.5340E-07	72178.70c	2.2498E-07	
	72179.70c	1.1233E-07	72180.70c	2.8931E-07			
c	Total 8.9126E-02						
mt161	h/zr.10t	zr/h.10t					
c	----- Fuel Rod : 11813 -----						---
m162	92234.70c	9.9525E-06	92235.70c	1.0889E-03	92236.70c	1.2061E-05	
	92238.70c	4.3392E-03	5010.70c	7.6392E-08	5011.70c	3.0749E-07	
	1001.70c	5.0321E-02	1002.70c	5.7876E-06	6000.70c	1.1158E-03	
	40090.70c	1.6492E-02	40091.70c	3.5964E-03	40092.70c	5.4972E-03	
	40094.70c	5.5710E-03	40096.70c	8.9751E-04	68162.70c	3.4014E-07	
	68164.70c	3.9116E-06	68166.70c	8.1657E-05	68167.70c	5.5710E-05	
	68168.70c	6.5063E-05	68170.70c	3.6273E-05	72174.70c	1.3211E-09	
	72176.70c	4.3432E-08	72177.70c	1.5358E-07	72178.70c	2.2525E-07	
	72179.70c	1.1246E-07	72180.70c	2.8966E-07			
c	Total 8.9191E-02						
mt162	h/zr.10t	zr/h.10t					
c	----- Fuel Rod : 11814 -----						---
m163	92234.70c	1.0073E-05	92235.70c	1.1029E-03	92236.70c	1.2207E-05	
	92238.70c	4.3911E-03	5010.70c	7.6537E-08	5011.70c	3.0807E-07	
	1001.70c	5.0199E-02	1002.70c	5.7736E-06	6000.70c	1.0818E-03	
	40090.70c	1.6452E-02	40091.70c	3.5877E-03	40092.70c	5.4839E-03	
	40094.70c	5.5575E-03	40096.70c	8.9533E-04	68162.70c	3.4078E-07	

Fundamental - FUND

NRAD-FUND-RESR-001
CRIT-REAC-COEF

```

68164.70c 3.9190E-06 68166.70c 8.1812E-05 68167.70c 5.5815E-05
68168.70c 6.5187E-05 68170.70c 3.6342E-05 72174.70c 1.3179E-09
72176.70c 4.3327E-08 72177.70c 1.5321E-07 72178.70c 2.2471E-07
72179.70c 1.1219E-07 72180.70c 2.8896E-07
c      Total 8.9024E-02
mt163  h/zr.10t zr/h.10t
c
c ----- Fuel Rod : 11815 -----
m164  92234.70c 1.0034E-05 92235.70c 1.1001E-03 92236.70c 1.2160E-05
92238.70c 4.3725E-03 5010.70c 7.6442E-08 5011.70c 3.0769E-07
1001.70c 5.0240E-02 1002.70c 5.7783E-06 6000.70c 9.7243E-04
40090.70c 1.6465E-02 40091.70c 3.5906E-03 40092.70c 5.4883E-03
40094.70c 5.5620E-03 40096.70c 8.9606E-04 68162.70c 3.2950E-07
68164.70c 3.7892E-06 68166.70c 7.9103E-05 68167.70c 5.3967E-05
68168.70c 6.3028E-05 68170.70c 3.5138E-05 72174.70c 1.3190E-09
72176.70c 4.3362E-08 72177.70c 1.5333E-07 72178.70c 2.2489E-07
72179.70c 1.1228E-07 72180.70c 2.8919E-07
c      Total 8.8952E-02
mt164  h/zr.10t zr/h.10t
c
c --- Average UErZrH Fuel -----
c ----- 56-Rod-Average Fuel Rod Composition -----
m201  92234.70c 9.9283E-06 92235.70c 1.0836E-03 92236.70c 1.2032E-05
92238.70c 4.3312E-03 5010.70c 7.6273E-08 5011.70c 3.0701E-07
1001.70c 5.0614E-02 1002.70c 5.8213E-06 6000.70c 1.0781E-03
40090.70c 1.6483E-02 40091.70c 3.5945E-03 40092.70c 5.4942E-03
40094.70c 5.5679E-03 40096.70c 8.9701E-04 68162.70c 3.2516E-07
68164.70c 3.7393E-06 68166.70c 7.8061E-05 68167.70c 5.3256E-05
68168.70c 6.2198E-05 68170.70c 3.4676E-05 72174.70c 1.3204E-09
72176.70c 4.3408E-08 72177.70c 1.5350E-07 72178.70c 2.2513E-07
72179.70c 1.1240E-07 72180.70c 2.8950E-07
c      Total 8.9404E-02
mt201  h/zr.10t zr/h.10t
c
c ----- 60-Rod-Average Fuel Rod Composition -----
m202  92234.70c 9.9323E-06 92235.70c 1.0844E-03 92236.70c 1.2036E-05
92238.70c 4.3326E-03 5010.70c 7.6277E-08 5011.70c 3.0702E-07
1001.70c 5.0608E-02 1002.70c 5.8206E-06 6000.70c 1.0781E-03
40090.70c 1.6481E-02 40091.70c 3.5940E-03 40092.70c 5.4936E-03
40094.70c 5.5672E-03 40096.70c 8.9691E-04 68162.70c 3.2517E-07
68164.70c 3.7395E-06 68166.70c 7.8064E-05 68167.70c 5.3258E-05
68168.70c 6.2200E-05 68170.70c 3.4677E-05 72174.70c 1.3203E-09
72176.70c 4.3403E-08 72177.70c 1.5348E-07 72178.70c 2.2510E-07
72179.70c 1.1239E-07 72180.70c 2.8947E-07
c      Total 8.9397E-02
mt202  h/zr.10t zr/h.10t
c
c ----- 64-Rod-Average Fuel Rod Composition -----
m203  92234.70c 9.9363E-06 92235.70c 1.0851E-03 92236.70c 1.2041E-05
92238.70c 4.3340E-03 5010.70c 7.6286E-08 5011.70c 3.0706E-07
1001.70c 5.0608E-02 1002.70c 5.8206E-06 6000.70c 1.0783E-03
40090.70c 1.6481E-02 40091.70c 3.5940E-03 40092.70c 5.4935E-03
40094.70c 5.5672E-03 40096.70c 8.9690E-04 68162.70c 3.2521E-07
68164.70c 3.7399E-06 68166.70c 7.8073E-05 68167.70c 5.3265E-05
68168.70c 6.2208E-05 68170.70c 3.4681E-05 72174.70c 1.3202E-09
72176.70c 4.3403E-08 72177.70c 1.5348E-07 72178.70c 2.2510E-07
72179.70c 1.1239E-07 72180.70c 2.8946E-07
c      Total 8.9399E-02
mt203  h/zr.10t zr/h.10t
c
c
c *** Control Cards *****
mode n
kcode 100000 1 50 1550
ksrc -1.9431 -1.9431 96.6 1.9431 1.9431 96.6
-5.8293 5.8293 96.6 5.8293 -5.8293 96.6
-9.7155 -9.7155 96.6 9.7155 9.7155 96.6
-13.6017 13.6017 96.6 13.6017 -13.6017 96.6
-13.6017 0.0 96.6 13.6017 0.0 96.6
0.0 13.6017 96.6 0.0 -13.6017 96.6
print
kopts blocksize=10 kinetics=yes precursor=yes
c

```

APPENDIX D: AS-BUILT FUEL DATA

A summary of the as-built fuel data obtained from the shipping documentation for the NRAD fuel elements is provided in this appendix. Table D.1 contains data specific to the uranium content of the fuel. Table D.2 contains a summary of additional fuel measurements.

Table D.1. As-Built Fuel Data (Uranium Content).

Element Number	Total Mass (g)	Uranium Mass (g)	²³⁵U Mass (g)	²³⁵U Enrichment (%)	Uranium Content (wt.%)
11752	2503.57	747.73	147.68	19.75	29.87
11753	2504.51	750.94	148.29	19.75	29.98
11754	2505.34	751.19	148.33	19.75	29.98
11755	2503.53	750.64	148.23	19.75	29.98
11756	2504.75	751.01	148.29	19.75	29.98
11757	2503.62	750.67	148.23	19.75	29.98
11758	2504.35	750.89	148.28	19.75	29.98
11759	2503.18	750.54	148.21	19.75	29.98
11760	2508.34	751.67	148.42	19.75	29.97
11761	2506.59	749.05	147.76	19.73	29.88
11762	2510.22	750.14	147.88	19.71	29.88
11763	2511.18	750.42	147.93	19.71	29.88
11764	2509.55	749.94	147.84	19.71	29.88
11765	2508.80	749.72	147.79	19.71	29.88
11766	2510.72	750.29	147.90	19.71	29.88
11767	2508.16	749.52	147.76	19.71	29.88
11768	2504.76	748.92	147.84	19.74	29.90
11769	2500.76	747.73	147.60	19.74	29.90
11770	2506.39	749.40	147.94	19.74	29.90
11771	2502.98	748.40	147.73	19.74	29.90
11772	2506.50	749.45	147.94	19.74	29.90
11773	2504.00	748.71	147.80	19.74	29.90
11774	2505.26	749.07	147.87	19.74	29.90
11775	2502.48	747.41	147.52	19.74	29.87
11776	2511.48	749.28	147.76	19.72	29.83
11777	2503.32	743.92	146.75	19.73	29.72
11778	2507.07	749.21	147.75	19.72	29.88
11779	2502.48	743.66	146.70	19.73	29.72
11780	2506.19	748.93	147.69	19.72	29.88
11781	2502.51	746.33	147.26	19.73	29.82
11782	2506.61	751.14	148.20	19.73	29.97
11783	2506.90	751.23	148.21	19.73	29.97
11784	2509.46	752.01	148.37	19.73	29.97
11785	2509.11	752.32	148.51	19.74	29.98
11786	2511.09	752.90	148.62	19.74	29.98
11787	2501.38	746.01	147.19	19.73	29.82
11788	2502.06	746.19	147.22	19.73	29.82
11789	2509.55	752.45	148.54	19.74	29.98
11790	2510.46	749.80	148.16	19.76	29.87
11791	2502.13	746.22	147.23	19.73	29.82
11792	2501.18	745.91	147.17	19.73	29.82
11793	2502.06	746.22	147.23	19.73	29.82
11794	2507.83	749.01	148.00	19.76	29.87

Table D.1 (cont'd.). As-Built Fuel Data (Uranium Content).

Element Number	Total Mass (g)	Uranium Mass (g)	²³⁵ U Mass (g)	²³⁵ U Enrichment (%)	Uranium Content (wt.%)
11795	2510.20	750.97	148.36	19.76	29.92
11796	2509.15	750.66	148.30	19.76	29.92
11797	2511.43	751.33	148.44	19.76	29.92
11798	2507.25	750.09	148.19	19.76	29.92
11799	2497.17	744.75	146.93	19.73	29.82
11800	2508.76	756.42	149.23	19.73	30.15
11801	2507.48	750.16	148.28	19.77	29.92
11802	2508.35	755.02	149.34	19.78	30.10
11803	2506.88	754.58	149.26	19.78	30.10
11804	2505.18	748.64	147.73	19.73	29.88
11805	2509.59	749.95	147.99	19.73	29.88
11806	2508.99	752.29	148.53	19.74	29.98
11807	2512.51	753.35	148.74	19.74	29.98
11808	2504.02	748.30	147.86	19.76	29.88
11809	2508.54	749.67	148.13	19.76	29.88
11810	2512.59	757.55	149.54	19.74	30.15
11811	2509.58	754.12	148.78	19.73	30.05
11812	2508.30	751.27	148.37	19.75	29.95
11813	2510.30	751.43	148.62	19.78	29.93
11814	2515.05	760.56	150.53	19.79	30.24
11815	2511.94	757.60	150.15	19.82	30.16
Average (56 Rods) ^(a)	2506.4	749.6	147.9	19.74	29.91
±1σ ^(b) (56 Rods) ^(a)	3.5	2.5	0.5	0.01	0.07
Average (60 Rods) ^(c)	2506.5	749.9	148.0	19.74	29.92
±1σ ^(b) (60 Rods) ^(c)	3.4	2.7	0.6	0.02	0.09
Average (64 Rods)	2506.8	750.2	148.1	19.74	29.93
±1σ ^(b) (64 Rods)	3.6	3.1	0.7	0.02	0.10

(a) Fifty-six elements are in the initial core critical. Excluded elements include 11800, -801, -802, -803, -812, -813, -814, and -815.

(b) The uncertainty in these values is 1σ of the average population and not the average mean.

(c) Sixty elements are in the fully loaded core critical. Excluded elements include -812, -813, -814, and -815.

Table D.2. As-Built Fuel Data (Additional Measurements).

Element Number	H/Zr Ratio	Er Content (wt.%)	C Content (wt.%)	Fuel Length (mm)	Fuel Diameter (mm)	Cladding ID (mm)	Fuel-Clad Difference (mm)
11752	1.58	0.86	0.31	380.4	34.800	34.89	0.090
11753	1.58	0.86	0.31	380.0	34.800	34.89	0.090
11754	1.58	0.86	0.31	380.1	34.800	34.89	0.090
11755	1.59	0.86	0.31	379.8	34.800	34.89	0.090
11756	1.58	0.86	0.31	380.1	34.800	34.89	0.090
11757	1.58	0.86	0.31	380.2	34.800	34.90	0.100
11758	1.59	0.86	0.31	379.9	34.800	34.89	0.090
11759	1.60	0.86	0.31	379.7	34.800	34.89	0.090
11760	1.57	0.91	0.33	380.0	34.800	34.89	0.090
11761	1.57	0.90	0.31	379.2	34.803	34.89	0.087
11762	1.57	0.90	0.29	380.0	34.807	34.89	0.083
11763	1.58	0.90	0.29	379.6	34.807	34.89	0.083
11764	1.59	0.90	0.29	380.0	34.807	34.89	0.083
11765	1.59	0.90	0.29	379.8	34.807	34.89	0.083
11766	1.58	0.90	0.29	380.0	34.807	34.90	0.093
11767	1.57	0.90	0.29	379.6	34.803	34.89	0.087
11768	1.57	0.89	0.28	380.2	34.803	34.89	0.087
11769	1.57	0.89	0.29	379.9	34.803	34.89	0.087
11770	1.59	0.89	0.29	379.9	34.807	34.89	0.083
11771	1.58	0.89	0.29	379.8	34.803	34.89	0.087
11772	1.57	0.89	0.29	380.0	34.800	34.90	0.100
11773	1.58	0.89	0.29	379.8	34.803	34.90	0.097
11774	1.61	0.89	0.29	380.0	34.803	34.90	0.097
11775	1.58	0.91	0.29	380.1	34.807	34.90	0.093
11776	1.59	0.92	0.30	380.4	34.810	34.90	0.090
11777	1.58	0.90	0.30	380.8	34.807	34.90	0.093
11778	1.58	0.91	0.32	380.9	34.807	34.90	0.093
11779	1.58	0.90	0.30	381.0	34.803	34.89	0.087
11780	1.57	0.91	0.32	380.6	34.807	34.89	0.083
11781	1.58	0.92	0.30	380.5	34.807	34.89	0.083
11782	1.57	0.89	0.31	380.3	34.810	34.90	0.090
11783	1.57	0.89	0.31	380.5	34.810	34.89	0.080
11784	1.57	0.89	0.31	380.4	34.807	34.89	0.083
11785	1.57	0.90	0.32	380.6	34.810	34.89	0.080
11786	1.58	0.90	0.32	380.7	34.807	34.90	0.093
11787	1.57	0.92	0.30	380.5	34.810	34.89	0.080
11788	1.58	0.92	0.30	380.4	34.807	34.89	0.083
11789	1.58	0.90	0.32	380.7	34.803	34.89	0.087
11790	1.58	0.89	0.30	380.6	34.803	34.89	0.087
11791	1.57	0.92	0.30	380.5	34.803	34.89	0.087
11792	1.57	0.92	0.30	380.2	34.807	34.89	0.083
11793	1.58	0.92	0.30	380.4	34.807	34.90	0.093
11794	1.57	0.89	0.30	380.6	34.803	34.90	0.097

Table D.2 (cont'd.). As-Built Fuel Data (Additional Measurements).

Element Number	H/Zr Ratio	Er Content (wt.%)	C Content (wt.%)	Fuel Length (mm)	Fuel Diameter (mm)	Cladding ID (mm)	Fuel-Clad Difference (mm)
11795	1.58	0.90	0.30	380.7	34.810	34.89	0.080
11796	1.59	0.90	0.30	380.8	34.810	34.90	0.090
11797	1.58	0.90	0.30	380.9	34.807	34.90	0.093
11798	1.59	0.91	0.28	380.9	34.807	34.90	0.093
11799	1.59	0.92	0.30	380.1	34.803	34.89	0.087
11800	1.58	0.90	0.29	380.1	34.807	34.90	0.093
11801	1.58	0.90	0.27	380.2	34.803	34.89	0.087
11802	1.57	0.93	0.26	380.2	34.800	34.89	0.090
11803	1.58	0.93	0.26	380.1	34.800	34.90	0.100
11804	1.57	0.90	0.27	380.0	34.810	34.90	0.090
11805	1.58	0.90	0.27	380.3	34.810	34.90	0.090
11806	1.58	0.91	0.30	380.5	34.807	34.90	0.093
11807	1.58	0.91	0.30	380.8	34.810	34.90	0.090
11808	1.58	0.92	0.31	380.1	34.810	34.89	0.080
11809	1.59	0.92	0.31	380.2	34.807	34.90	0.093
11810	1.59	0.94	0.29	380.3	34.810	34.90	0.090
11811	1.61	0.93	0.26	379.6	34.810	34.89	0.080
11812	1.57	0.94	0.32	380.0	34.803	34.90	0.097
11813	1.57	0.94	0.31	380.3	34.807	34.90	0.093
11814	1.57	0.94	0.30	380.2	34.810	34.90	0.090
11815	1.57	0.91	0.27	380.4	34.810	34.90	0.090
Average (56 Rods) ^(a)	1.58	0.90	0.30	380.2	34.805	34.894	0.088
±1σ ^(b) (56 Rods) ^(a)	0.01	0.02	0.01	0.4	0.003	0.005	0.005
Average (60 Rods) ^(c)	1.58	0.90	0.30	380.2	34.805	34.894	0.089
±1σ ^(b) (60 Rods) ^(c)	0.01	0.02	0.02	0.4	0.003	0.005	0.005
Average (64 Rods)	1.58	0.90	0.30	380.2	34.805	34.894	0.089
±1σ ^(b) (64 Rods)	0.01	0.02	0.02	0.4	0.003	0.005	0.005

(a) Fifty-six elements are in the initial core critical. Excluded elements include 11800, -801, -802, -803, -812, -813, -814, and -815.

(b) The uncertainty in these values is 1σ of the average population and not the average mean.

(c) Sixty elements are in the fully loaded core critical. Excluded elements include -812, -813, -814, and -815.

APPENDIX E: CORE LOADING AND APPROACH TO CRITICAL

Core fuel loading specifications were provided by General Atomics.^a The core loading arrangement was prepared using a detailed analysis of the as-built fuel data to optimize core excess reactivity.

Positions in the grid are identified with a letter-number pair. For example, the location of the in-core irradiation assembly is identified as C-4. The location of a specific position within an assembly is further designated by its location with respect to the center of the assembly. The location of the in-core irradiation position is identified as C-4 SW.

The initial core loading with nine fuel elements surrounding the control rods prior to the approach to critical is shown in Figure E.1. Figure E.2 shows the location of the two startup detectors used during fuel loading and the initial critical measurements and the position of two of the control rods (Shim 2 and Reg) without the initial fuel elements with the third control rod (Shim 1) fuel element cluster placed in position without a control rod. The core configuration with fuel cluster (FC) loading positions for the initial core critical and the operational core critical are shown in Figures E.3 and E.4, respectively. Figure 1.1 shows a photograph of the completed NRAD reactor core. Table E.1 contains the fuel element identifications for each position, which correspond with the as-built fuel data provided in Tables D.1 and D.2.

Count rates and multiplication factor measurements taken during the course of fuel loading are shown in Table E.2 and Figure E.5. The NRAD reactor was estimated to achieve criticality with 53.57 fuel elements.

^a “Neutron Radiography Reactor Analysis and Support: Startup Plan for the NRAD Reactor, Final Report,” 911183 rev. 1, GA Project 39296, TRIGA Reactor Division of General Atomics (January 13, 2010). [This reference is not available for public release.]

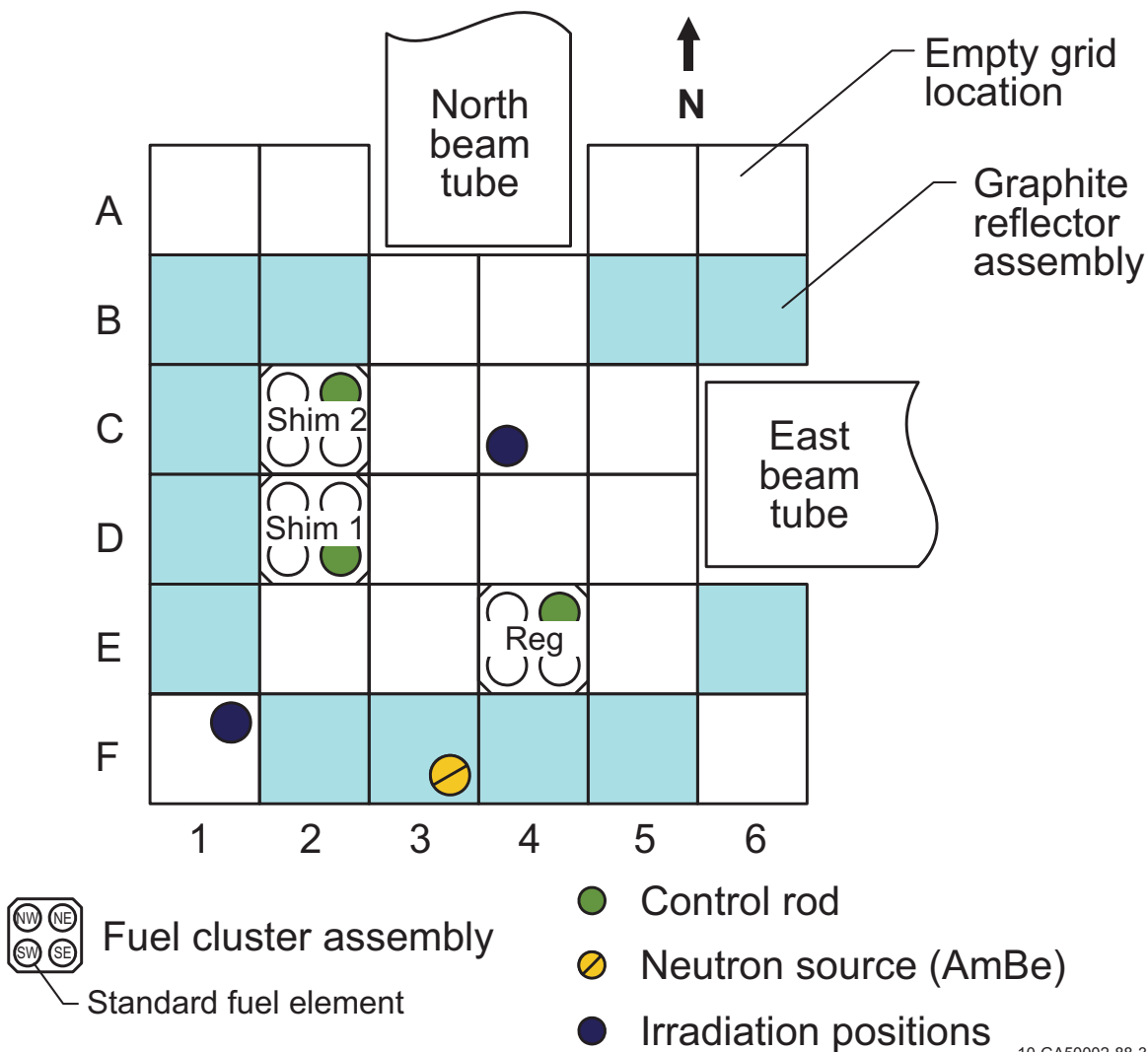

Figure E.1. Core Loading Prior to Startup (9 Fuel Elements).

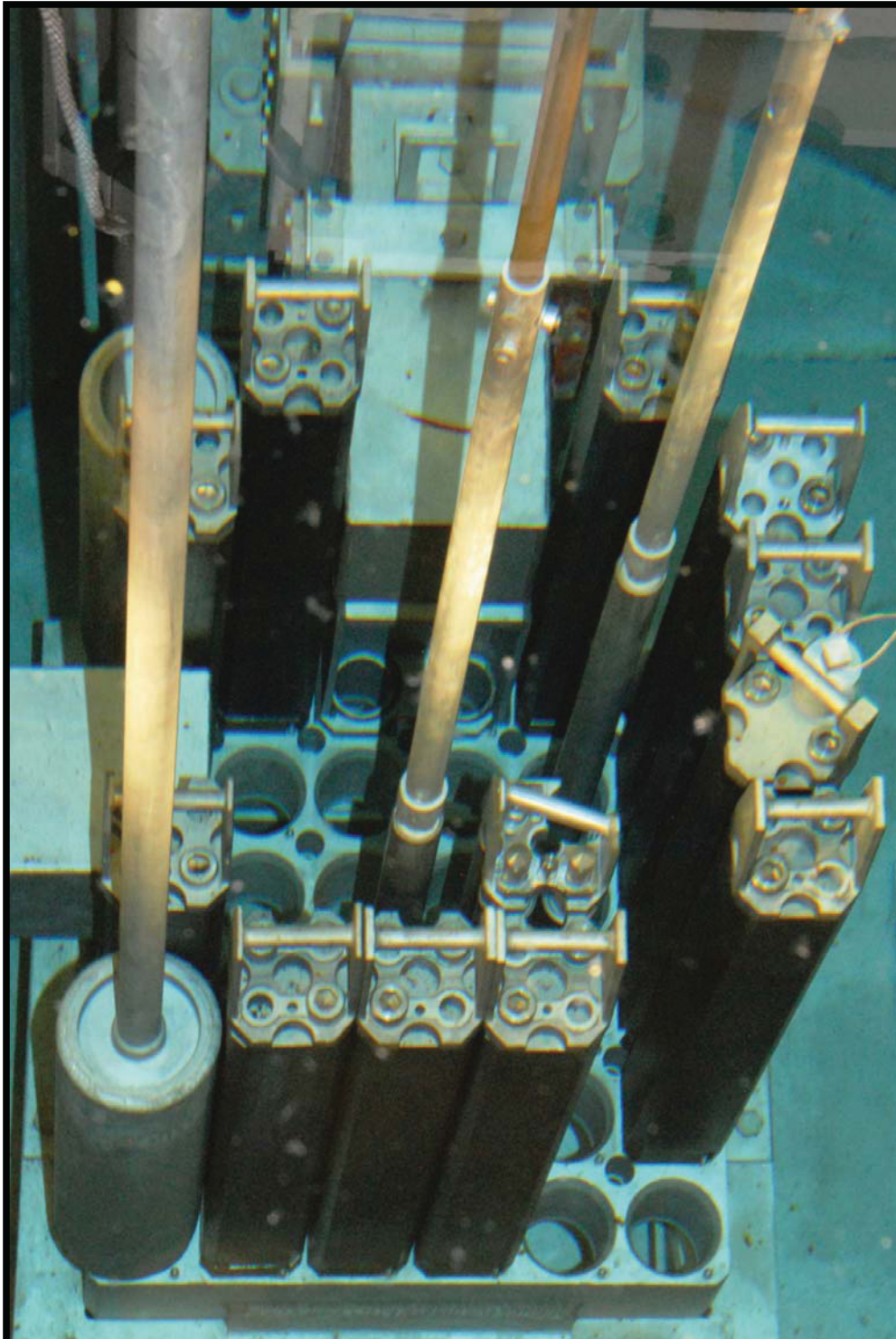
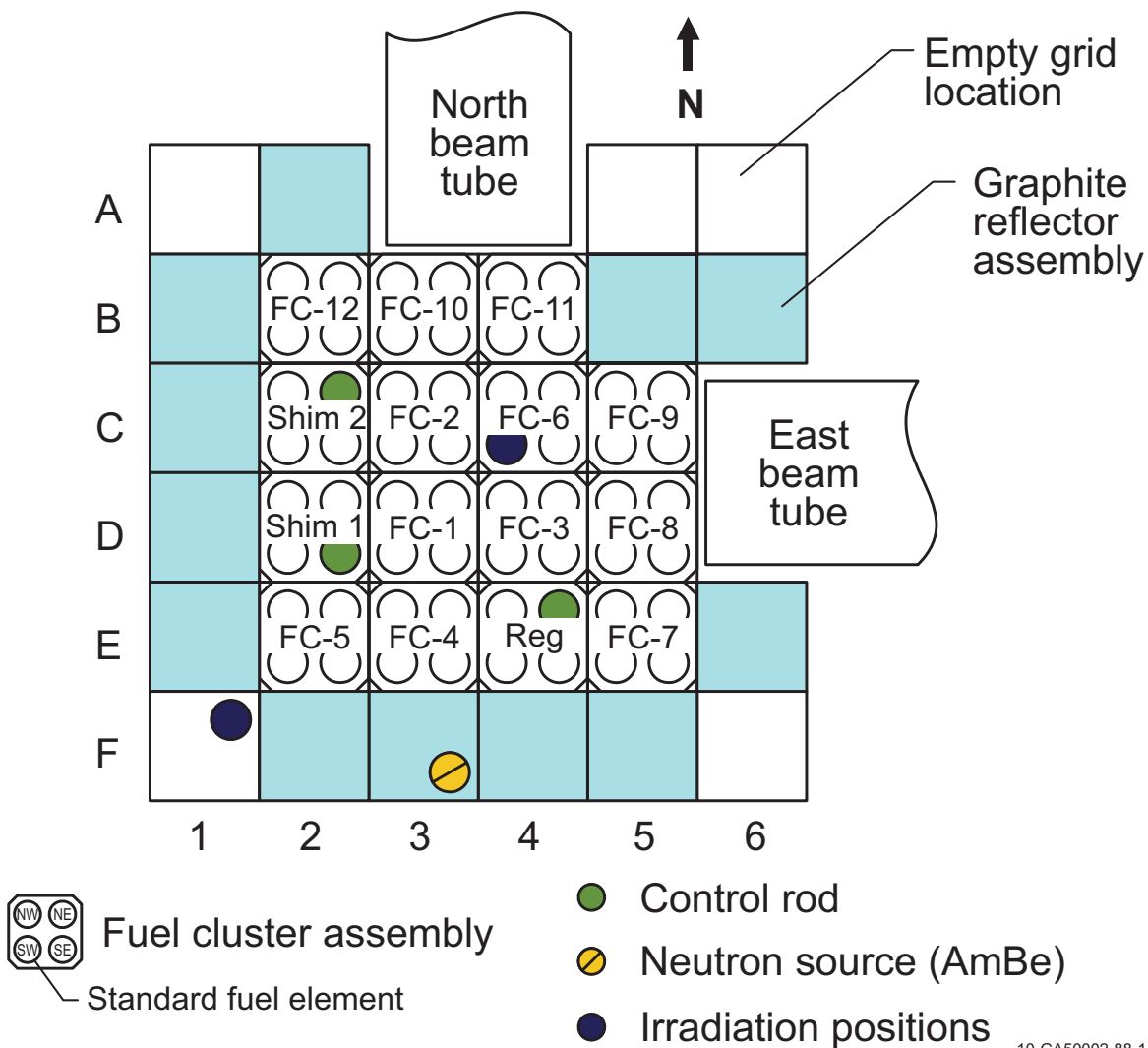
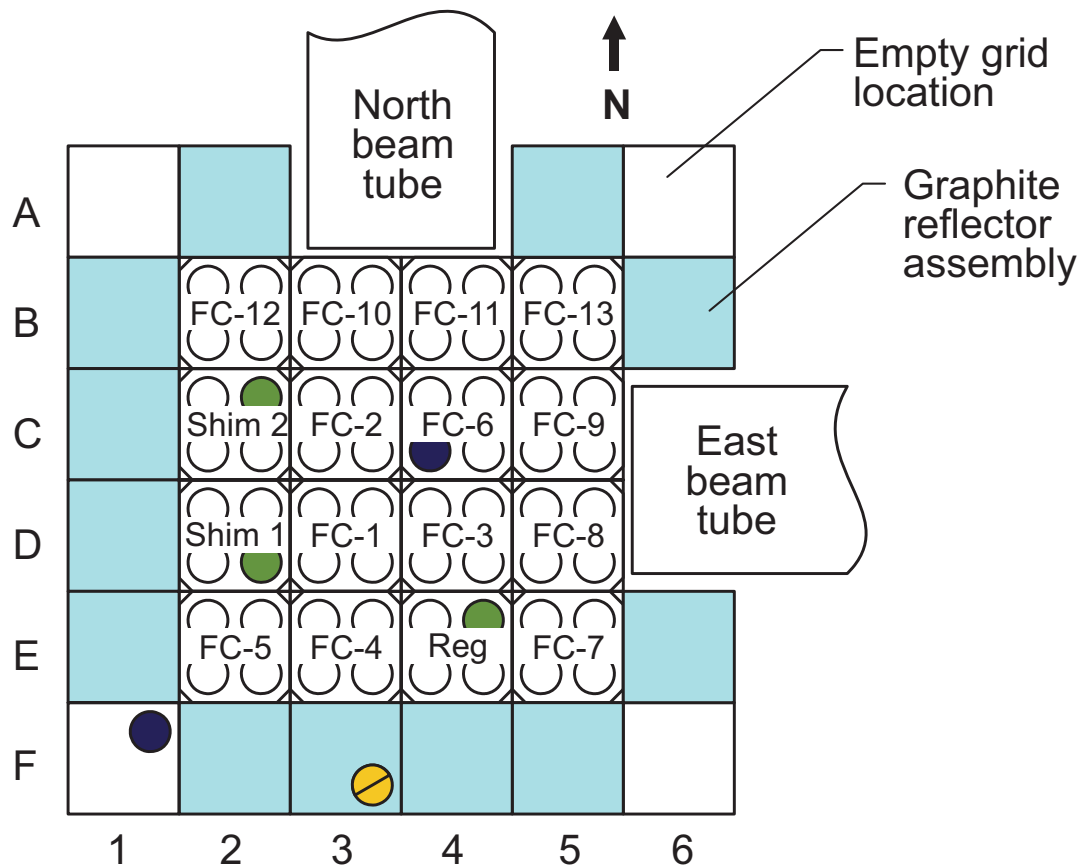

Figure E.2. Photograph of Core Loading Prior to Startup.



10-GA50002-88-1

Figure E.3. Initial Core Critical Configuration (56 Fuel Elements).



Fuel cluster assembly

Standard fuel element



Control rod



Neutron source (AmBe)



Irradiation positions

10-GA50002-88-2

Figure E.4. Fully Loaded Core Critical Configuration (60 Fuel Elements).

Table E.1. As-Built Fuel Positions in Core.

Cluster	Location	Element Number	Cluster	Location	Element Number	Cluster	Location	Element Number
Shim 1	D-2 NW	11755	FC-4	E-3 NW	11764	FC-10	B-3 NW	11776
	D-2 NE	11757		E-3 NE	11765		B-3 NE	11777
	D-2 SE	Shim 1		E-3 SE	11767		B-3 SE	11779
	D-2 SW	11756		E-3 SW	11766		B-3 SW	11778
Shim 2	C-2 NW	11752	FC-5	E-2 NW	11798	FC-11	B-4 NW	11785
	C-2 NE	Shim 2		E-2 NE	11796		B-4 NE	11787
	C-2 SE	11754		E-2 SE	11797		B-4 SE	11786
	C-2 SW	11753		E-2 SW	11799		B-4 SW	11784
Reg	E-4 NW	11758	FC-6	C-4 NW	11761	FC-12	B-2 NW	11810
	E-4 NE	Reg Rod		C-4 NE	11762		B-2 NE	11811
	E-4 SE	11760		C-4 SE	11763		B-2 SE	11808
	E-4 SW	11759		C-4 SW	Irradiation Position		B-2 SW	11809
FC-1	D-3 NW	11772	FC-7	E-5 NW	11804	FC-13 ^(a)	B-5 NW	11800
	D-3 NE	11773		E-5 NE	11806		B-5 NE	11802
	D-3 SE	11775		E-5 SE	11807		B-5 SE	11803
	D-3 SW	11774		E-5 SW	11805		B-5 SW	11801
FC-2	C-3 NW	11781	FC-8	D-5 NW	11790			
	C-3 NE	11782		D-5 NE	11788			
	C-3 SE	11783		D-5 SE	11791			
	C-3 SW	11780		D-5 SW	11789			
FC-3	D-4 NW	11768	FC-9	C-5 NW	11795			
	D-4 NE	11769		C-5 NE	11792			
	D-4 SE	11771		C-5 SE	11793			
	D-4 SW	11770		C-5 SW	11794			

(a) This fuel cluster is only in the fully loaded core configuration (60 fuel elements) and not the initial critical configuration using only 56 fuel elements.

Table E.2. NRAD LEU Core Approach to Critical.

# of Elements	Channel #1			Channel #2		
	CR (cpm)	1/M	k	CR (cpm)	1/M	k
9	221	1.000	0.000	72	1.000	0.000
21	715	0.309	0.691	204	0.353	0.647
25	1276	0.173	0.827	342	0.211	0.789
29	2220	0.100	0.900	511	0.141	0.859
32	2787	0.079	0.921	928	0.078	0.922
36	3673	0.060	0.940	1430	0.050	0.950
40	4875	0.045	0.955	2488	0.029	0.971
44	6140	0.036	0.964	4634	0.016	0.984
48	13305	0.017	0.983	7406	0.010	0.990
52	37642	0.006	0.994	24526	0.003	0.997

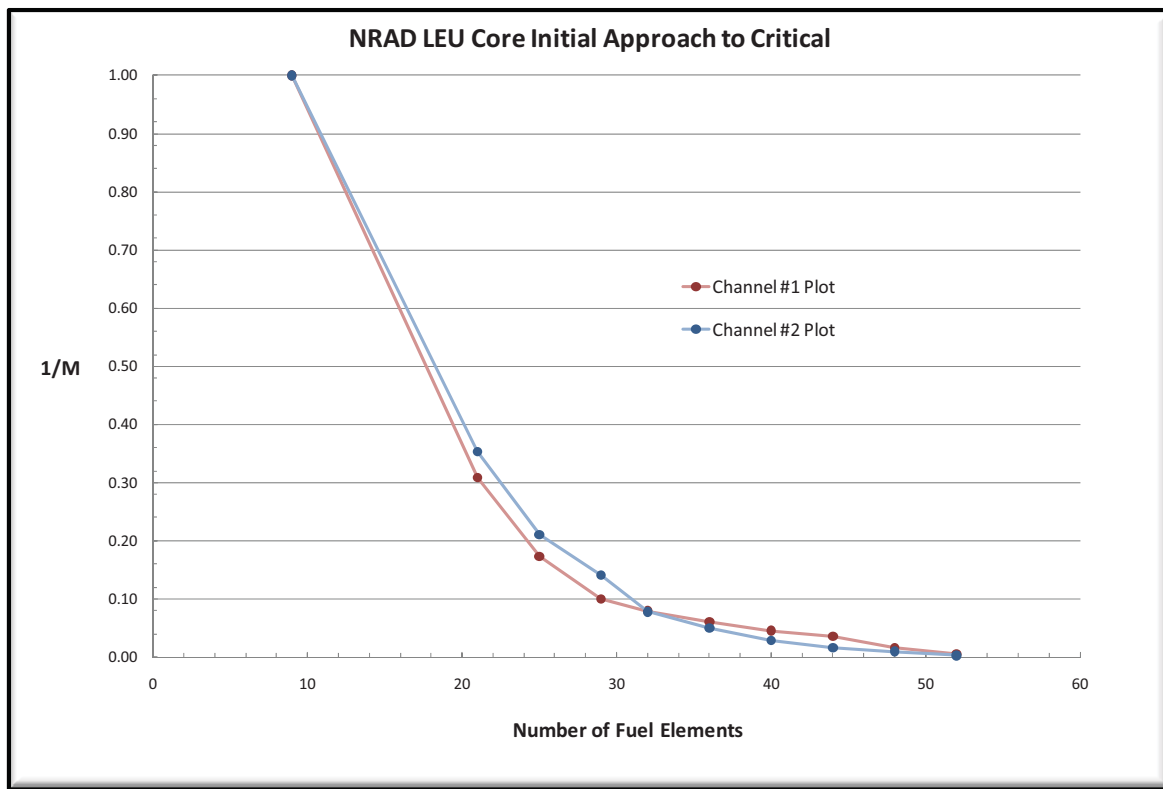

Figure E.5. NRAD LEU Core Approach to Critical.

APPENDIX F: NRAD AND TRIGA FUEL DESIGN DRAWINGS

This appendix contains a list of the drawings utilized to develop a detailed model of the NRAD reactor, evaluate uncertainties in the experimental measurements, and then develop a simplified benchmark model. These drawings are not available for public release.

- DWG-734030 rev. 2 (W0170-0108-DE) – Aperture Mechanism Final Design Layout
- DWG-734032 rev. 2 (W0170-0110-DD) – 4 Rod Fuel Cluster Assembly
- DWG-734033 (W0170-0111-DD) – Fuel Rod Assembly
- DWG-734034 rev. 2 (W0170-0112-DD) – Locking Plate for 4 Rod Fuel Cluster Assembly
- DWG-734035 rev. 2 (W0170-0113-DD) – Locking Bolt for 4 Rod Fuel Cluster Assembly
- DWG-734401 rev. 0 (W0170-0195-EE) – NRAD Cluster Fitting Layout
- DWG-734402 rev. 2 (W0170-0196-ED) – NRAD Cluster Fitting for NRAD Assembly
- DWG-735784 rev. 5 (W0170-0845-ED) – Top Handle for 4 Rod Fuel Cluster Assembly
- DWG-735785 rev. 4 (W0170-0846-ED) – Top Handle C2, C4 for 3 Element Top Handle Assembly
- DWG-735786 rev. 5 (W0170-0847-ED) – Top Handle D2, D4 for 3 Element Top Handle Assembly
- DWG-735877 rev. 2 (W0170-0849-EC) – C2, C4 3 Element Locking Plate
- DWG-735789 rev. 2 (W0170-0850-EC) – D2, D4 3 Element Locking Plate
- DWG-735790 rev. 2 (W0170-0851-ED) – D2, D4 3 Element Top Handle Assembly
- DWG-735791 rev. 2 (W0170-0852-ED) – C2, C4 3 Element Top Handle Assembly
- DWG-760123 rev. 4 – Control Rod Guide Tube for 3 Rod Fuel Cluster Assembly
- T0S210B212G – Reflector Fuel Element
- T0S210B213C – Fuel – 15” SST Fuel Element
- T0S210B217E – Rod – Fuel Element
- T0S210B229 – Disc
- T0S250B147C – Top Fitting – Control Rod
- T0S250B148C – Bottom Fitting – Control Rod
- T0S250B226C – Poison – Control Rod
- T4R250B136 – Spacer – Control Rod
- T4R250D135 – Control Rod
- T4S210C107 – Top Fitting – Fuel Rod
- T4S210C108 – Bottom Fitting – Fuel Rod
- T4S210D105 – Fuel Rod Assembly – 4 Rod Fuel Cluster
- W0170-0084-DE-00 – Graphite Element – Reactor Core, NRAD Layout
- W0170-0088-DD-00 – Graphite Element
- W0170-0089-DD-01 – Handle – Graphite Element Assembly
- W0170-0108-DE-02 – Aperture Mechanism Final Design Layout
- W0170-0115-DE-01 – Grid Plate, Core Support, and Instrumentation Thimble Final Design Layout
- W0170-0139-DE-01 – Grid Plate for NRAD Facility
- W0170-0141-DE-00 – Core Support for NRAD Facility
- W0170-0634-DE-00 – Control Rod Drive Installation Final Design Layout
- W0170-0635-DE-02 – Graphite Element with Source Assembly
- W0170-0636-DD-02 – Handle, Graphite Element Source Assembly
- W0170-0637-DD-00 – Graphite Element – Graphite Element Source Assembly
- W0170-0638-DD-01 – Source Tube
- W0170-0639-DC-01 – Source Tube Cap
- W0170-0687-DE-01 – Aperture Mechanism Assembly
- W0170-0688-DE-01 – Lower Beam Tube
- W0170-0689-DE-00 – Upper Beam Tube
- W0170-0694-DE-01 – East Beam Chamber Assembly
- W0170-0698-DD-00 – Support – Beam Chamber Support Assembly

- W0170-0726-DC-00 – Lower Tube Seal Plate for Aperture Mechanism Assembly
- W0170-0730-DD-01 – Aperture Block Guide
- W0170-0731-DE-00 – Aperture Block Assembly
- W0170-0732-DE-00 – Aperture Block Frame
- W0170-0733-DC-00 – Aperture Block
- W0170-0734-DC-00 – Aperture Block Front Cover
- W0170-0735-DA-00 – Aperture Block Adjusting Screw
- W0170-0742-DC-00 – Aperture Disc
- W0170-0770-DC-00 – Aperture Block Rear Cover
- W0170-0837-EE-00 – 3 Rod Fuel Cluster Assembly
- W0170-4351-EE-01 – North Beam Chamber Assembly
- W0170-4352-ED-01 – Aperture Block Assembly – NRS
- W0170-4353-ED-01 – Aperture Block Frame – NRS
- W0170-4354-EC-01 – Aperture Block – NRS
- W0170-4355-EC-00 – Aperture Block Front Cover – NRS
- W0170-4356-EC-00 – Aperture Block Rear Cover – NRS
- W0170-4644-EE-02 – NRAD Detector Housing Installation

APPENDIX G: EXAMPLE TRIGA FUEL MICROGRAPHS

The extra fuel element received by INL with the last NRAD reactor fuel shipment was examined with an electron microscope; example micrographs are shown in Figures G.1 through G.5. The microstructure of the fuel is comprised of two phases. The bright phase (white) is uranium enriched with a little zirconium (couple of wt.%). The dark matrix phase is zirconium enriched and contains hydrogen. This microstructure is very standard for this type of fuel and can be considered a “typical” microstructure.^a Figures G.4 and G.5 highlight the locations of zirconium and uranium, respectively, in the image shown in Figure G.3.

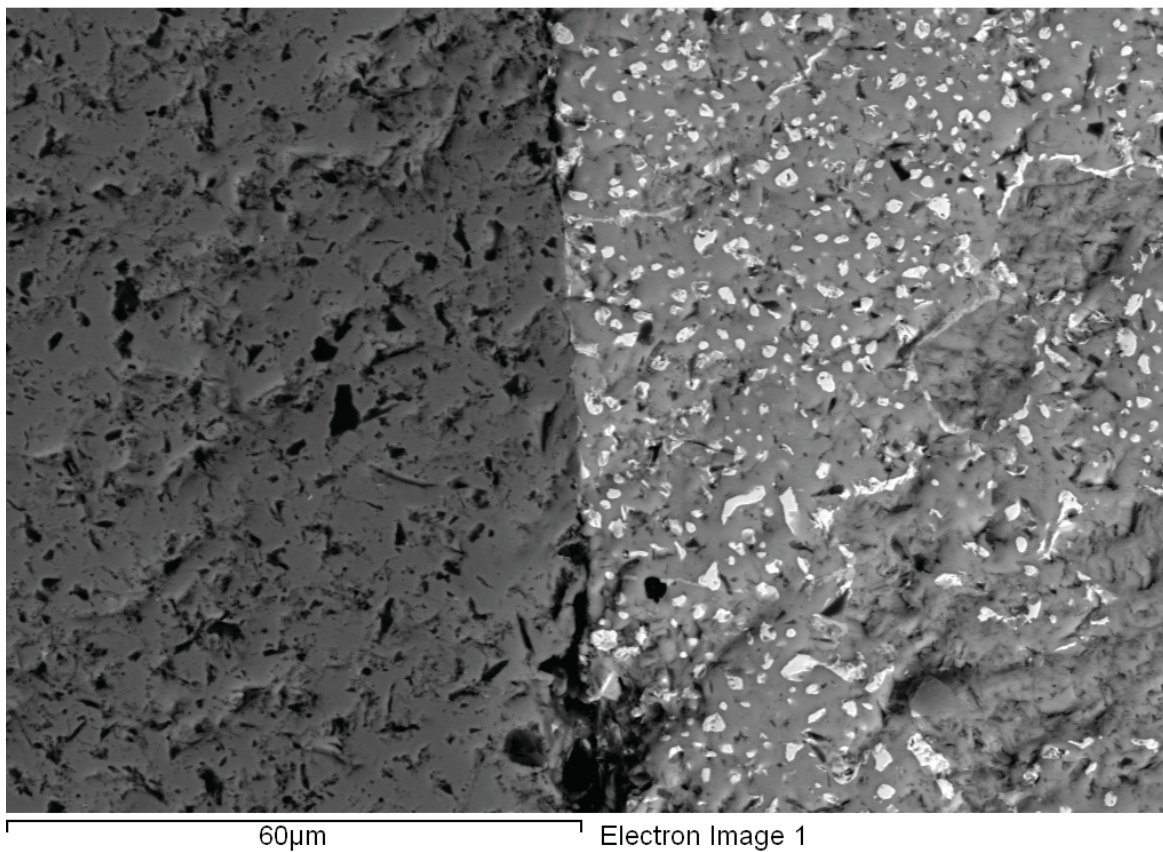

Figure G.1. Micrograph of U-Er-Zr-H Fuel.

^a Personal communication with Dennis D. Keiser at INL (September 7, 2010).

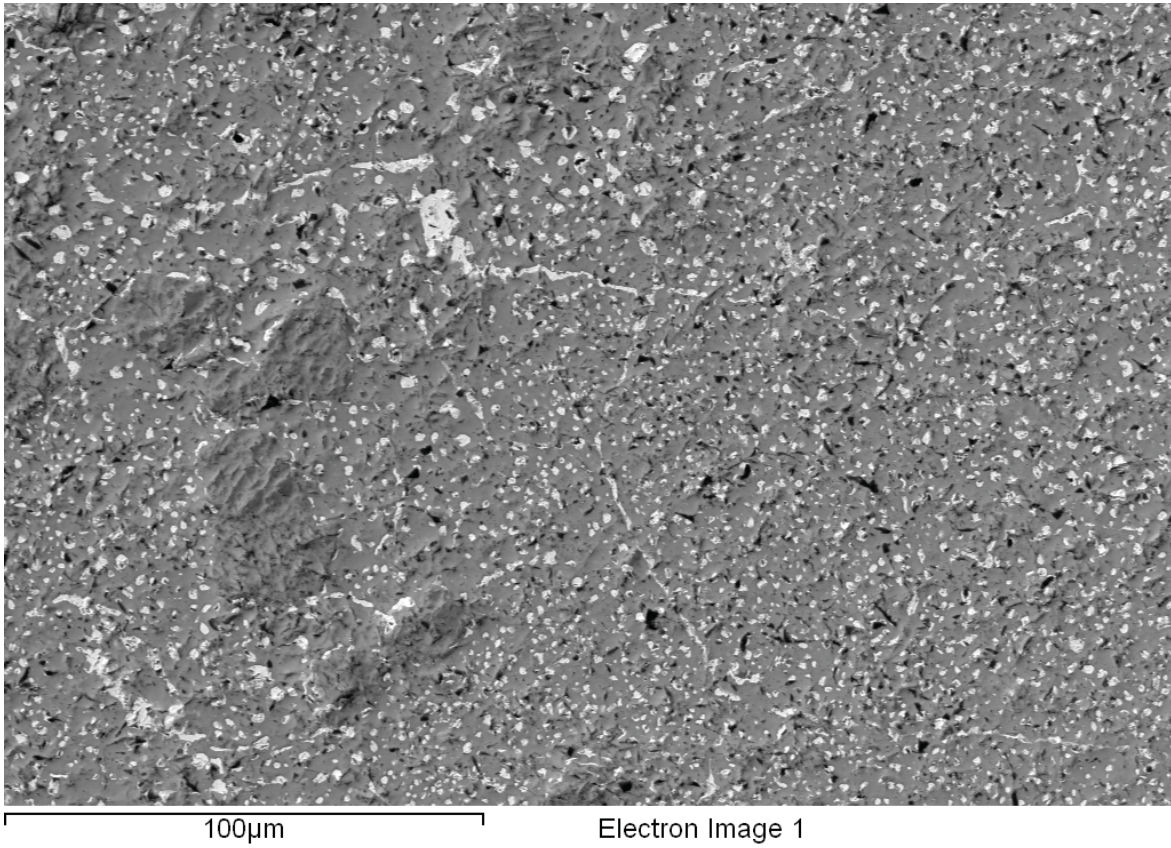

Figure G.2. Micrograph of U-Er-Zr-H Fuel.

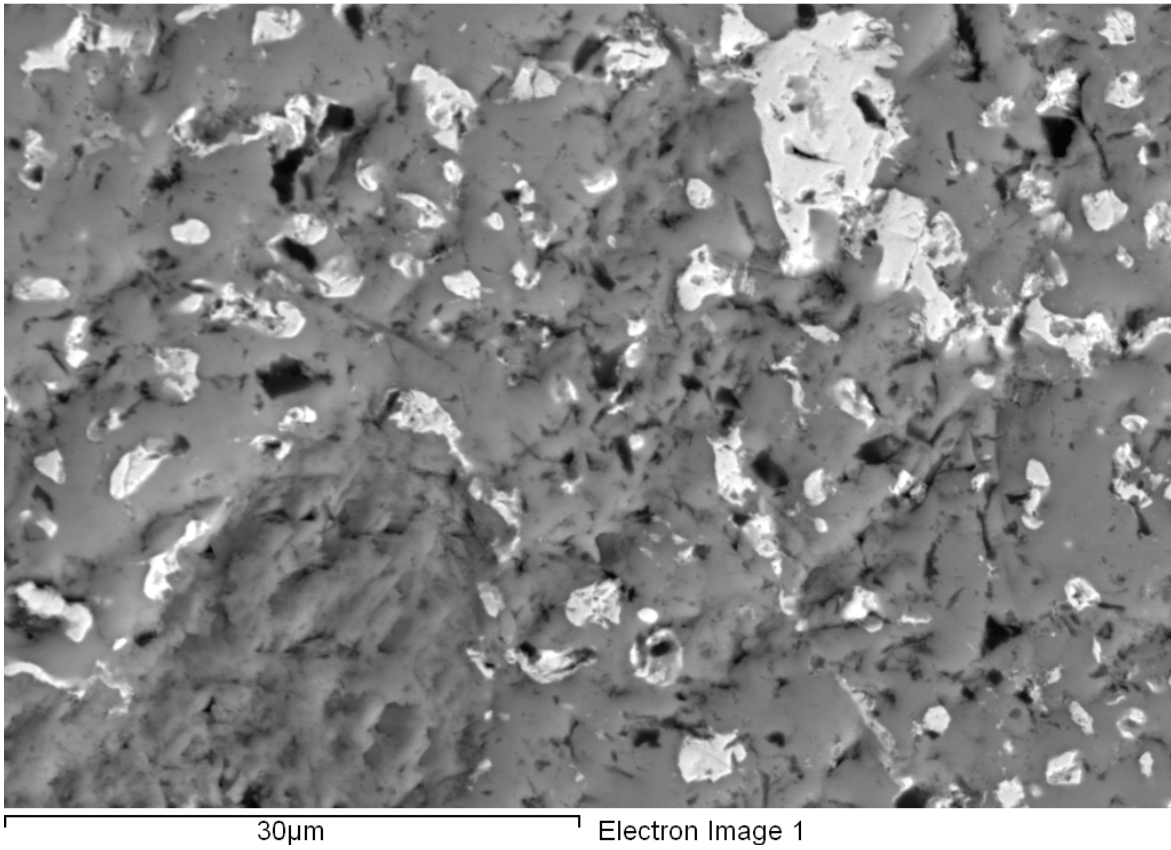

Figure G.3. Micrograph of U-Er-Zr-H Fuel.

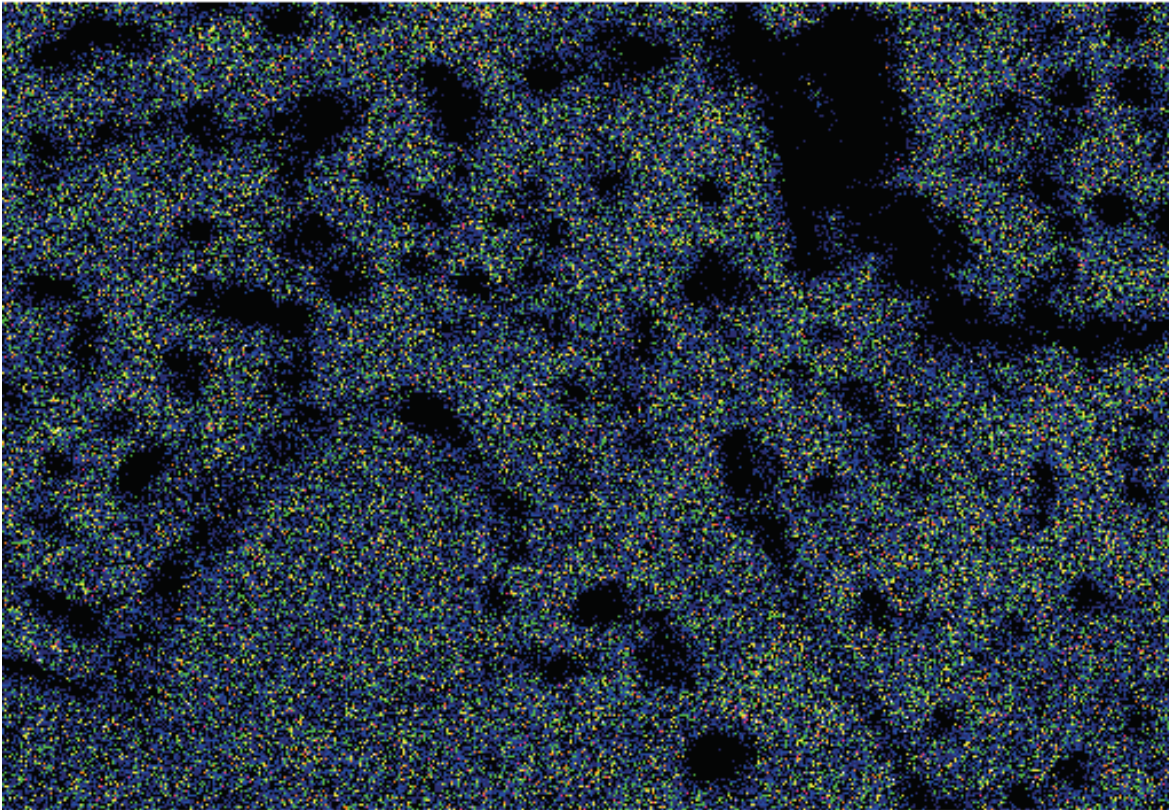

Figure G.4. Micrograph of U-Er-Zr-H Fuel showing Location of Zirconium in Figure G.3.

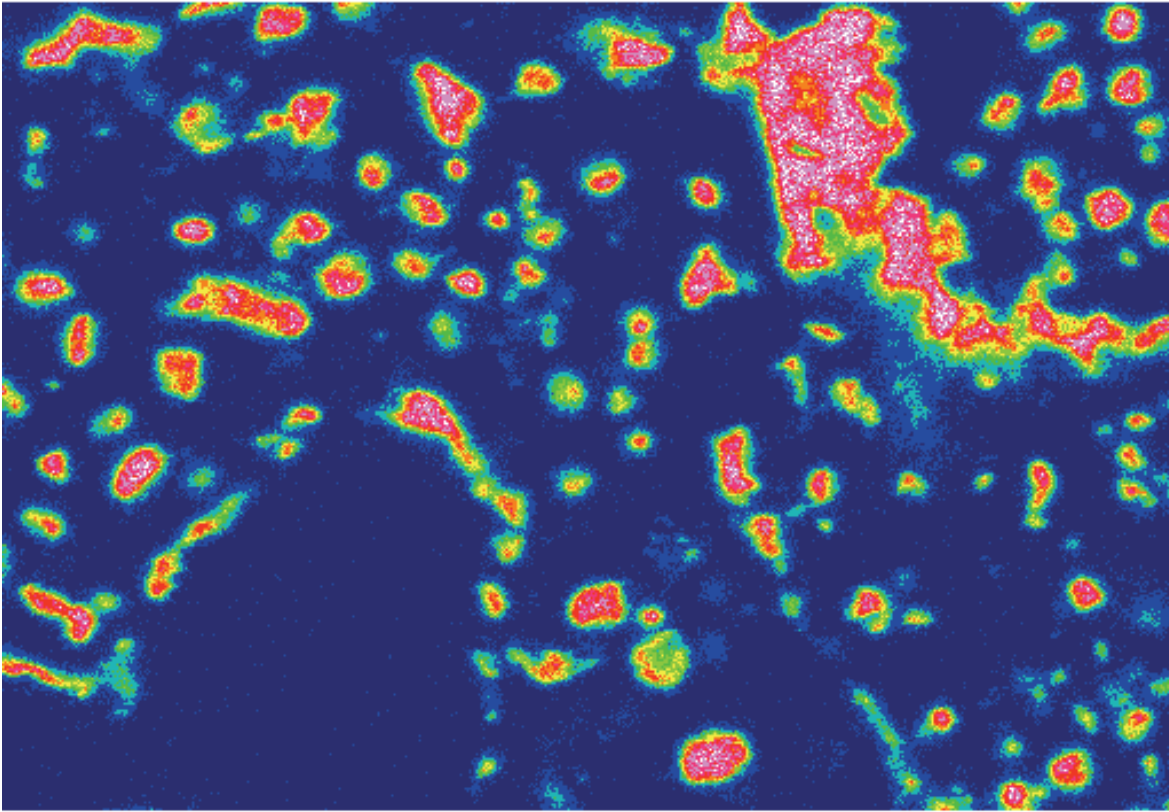

Figure G.5. Micrograph of U-Er-Zr-H Fuel showing Location of Uranium in Figure G.3.

APPENDIX H: ADDITIONAL MEASUREMENTS PROVIDED BY CERCA

H.1 Uranium Measurements

Five batches of uranium fuel were sampled by CERCA and provided to Anthony Veca of TRIGA International from Laurent Hallé of AREVA-CERCA on May 12, 2010.^a Discussion of the measurement dates and method were not available. A summary of what information was provided is found in Table H.1.

^a Personal communication with John M. Bolin at General Atomics (April 11, 2011).

Table H.1. Analysis of Five Uranium Batches.

Eléments	Limites Spécification G 160 Rev 6	Mesures				
		Lot P30 230	Lot 130 A	Lot 131 A	Lot 133 A	Lot 134 A
U 234	≤ 1,5 %	0,16	0,2	0,2	0,2	0,2
U 235	19,55 % ≤ X ≤ 19,95 %	19,86	19,73	19,79	19,84	19,84
U 236	≤ 4 %	0,099	0,3	0,29	0,27	0,3
Ag	à mesurer	1	10	10	10	5
B	≤ 1 ppm	0,5	0,3	0,3	0,3	0,31
C	≤ 800 ppm	254	228	277	238	176
Cd	≤ 1 ppm	0,3	0,2	0,2	0,2	0,2
Co	à mesurer	1	3	3	3	3
Cr	à mesurer	6,5	30	30	30	30
Cu	à mesurer	5,6	13,6	19,5	13,6	10
Fe	à mesurer	67	83	68	50	101
Li	≤ 10 ppm	1	1	1	1	1
Ni	à mesurer	28	31	31	34	30,7
Si	≤ 300 ppm	26	25	29	29	29
Sn	≤ 100 ppm	1	5	5	5	5
Zr	≤ 250 ppm	9,7	100	100	100	100
Autres						
Total Equ. Bore Groupe A		1,0431	0,9487	0,9445	0,9308	0,9261
Al	≤ 150 ppm	10	59	75	50	50
Ca	≤ 100 ppm	5	50	50	50	50
Mg	à mesurer	1	6	6	6	6
N	à mesurer	1	131	128	128	128
Mn	à mesurer	11	11	9	9	9
Mo	à mesurer	2,3	18	18	18	18
V	à mesurer	1	2	2	2	2
P	à mesurer	20	17	23	23	23
Pb	à mesurer	1	4	4	4	4
W	≤ 100 ppm	2,6	14	14	14	14
Total	≤ 1500 ppm	546,5	842,1	903	818,1	795,21
Element Groupe B si dépassement		0	0	0	0	0
Total Groupe A + Groupe B	≤ 2,5 ppm	1,0431	0,9487	0,9445	0,9308	0,9261

H.2 Zirconium Measurement

An impurity analysis was performed by CERCA on an “R sponge”, which is zirconium material used in the manufacture of the fuel elements and zirconium rod. The measurement results were also provided to Anthony Veca of TRIGA International from Laurent Hallé of AREVA-CERCA on May 12, 2010.^a Discussion of the measurement dates and method were not available. A summary of what information was provided is found in Table H.2.

Table H.2. Impurity Analysis of R Sponge.

Analyses sur Lingotin / PV N° 20080036		
Eléments	Résultats d'analyses en ppm	Spécification G 530 Rev. 0
Al	24	75
B	<0,5	0,5
C	<15	250
Cd	<0,5	0,5
Co	<10	20
Cr	45	200
Cu	<20	30
Fe	277	*
Hf	46	100
Mn	11	50
Mo	<20	50
N	11	50
Ni	<10	70
O	525	1400
Si	<30	120
Ti	<10	50
U	<1,5	3
W	<20	50
Fe+Cr+Ni	332	600

^a Personal communication with John M. Bolin at General Atomics (April 11, 2011).

APPENDIX I: CALCULATION OF DELAYED NEUTRON FRACTION, β_{eff}

Reactivity worths for NRAD measurements are typically reported in \$ or ρ . Staff historically use a β_{eff} value of 0.0071 to convert reactivity measurements to and from Δk . General Atomics utilizes a β_{eff} value of 0.0078 in their design analysis of the NRAD reactor.^a Reported values for the delayed neutron fraction in TRIGA-type reactors have been known to range between 0.0070 and 0.0080.^{b,c,d,e} The delayed neutron fraction is typically insensitive to reflector material.^c

Delayed neutron calculations were performed to compute the value of β_{eff} for the NRAD reactor cores using the prompt method:^f

$$\beta_{\text{eff}} = 1 - \frac{k_{\text{prompt}}}{k_{\text{eff}}}$$

Delayed neutron calculations were also performed using the adjoint-weighted point kinetics capabilities included in MCNP5-1.60.^g Previous studies have indicated that calculated values for β_{eff} depend strongly on which nuclear data library is utilized in the analysis. This is not due to the cross section data; the primary difference is in the delayed nuclear data. It is interesting to note that only the delayed neutron fraction for the thermal fission in ²³⁵U in the ENDF/B-VII.0 data library matches the original measured value of 0.00650.^h It was also determined that β_{eff} strongly depends on the core size and less on the fuel type.^d

Calculations of β_{eff} were performed using ENDF/B-VII.0, -VI.8, JEFF-3.1, and JENDL-3.3 neutron cross section data libraries using the benchmark models for the critical configurations (Section 3.1). Calculations using ENDF/B-VII.0 and the detailed models in Appendix C were also performed. Results are summarized in Table I.1. The average value using either the prompt method or the adjoint-weighted point kinetics calculations are provided, as well as an overall average value computed from the ten values computed for each core configuration. Because of the large spread in reported and calculated β_{eff} values, a median value of 0.0075 is selected with an uncertainty of $\pm 5\%$ ($\pm 0.000375 \Delta\beta_{\text{eff}}$) for all reactivity measurements in both core configurations.

^a "LEU Upgrade of the NRAD Reactor, Final Report," 911193 rev. 0, GA Project 39296, TRIGA Reactor Division of General Atomics (August 27, 2010). [This reference is not available for public release.]

^b A. Trkov, M. Ravnik, H. Boeck, and B. Glumac, "Reactivity Measurements in a Close-to-Critical TRIGA Reactor Using a Digital Reactivity Meter," *Kerntechnik*, **57**, 296-300 (1992).

^c M. T. Simnad, F. C. Foushee, and G. B. West, "Fuel Elements for Pulsed TRIGA[®] Research Reactors," *Nucl. Technol.*, **28**, 31-56 (1976).

^d L. Snoj, A. Kavčič, G. Žerovnik, and M. Ravnik, "Calculation of Kinetic Parameters for Mixed TRIGA Cores with Monte Carlo," *Ann. Nucl. Energy*, **37**, 223-229 (2010).

^e T. Matsumoto, "Benchmark Analysis of Criticality Experiments in the TRIGA Mark II Using a Continuous Energy Monte Carlo Code MCNP," *J. Nucl. Sci. Technol.*, **35**, 662-670 (1998).

^f R. K. Meulekamp and S. C. van der Marck, "Calculating the Effective Delayed Neutron Fraction with Monte Carlo," *Nucl. Sci. Eng.*, **152**, 142-148 (2006).

^g B. C. Kiedrowski, T. E. Booth, F. B. Brown, J. S. Bull, J. A. Favorite, R. A. Forster, and R. L. Martz, "MCNP5-1.60 Feature Enhancements & Manual Clarifications," LA-UR-10-06217, Los Alamos National Laboratory (2010).

^h G. R. Keepin, T. F. Wimett, and R. K. Zielger, "Delayed Neutrons from Fissionable Isotopes of Uranium, Plutonium, and Thorium." *Physical Review*, **107**, 1044 (1957).

Table I.1. Calculated Delayed Neutron Fractions for the NRAD Core.

Model (Library)	56-Fuel-Element Core		60-Fuel-Element Core	
	Prompt Method ($\pm 1\sigma$)	Adjoint- Weighted Calculation ($\pm 1\sigma$)	Prompt Method ($\pm 1\sigma$)	Adjoint- Weighted Calculation ($\pm 1\sigma$)
Detailed (ENDF/B-VII.0)	0.00717 (± 0.00010)	0.00738 (± 0.00011)	0.00732 (± 0.00010)	0.00764 (± 0.00011)
Benchmark (ENDF/B-VII.0)	0.00740 (± 0.00010)	0.00738 (± 0.00011)	0.00754 (± 0.00010)	0.00732 (± 0.00011)
Benchmark (ENDF/B-VI.8)	0.00799 (± 0.00010)	0.00778 (± 0.00011)	0.00754 (± 0.00010)	0.00773 (± 0.00011)
Benchmark (JEFF-3.1)	0.00774 (± 0.00010)	0.00763 (± 0.00011)	0.00751 (± 0.00010)	0.00759 (± 0.00011)
Benchmark (JENDL-3.3)	0.00770 (± 0.00010)	0.00732 (± 0.00011)	0.00739 (± 0.00010)	0.00739 (± 0.00011)
Method Average	0.00760 (± 0.00032)	0.00750 (± 0.00020)	0.00746 (± 0.00010)	0.00753 (± 0.00017)
Core Average	0.00755 (± 0.00026)		0.00750 (± 0.00014)	
Selected Value	0.00750 (± 0.000375)		0.00750 (± 0.000375)	